

# ICSE 2025 EXAMINATION

## Sample Question Paper - 1

### Physics

Time: 2 hours.

Total Marks: 80

---

#### General Instructions:

1. Answers to this paper must be written on the paper provided separately.
  2. You will **not** be allowed to write during the first **15** minutes.  
*This time is to be spent in reading the question paper.*
  3. The time given at the head of the paper is the time allotted for writing the answers.
  4. **Section A** is compulsory. Attempt **any four** questions from **Section B**.
  5. The intended marks of questions or parts of questions are given in brackets [ ].
- 

#### SECTION A (40 Marks)

Attempt *all* Questions from this Section

#### Question 1

- (i) A simple pendulum is taken from earth to an altitude. Its time period will
- a) Remain unchanged
  - b) increase
  - c) decrease
  - d) Becomes infinite
- (ii) The mass of the earth is  $5.97 \times 10^{24}$  kg. Its order of magnitude will be
- a) 25
  - b)  $10^{24}$
  - c) 24
  - d)  $10^{25}$
- (iii) The SI unit for velocity is
- a) km/h
  - b) m/s
  - c) cm/min
  - d) none of the above
- (iv) The area enclosed by velocity-time graph and the time axis will be equal to the magnitude of
- a) Retardation
  - b) Displacement
  - c) Acceleration
  - d) Speed

(v) **Assertion:** The unit of speed can be expressed in terms of unit of length and time.

**Reason:** Speed is considered as one of the basic or fundamental units.

- a) Both A and R are true and R is the correct explanation of A
- b) Both A and R are true and R is not the correct explanation of A
- c) Assertion is false but reason is true.
- d) Assertion is true reason is false.

(vi) A child on a cart with wheels throws a sandbag forward. As a result:

- a) He moves forward
- b) He moves to the right
- c) He moves to the left
- d) He moves backward

(vii) Identify the contact force among the following.

- a) Electric force
- b) Magnetic force
- c) Tension force applied through string
- d) Gravitational force

(viii) When a fireman directs a powerful stream of water on a fire from a hosepipe, the hosepipe tends to go backward. This is due to:

- a) Newton's 3rd law
- b) Law of conservation of charges
- c) Law of conservation of energy
- d) Law of Inertia

(ix) The normal atmospheric pressure is

- a) 76 m of Hg
- b) 76 cm of Hg
- c) 76 Pascal
- d) 76 mm of Hg

(x) Why does the body of a deep-sea fish burst on bringing her above the sea level?

- a) The atmospheric pressure above the sea level is higher than inside the sea.
- b) The atmospheric pressure above the sea level is lower than inside the sea.
- c) The body of fish contains dissolved oxygen at much higher pressure than the atmospheric pressure.
- d) The body of fish contains dissolved oxygen at much lower pressure than the atmospheric pressure.

(xi) What will be the weight of a body on the Moon if it weighs 48 N on the Earth?

- a) 48 N
- b) 8 N
- c) 9.8 N
- d) 98 N

- (xii) A combination of wood and iron, just floats in the water at room temperature. Explain what you will observe when the water is heated.
- The combination will still float with the same position.
  - The combination will float on the surface of the liquid.
  - The combination will sink
  - None of the above
- (xiii) When a solid body is fully immersed in a liquid, the volume of the displaced liquid is
- Less than the volume of the solid body.
  - Depends on the manner in which the body is being immersed in the liquid.
  - Greater than the volume of the solid body.
  - Equal to the volume of the solid body.
- (xiv) The increase in the concentration of carbon dioxide due to human activities is responsible for \_\_\_\_ increase in greenhouse effect.
- 60%
  - 10%
  - 35%
  - 5%
- (xv) According to the new cartesian sign convention,
- Focal length of both, convex and concave mirror is positive.
  - Focal length of the convex mirror is negative and that of the concave mirror is positive.
  - Focal length of both, convex and concave mirror is negative.
  - Focal length of the convex mirror is positive and the concave mirror is negative.

## Question 2

- (i)
- A hydraulic jack is based on \_\_\_\_\_ [Pascal's/Archimedes/Buoyancy] principle.
  - The error induced by wear and tear of screw of a screw gauge is called \_\_\_\_\_.
  - The focal length of a spherical mirror is \_\_\_\_\_ [equal to /half of/zero compared to] its radius of curvature.
  - A \_\_\_\_\_ is a special type of hydrometer to measure the purity of milk
  - The magnetic field lines of earth are \_\_\_\_\_ [normal/parallel/close] to earth's surface near the magnetic poles and \_\_\_\_\_ [normal/parallel/close] to earth's surface near the magnetic equator.
- (ii) A polythene piece is rubbed with wool as a result of which it acquires a negative charge. Will there be any exchange of mass between the wool and the polythene? [2]
- (iii) A stone is dropped from a top of tower 50 m high. How long will it take to fall to the foot of the cliff? [2]

### Question 3

(i) Observe the diagram (A) and (B) and answer the following questions based on them:

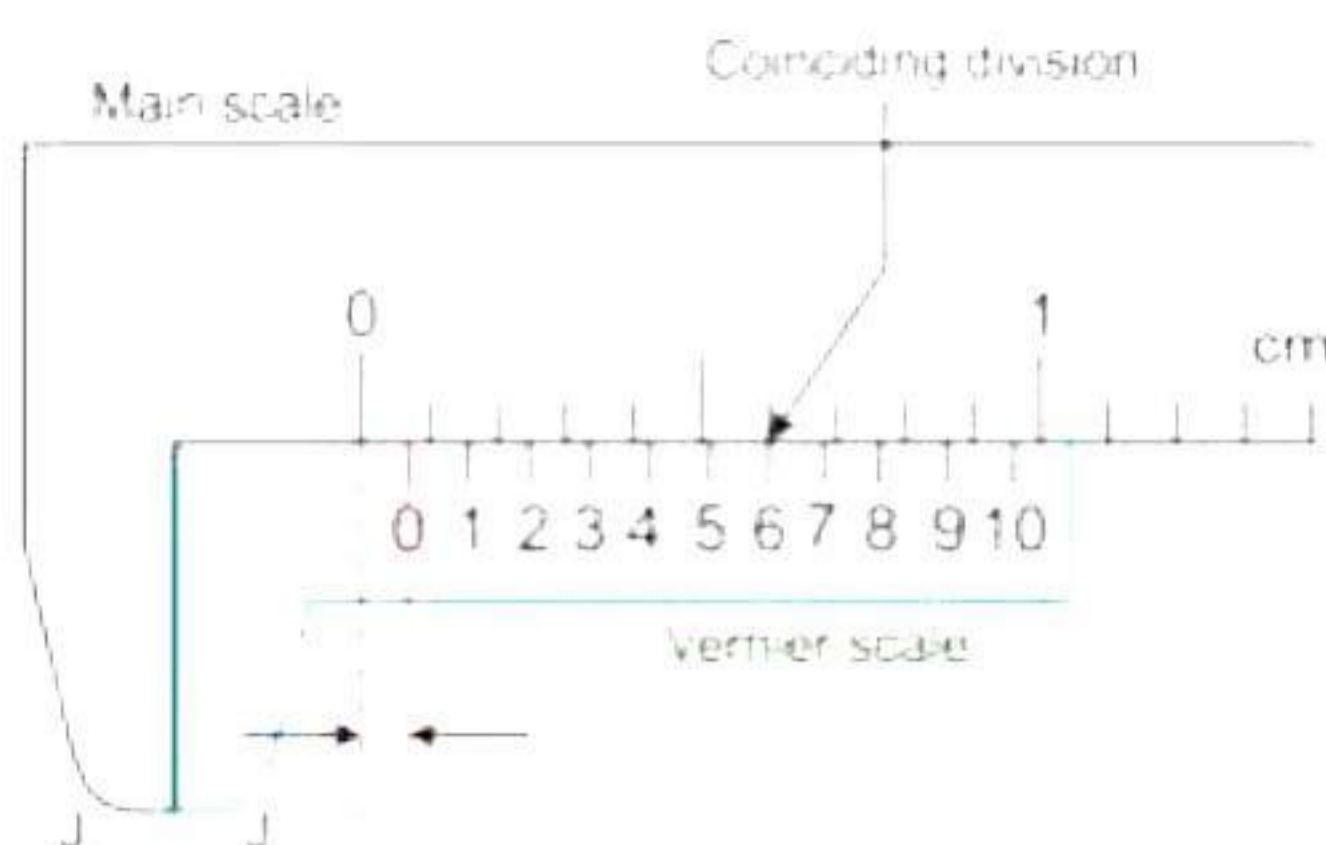

(A)

- What does the diagram (A) represent? Define it. [2]
- (ii) Two simple pendulums A and B have equal lengths but their bob masses are 75 g and 125 g respectively. What would be the ratio of their time periods? Give reason for your answer. [2]
- (iii) Name two substances which expand on heating. [2]
- (iv) Draw a velocity-time graph when the velocity remains constant. [2]
- (v) What is the source of tension in a string on an atomic scale? [2]
- (vi) A long metal rod is bent to form a ring with a small gap. If this is heated, will this gap increase or decrease? [2]
- (vii) Why do birds puff up their feathers in winter? [2]

## SECTION B (40 Marks)

Attempt *any four* Questions from this Section.

### Question 4

(i) Define pitch of a screw gauge.

The thimble of a screw gauge has 50 divisions for one revolution. The spindle advances 1 mm when the screw is turned through two revolutions. What is the least count of the screw gauge? When the screw gauge is used to measure the diameter of the wire, the reading on the sleeve is found to be 0.05 cm and the reading on the thimble is found to be 27 divisions. What is the diameter of the wire in CGS unit? [4]

(ii) Ram throws a stone in the pond. It displaced 1.5 kg of water. Calculate the buoyant force acting on the stone. ( $g = 9.8 \text{ m/s}^2$ ) [3]

(iii) A glass slab of dimensions  $10 \text{ cm} \times 10 \text{ cm} \times 4 \text{ cm}$  and weight 8 N rests with its sides  $10 \text{ cm} \times 10 \text{ cm}$  in contact with the top of the table. Calculate the pressure exerted. If the slab is tilted and allowed to rest on the surface on side  $10 \text{ cm} \times 4 \text{ cm}$ , will the pressure increase, decreases or remain the same? [3]

### Question 5

(i) A body covers a distance 's' in time 't' as follows:

|      |   |   |    |    |    |    |    |
|------|---|---|----|----|----|----|----|
| t(s) | 0 | 2 | 5  | 10 | 12 | 15 | 20 |
| s(m) | 0 | 4 | 10 | 10 | 8  | 5  | 0  |

Plot s-t graph. Determine the displacement of the body at time

(a) 7 s and (b) 13 s. [3]

(ii) A scooter initially at rest picks up a velocity of 20 m/s over a distance of 40 m. Calculate acceleration and time in which it attains the velocity of 20 m/s. [3]

(iii) The graph given below shows how three runners A, B and C ran a 200-metre race. [4]

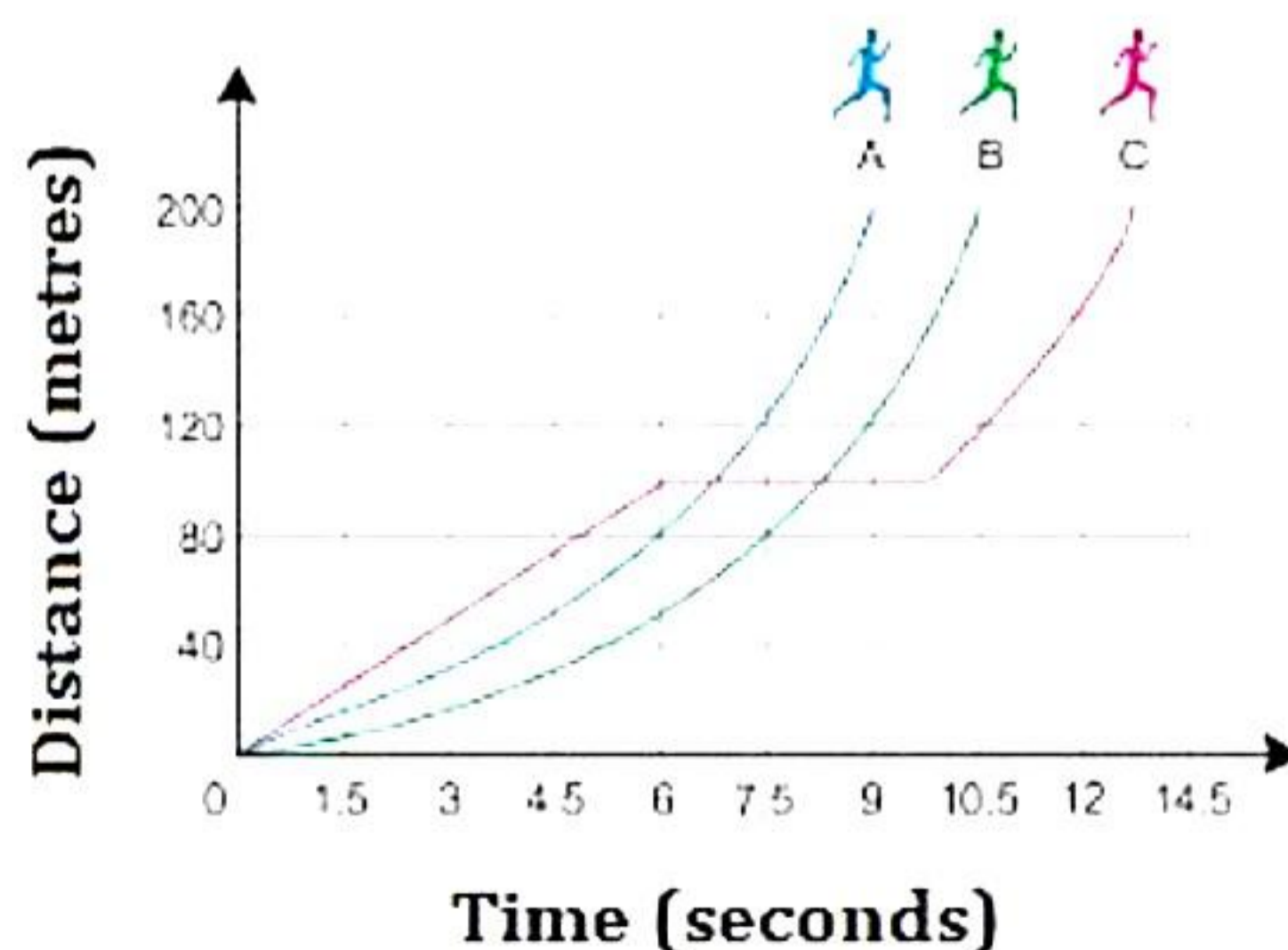

Answer the following questions:

(a) Which runner won the race?

(b) Which runner stopped for a rest and how long did he stop for?

(c) How long did the runner B take to complete the race?

(d) Calculate the runner A's average speed.

### Question 6

- (i) Two bodies P and Q are of the same mass but are moving with velocities of  $v$  and  $5v$  respectively. Compare their inertia and momentum. [4]
- (ii) Calculate hydrostatic pressure at a depth of 1500 cm in sea water of density  $1030 \text{ kg/m}^3$ . Take  $g = 10 \text{ m/s}^2$ . Express your answer in SI unit and also in bar. [3]
- (iii) Draw a diagram for a spring balance and explain how it is used to measure the weight of a body. [3]

### Question 7

- (i) What do you mean by a freezing mixture? Explain. [3]
- (ii) Mohit takes a thin can fitted with an airtight stopper. He removes the stopper of the can and boils small quantity of water in the can. Gradually the steam occupies the entire space of can by expelling the air from it as shown in Fig (a). He puts the stopper on the can tightly and then simultaneously removes the flame beneath the can. When he pours the cold water over the can he observes that the can collapses inwards as shown in fig (b).

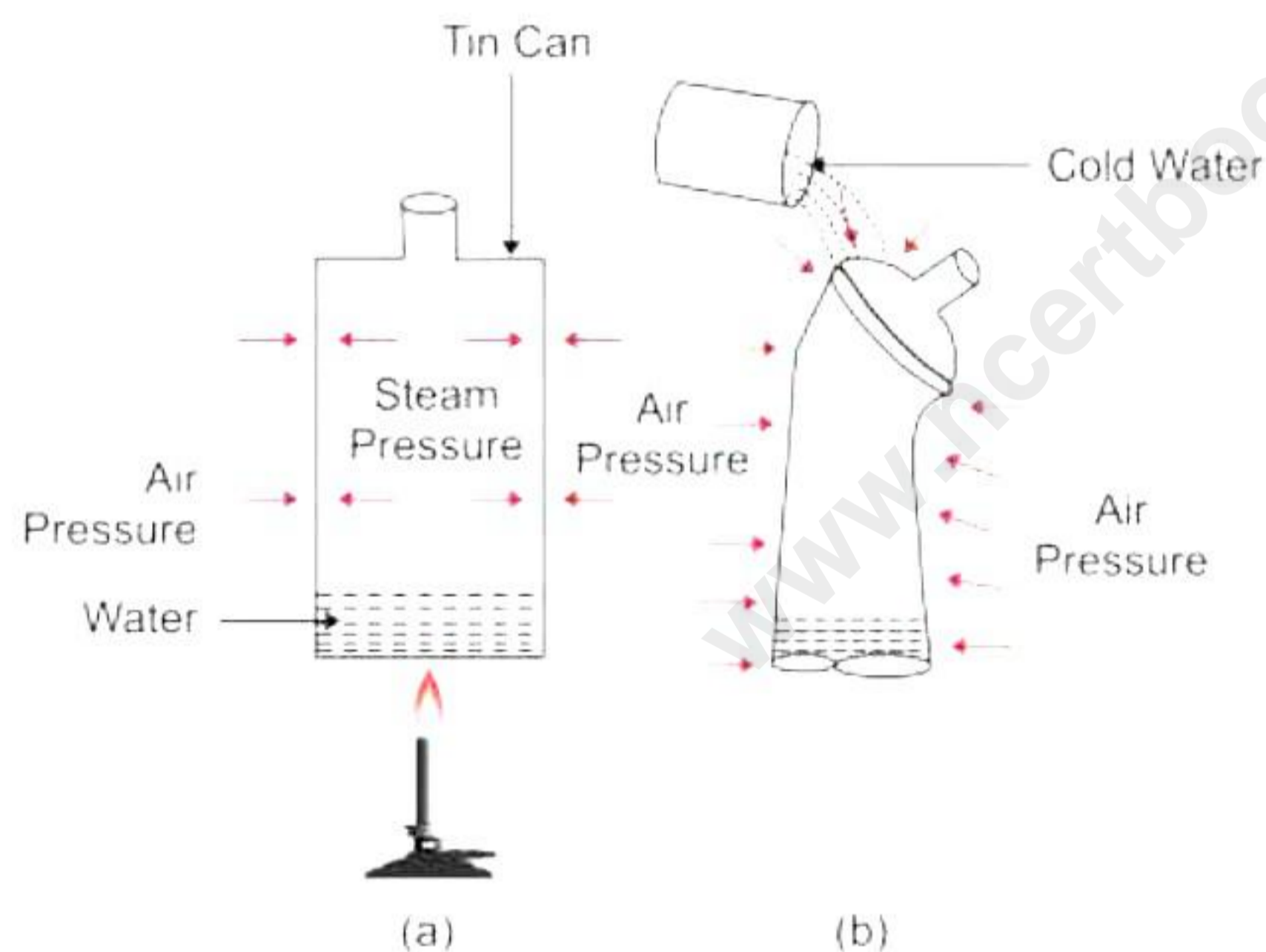

- What is the reason behind the can collapsing inwards? [3]
- (iii) [4]
- a) Describe briefly two adverse consequences of anomalous expansion of water.
- b) A tiles-floor feels very cold to bare feet in winter but a carpet in the same room feels comfortably warm. Why is this?

### Question 8

- (i) A ray of light AB is inclined on a plane mirror  $M_1M_2$  at an angle of  $70^\circ$  from the mirror. The mirror turns through an angle of  $10^\circ$  in the clockwise direction. Draw the ray diagram showing the new reflected ray and determine the angle between the incident ray and the final reflected ray. [3]
- (ii) If you hold a concave mirror in your hand and direct the reflected sunlight continuously on a piece of paper, [3]
- a) What will you observe after some time?

- b) Can you perform this activity with a convex mirror?  
 c) What is the relation between the radius of curvature and the focal length of this mirror?

(iii) [4]

The figure shows the position of a Raj standing at O and the Rashmi who is stand on top of tall building at point I and W is a wall in between them.

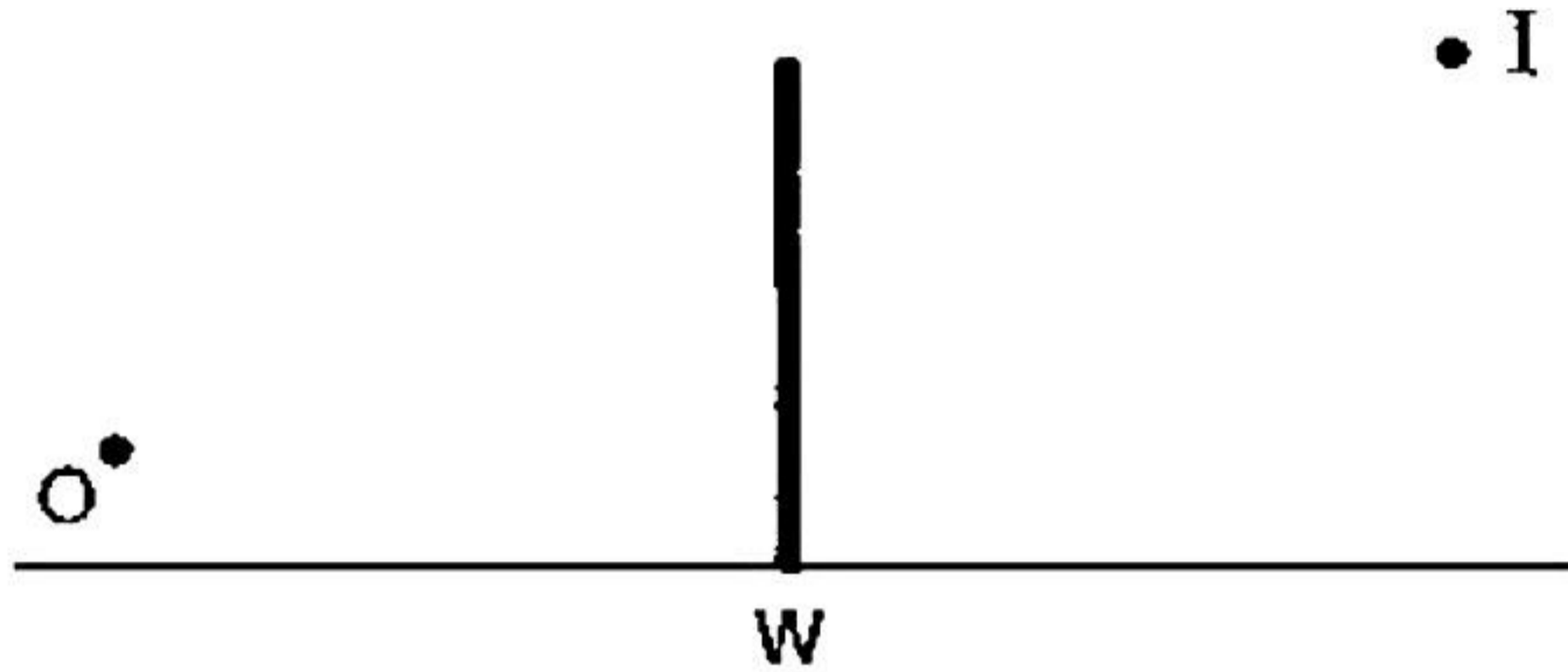

- a) Using two plane mirrors complete the diagram by showing at least one ray, so that Raj observing from O can see the Rashmi at I. Show the angle of incidence and angle of reflection at each mirror.  
 b) Name the optical instrument which Raj can use to observe Rashmi for in question (i).  
 c) Give two applications of plane mirror.  
 d) How many images are formed for a point object kept in between the two plane mirrors at right angles to each other? Show them with the help of a ray diagram.

### Question 9

- (i) The given diagram shows a metal rod mounted on an insulated stand. The cap of an uncharged electroscope touches one end B of the metal rod. A negatively charged polythene rod is brought near the other end A of the metal rod. [3]

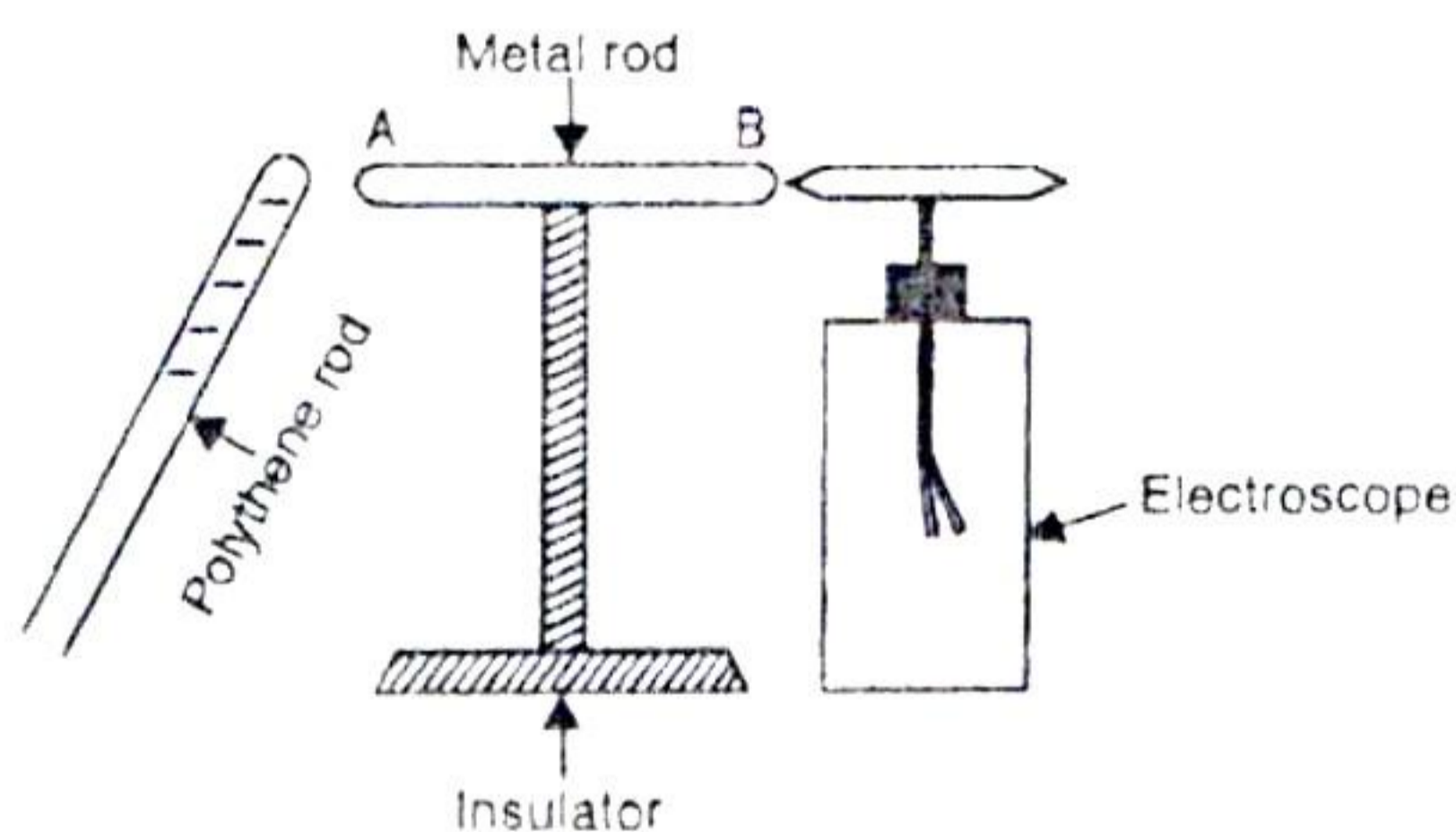

- a) What charge will the end A have?  
 b) What charge will the end B have?  
 c) What charge will the cap of the electroscope have?  
 d) What charge will the gold leaves have?  
 e) Will the leaves diverge or collapse? Give reasons.  
 f) If the electroscope is now earthed, what charge will the metal rod have?

- (ii) Three students, Rohan, Aryan and Riya, are conducting an experiment in their science class to learn about electric circuits. They have set up three different circuits using metal wires, metal cylinders, and light bulbs.

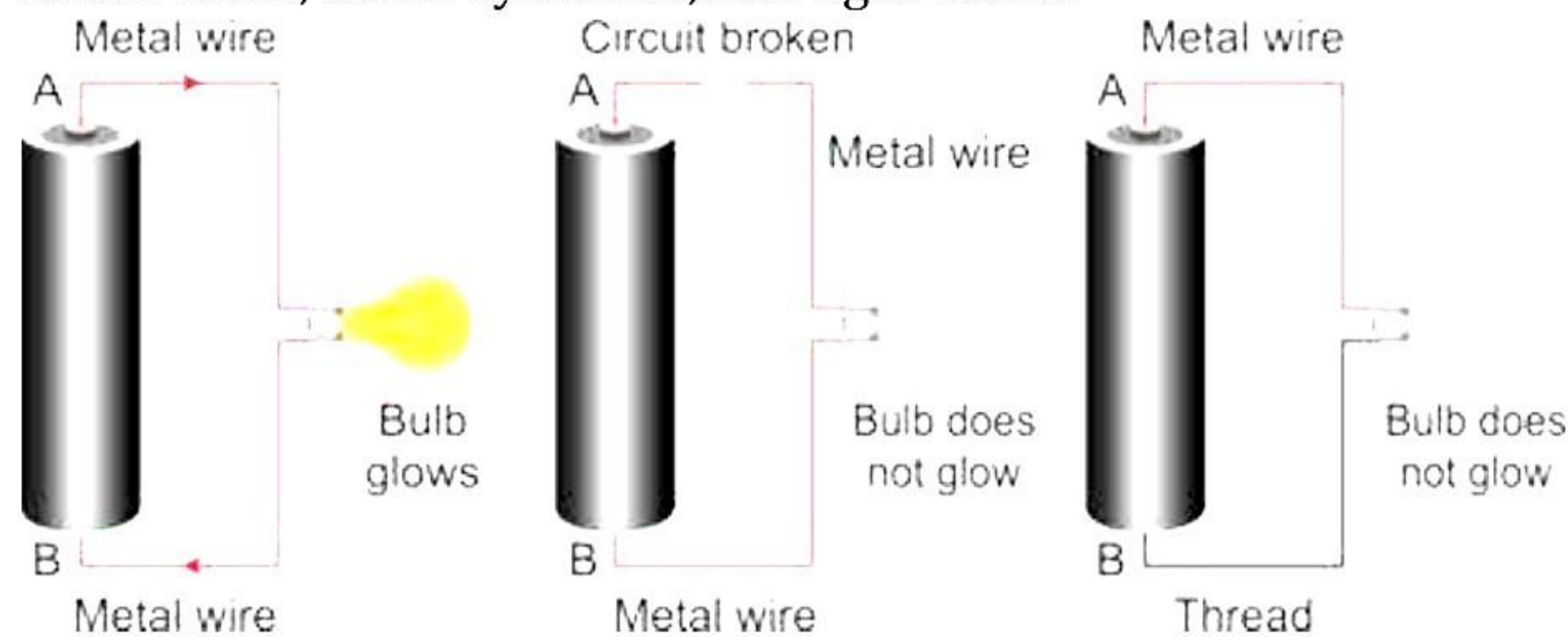

In the first setup, Rohan has created a complete circuit and the light bulb is glowing. In the second setup, Aryan has created a broken circuit and the light bulb is not glowing. In the third setup, Riya has used a thread instead of a metal wire to connect the two metal cylinders, so the circuit is incomplete, and the light bulb is not glowing.

- What is the difference between a complete circuit and an incomplete circuit?
- Why does the light bulb glow in Rohan's setup but not in Aryan's or Riya's setups?
- What is the role of the metal wire in completing the circuit?

- (iii) [4]

- If a magnet is carefully broken into two pieces as shown in diagram (1), how does the magnetic strength of each piece compare with that of the original magnet?

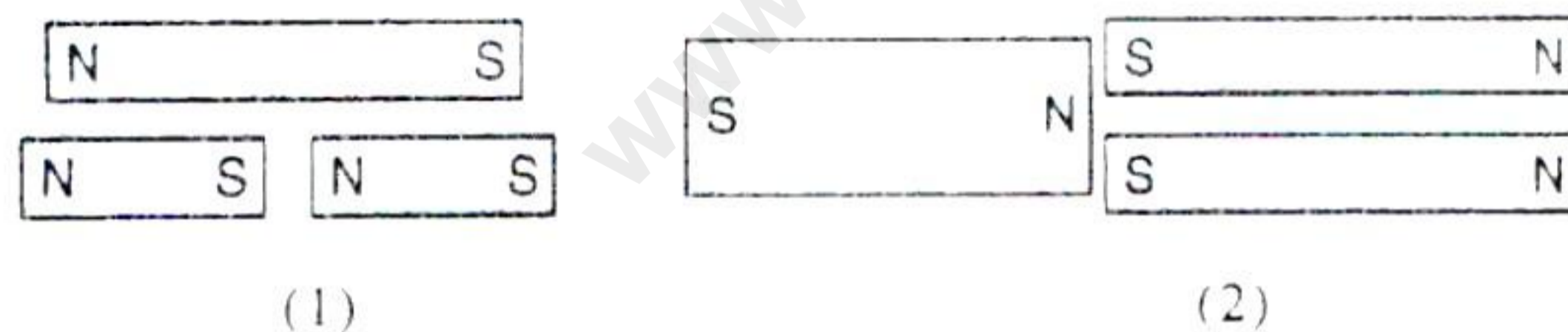

- If another magnet is carefully broken in half along its long axis, as shown in diagram (2), how would the strength of each piece be compared with that of the original magnet?
- Since every iron atom is a tiny magnet, why are not all iron bars magnets?

# Solution

---

## SECTION A

### Solution 1

- (i) Correct option b) increase  
The time period (T) is inversely proportional to the square root of acceleration due to gravity i.e.,  $T \propto 1/\sqrt{g}$ . At an altitude: the value of 'g' decreases. Hence the value of T increases.
- (ii) Correct option - d)  $10^{25}$   
The order of the magnitude is  $10^{25}$   
Since the numerical value  $5.97 > 3.2$   
Thus, Order of magnitude =  $10^1 \times 10^{24} = 10^{25}$
- (iii) Correct option - b) m/s  
The SI unit for velocity is m/s
- (iv) Correct option - b) displacement  
Displacement =  $v \times t$   
Thus, the area enclosed by the velocity-time graph and the time axis will be equal to the magnitude of displacement.
- (v) Correct option - d) Assertion is true but reason is false.  
The assertion is true because speed is defined as the distance travelled per unit time, so its unit can be expressed in terms of units of length and time.  
The reason, however, is false because speed is not considered as one of the basic or fundamental units.  
Hence, for the given case assertion is true reason is false.
- (vi) Correct option - d) He moves backward.  
Child moves in the backward direction as a consequence of action reaction law sandbag exerts an equal and opposite force in the backward direction.
- (vii) Correct option - c) Tension force applied through string.  
Tension force applied through string is a contact force.
- (viii) Correct option - a) Newton's 3rd law  
This is based on Newton's 3rd law of motion which states that--to every action there is an equal and opposite reaction.
- (ix) Correct option - b) 76 cm of Hg  
The normal atmospheric pressures 76 cm of Hg

- (x) Correct option - c) The body of fish contains dissolved oxygen at much higher pressure than the atmospheric pressure.  
The body of the deep-sea fish burst when brought up to the surface of the sea water because the body of fish contains dissolved oxygen at much higher pressure than the atmospheric pressure.
- (xi) Correct option - b) 8 N  
The weight of an object on the Moon is one-sixth its weight on the Earth.  

$$W_M = \left(\frac{1}{6}\right) \times W_E$$

$$W_M = \left(\frac{1}{6}\right) \times 48$$

$$W_M = 8 \text{ N}$$
- (xii) Correct option - c) The combination will sink.  
The combination will sink because initially the weight and density of the combination is equal to that of water. However, on heating the density of the water decreases rapidly as compared to the density of the combination. Thus, upthrust becomes less than the weight of the combination and hence it sinks.
- (xiii) Correct option - d) Equal to the volume of the solid body  
According to Archimedes' principle, the volume of liquid displaced is equal to the volume of the solid.
- (xiv) Correct option - a) 60%  
The increase in the concentration of carbon dioxide due to human activities is responsible for 60% increase in greenhouse effect.
- (xv) Correct option - d) Focal length of the convex mirror is positive and the concave mirror is negative.  
The principal focus of the concave mirror lies on the left side and of convex mirror lies on the right side from the pole. Hence from New Cartesian Sign Conventions, focus of concave mirror is negative and of convex mirror is positive.

## Solution 2

- (i)
- A hydraulic jack is based on **Pascal's** principle.
  - The error induced by wear and tear of screw of a screw gauge is called **Backlash error**.
  - The focal length of a spherical mirror is **half of** its radius of curvature.
  - A lactometer is a special type of hydrometer to measure the purity of milk.
  - The magnetic field lines of earth are **normal** to earth's surface near the magnetic poles and **parallel** to earth's surface near the magnetic equator.
- (ii) Yes, there will be an exchange of mass between the wool and the polythene because electrons are transferred from the wool to the polythene and electrons carry very small but finite mass.

(iii)  $s = 50 \text{ m}$

$$u = 0, a = g = 9.8 \text{ m/s}^2$$

a) Applying second equation of motion,

$$s = ut + \frac{1}{2} at^2$$

$$50 = 0 + \frac{1}{2} (9.8) \times t^2$$

On solving, we get,  $t = 3.19 \text{ s}$

### Solution 3

(i) Diagram (A) represents positive zero error. When the two jaws of vernier calliper are brought together, the **error is said to be positive** if the zero mark of the vernier scale is to the right of the zero mark of the main scale.

(ii) The ratio of time periods of the pendulums with masses 75 g and 125 g will be 1 because the time period of a simple pendulum is independent of its mass.

(iii) Brass, iron are two substances which expand on heating.

(iv) When the velocity remains constant, the velocity-time graph is a straight line parallel to the time axis.

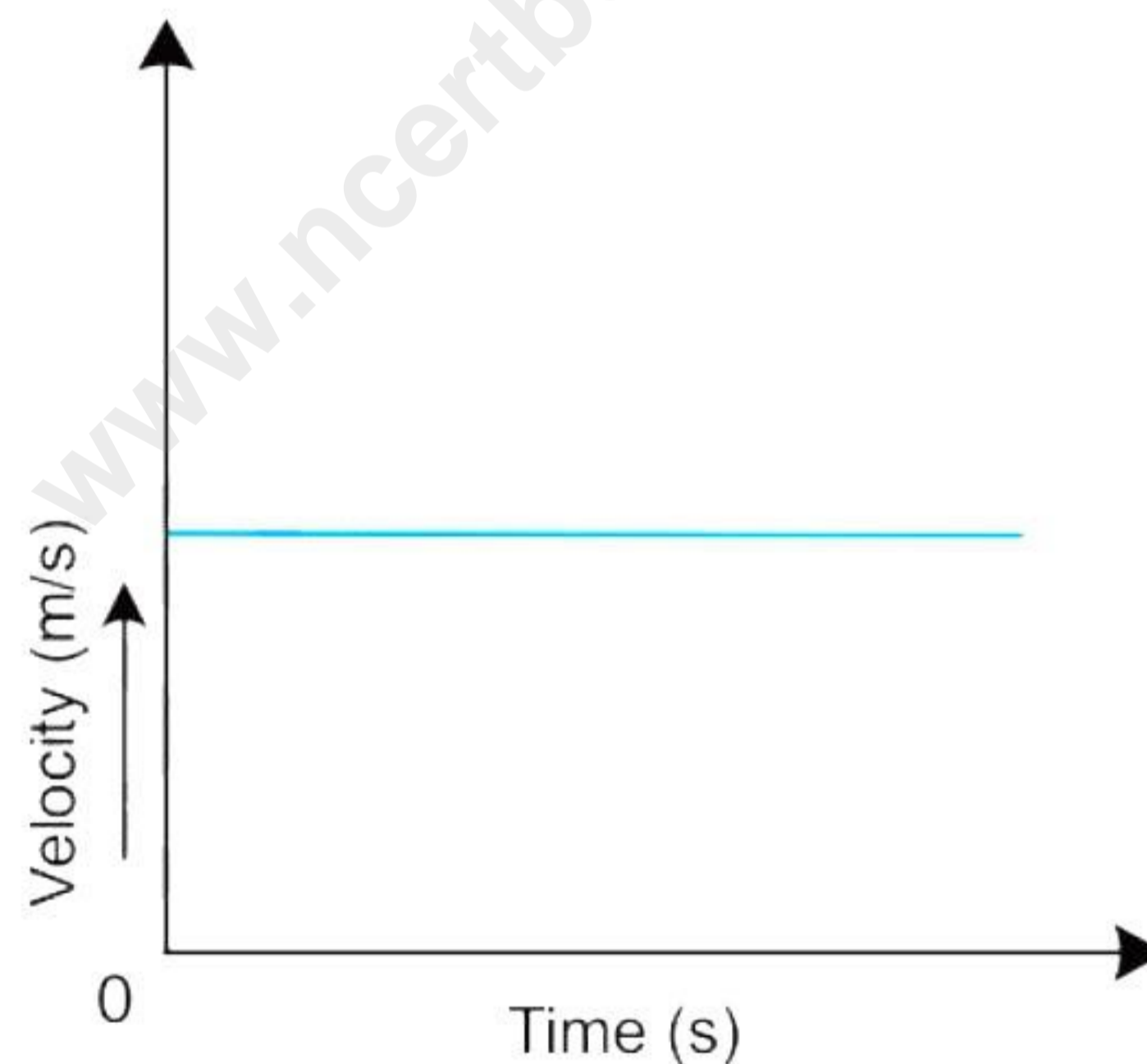

(v) The source of tension in a string on an atomic scale is the inter-atomic restoring force between the molecules.

(vi) The gap will decrease because the metal rod will expand on heating.

(vii) Birds puff up their feathers in winter to trap a large amount of air. Air being a bad conductor, does not allow their body heat to flow out. Thus, birds feel warm.

## SECTION B

### Solution 4

- (i) The pitch of a screw gauge is the linear distance moved by its screw on the main scale when the circular scale is given one complete rotation.

$$\text{Pitch} = \frac{1\text{mm}}{2} = 0.5\text{mm}$$

$$\text{LC} = \frac{\text{Pitch}}{\text{No. of divisions on circular scale}} = \frac{0.5\text{mm}}{50} = 0.01\text{mm}$$

$$\text{MSR} = 0.05\text{cm} = 0.5\text{mm}$$

$$\text{CSR} = 27 \times 0.01\text{mm} = 0.27\text{mm}$$

$$\text{Diameter of wire} = \text{MSR} + \text{CSR}$$

$$= 0.5\text{mm} + 0.27\text{mm}$$

$$= 0.77\text{mm} = 0.077\text{cm}$$

- (ii) Mass of water displaced by the stone,  $m = 1.5\text{ kg}$

We know that,

$$\begin{aligned}\text{Weight} &= \text{Mass} \times \text{Acceleration due to gravity} \\ &= m \times g\end{aligned}$$

$$\text{Weight of the water displaced} = 1.5 \times 9.8\text{ N} = 14.7\text{ N}$$

In accordance with Archimedes' Principle, when an object is wholly or partially immersed in a liquid, it experiences a buoyant force or upthrust which is equal to the weight of the liquid displaced by the object.

The buoyant force acting on the stone is 14.7 N.

- (iii) Force on the table = 8 N

$$\text{Area of the side of the glass slab in contact with table} = 10 \times 10 = 100\text{ cm}^2 = 0.01\text{ m}^2$$

$$\text{Pressure on the table} = \frac{\text{Force}}{\text{Area}} = \frac{8}{0.01} = 800\text{ Pa}$$

$$\begin{aligned}\text{When the slab is tilted, the area of the side of the glass slab in contact with the table} \\ = 10 \times 4 = 40\text{ cm}^2 = 0.004\text{ m}^2\end{aligned}$$

$$\text{Pressure on the table} = \frac{\text{Force}}{\text{Area}} = \frac{8}{0.004} = 2000\text{ Pa}$$

The pressure will increase as the area of contact of the slab with the table decreases.

## Solution 5

(i)

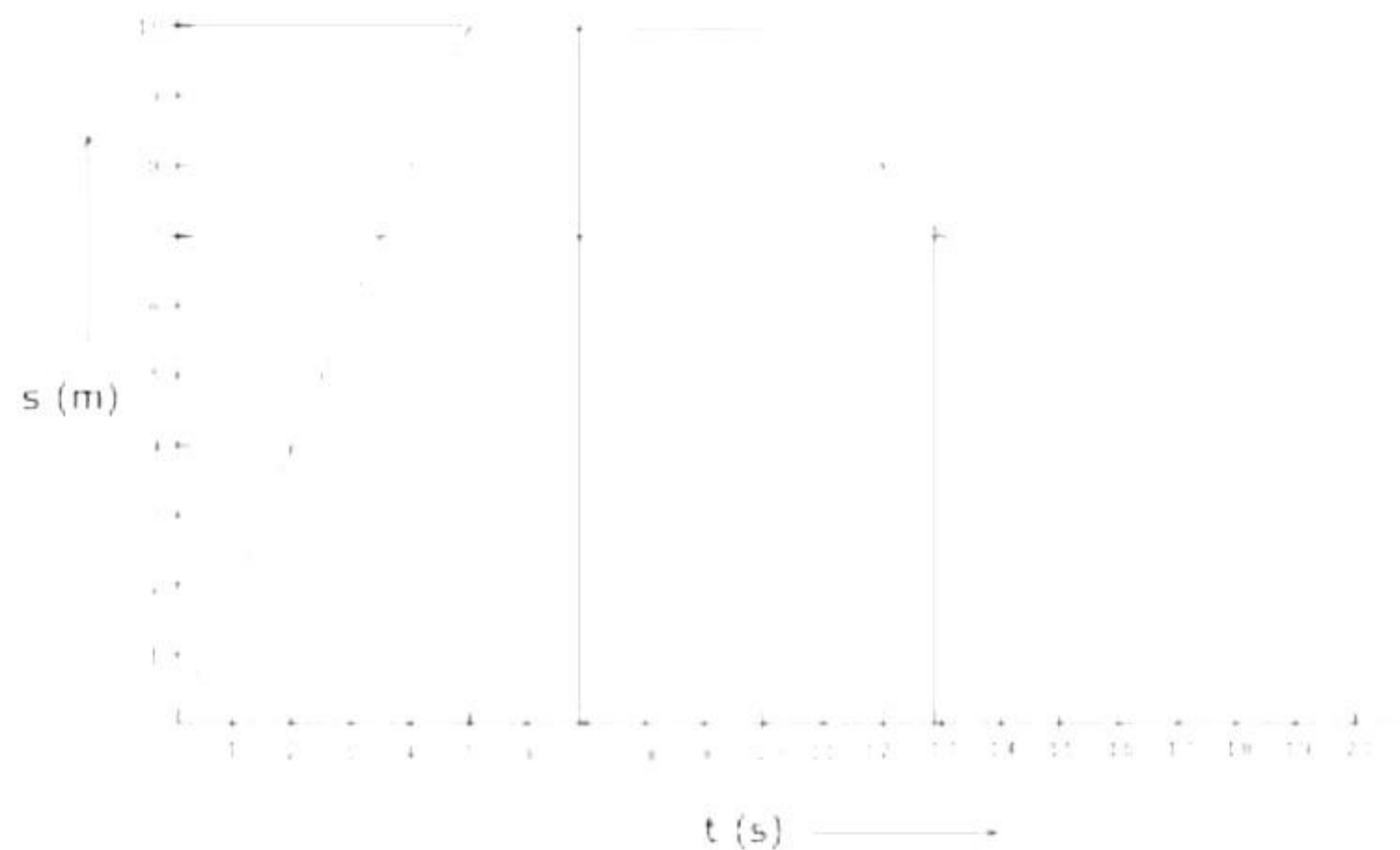

From the graph, we find that

Displacement of the body at 7 s = 10 m

Displacement of the body at 13 s = 7 m

(ii) Initial velocity  $u = 0$

Final velocity  $v = 20 \text{ m/s}$

Distance  $s = 40 \text{ m}$

Using third equation of motion to obtain acceleration

$$v^2 - u^2 = 2as$$

$$20^2 - 0 = 2 \times a \times 40$$

$$a = 400/80 = 5 \text{ m/s}^2$$

To obtain time, we use first equation of motion

$$v = u + at$$

$$t = (v - u)/a$$

$$t = 20/5 = 4 \text{ s}$$

(iii)

a) Runner A won the race. He reached 200 m in the fastest time.

b) Runner C stopped for a rest at 100 m. He stopped for 3.75 seconds.

c) Runner B finished the race in 10.5 seconds.

d) Average Speed of runner A is

$$\text{Speed} = \frac{\text{Distance travelled}}{\text{Time taken}} = \frac{200}{9} = 22.22 \text{ m/s}$$

## Solution 6

(i) The masses of P and Q are equal.

Velocity of P =  $v$

Velocity of Q =  $5v$

Momentum of P,  $M_p = mv$

Momentum of Q,  $M_q = 5mv$

The ratio of momentum  $M_p/M_Q = 1/5$

The inertia is only dependent on the mass of the body; so, the ratio of inertia is 1:1.

(ii) Hydrostatic pressure =  $\rho gh$

where  $h = 1.5 \text{ m}$

$g = 10 \text{ m/s}^2$

$\rho = 1030 \text{ kg/m}^3$

Hydrostatic pressure =  $1030 \times 10 \times 1.5 = 15450 \text{ Pa}$

$1 \text{ Pa} = 10^{-5} \text{ bar}$

$15450 \text{ Pa} = 15450 \times 10^{-5} \text{ bar}$

(iii) Spring balance utilizes the relationship between the applied load and the deformation of a spring. This relationship is usually linear; the more the applied load the more is the deformation of the spring. The body to be weighed is suspended to one end of a hook which is attached to a spring whose pointer is free to move over a scale that is calibrated with standard weights. The body pulls the spring due to gravitational force and its weight is shown on the calibrated scale.

Diagram of a spring balance is as shown in the figure.

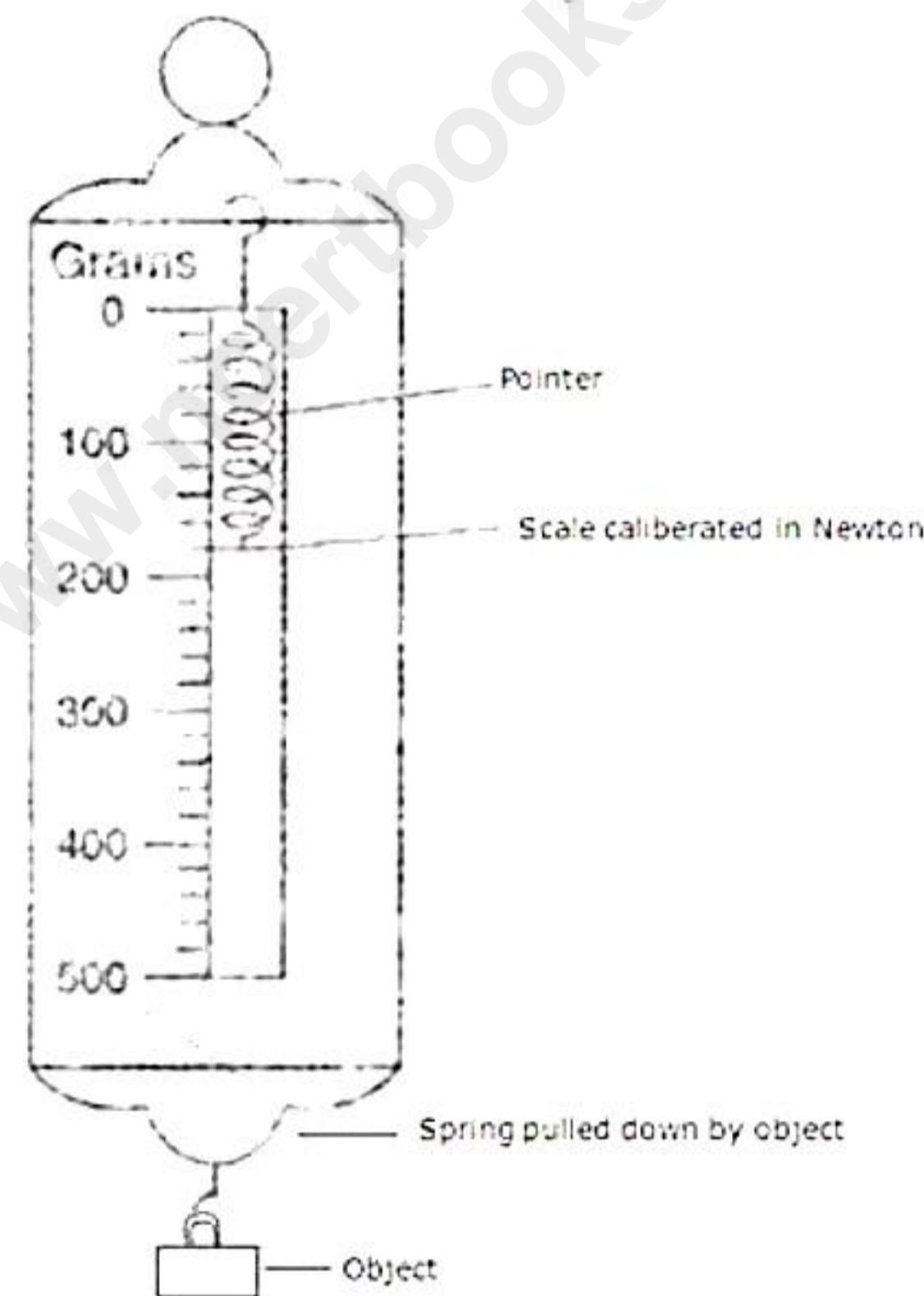

### Solution 7

(i) A freezing mixture is a mixture of two substances, usually ice and salt. The mixture has a low melting point. It is used as cooling bath in laboratories and in ice cream parlors to freeze ice creams. Usually, ice has a melting point of  $0^\circ\text{C}$  and salt is added to lower this melting point of ice.

(ii) The reason is that the pressure due to steam inside the can is same as the air pressure outside the can [Fig (a)]. However, on pouring cold water over the can, fitted with a stopper [fig (b)], the steam inside the can condenses producing water and water vapour at very low pressure. Thus, the air pressure outside the can becomes more than

the vapour pressure inside the closed can. Consequently, the excess atmospheric pressure outside the can causes it to collapse inwards.

(iii)

i. Adverse consequences of anomalous expansion of water:

1. In cold countries, water pipes burst in winters.
2. Ice cream moulds break while freezing the ice-cream.

ii. This is because floor tiles absorb heat rapidly. This means that if you stand bare foot on the tiles, a lot of heat is drawn out of your foot. A carpet, in comparison absorbs heat slowly. This makes the tiles-floor feel colder than a carpet when they are actually the same temperature.

### Solution 8

(i) Initially, the ray diagram is

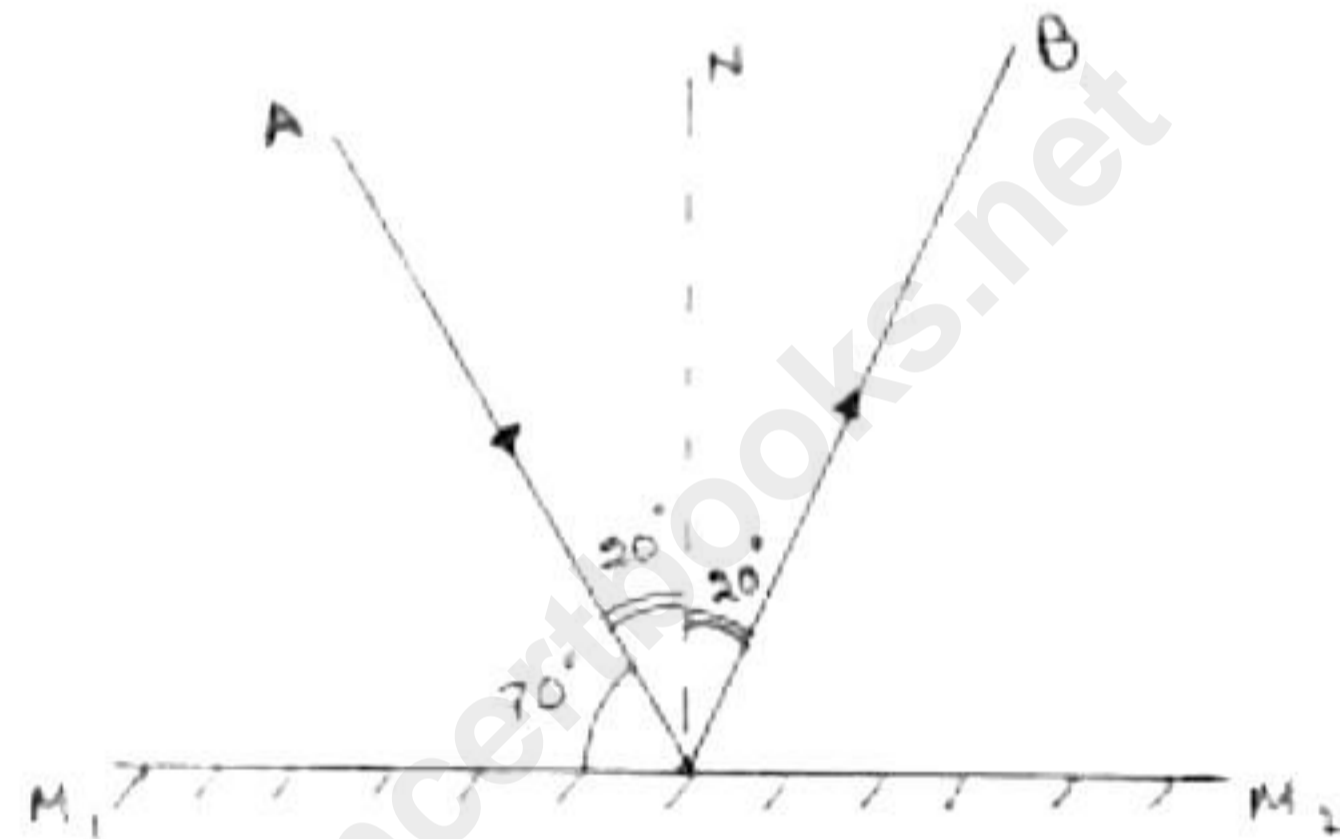

After tilting the mirrors by  $10^\circ$ , the incident angle becomes  $60^\circ$ . The ray diagram is

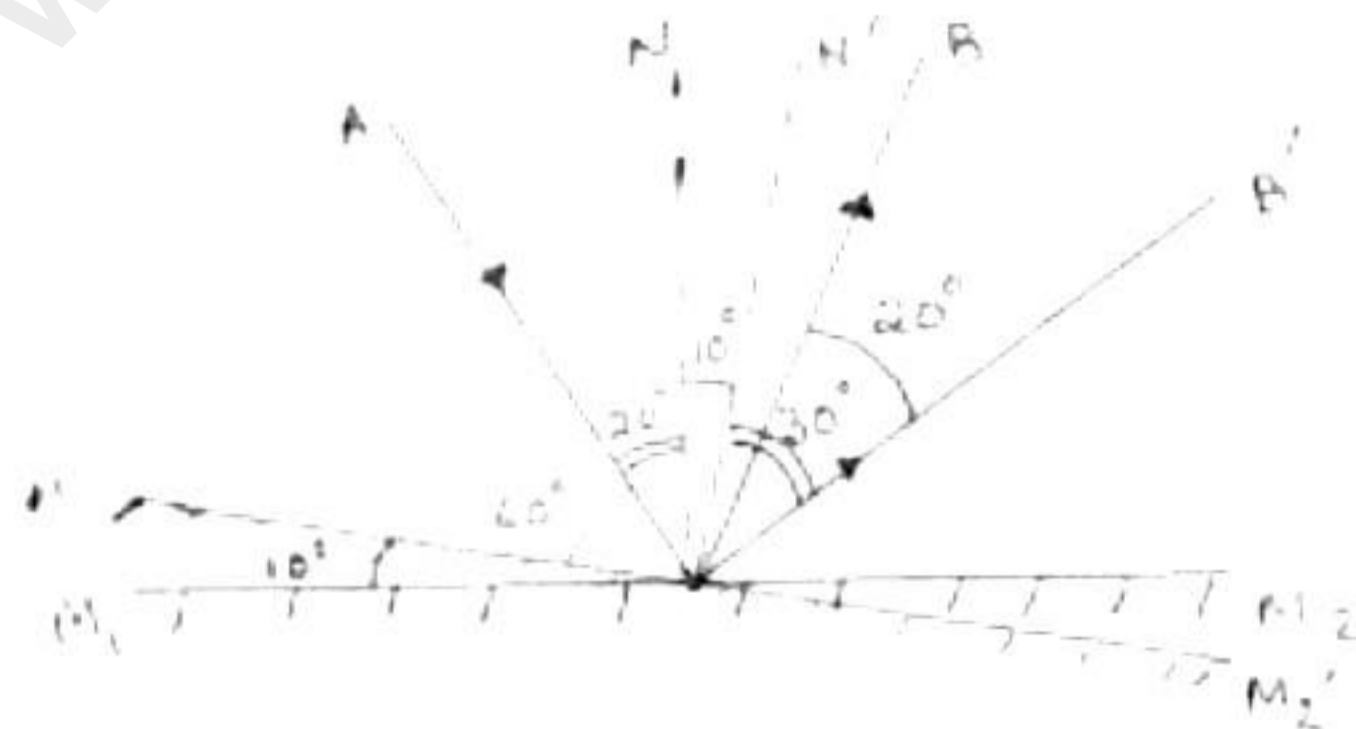

Angle between incident ray and final reflected ray =  $30^\circ + 30^\circ = 60^\circ$

(ii)

- a) We will observe that the paper starts burning.
- b) No, because a convex mirror diverges the light rays incident on it.
- c) Radius of curvature is twice the focal length of the mirror,  $R = 2f$

(iii)

a) The ray diagram is shown in the figure.

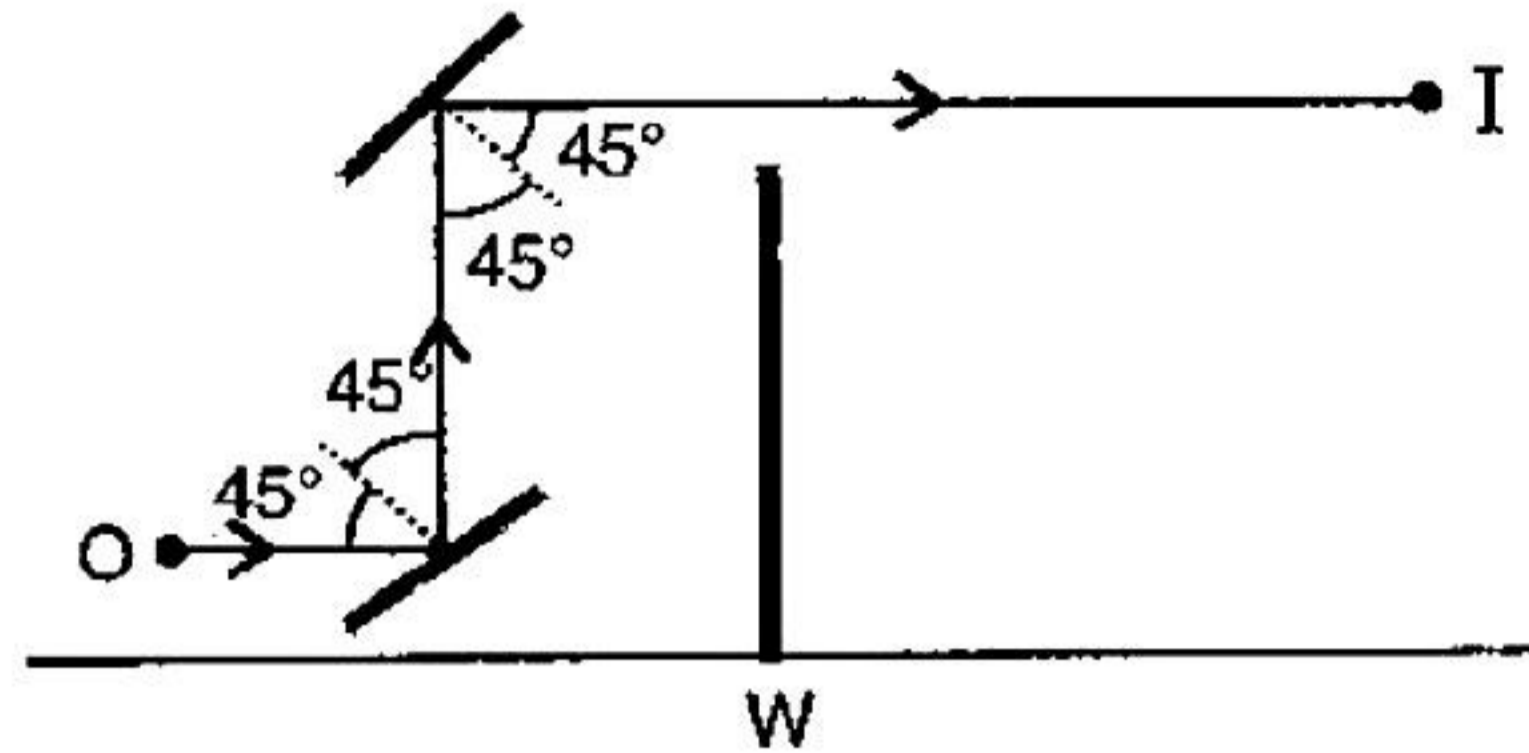

b) Periscope

c) Three applications of a plane mirror are:

- Plane mirrors are used in many optical instruments.
- Plane mirrors are used in periscopes and kaleidoscopes.
- They are used in dressing rooms to see ourselves.

d) For two mirrors kept perpendicular to each other, three images are formed for an object kept in between them.

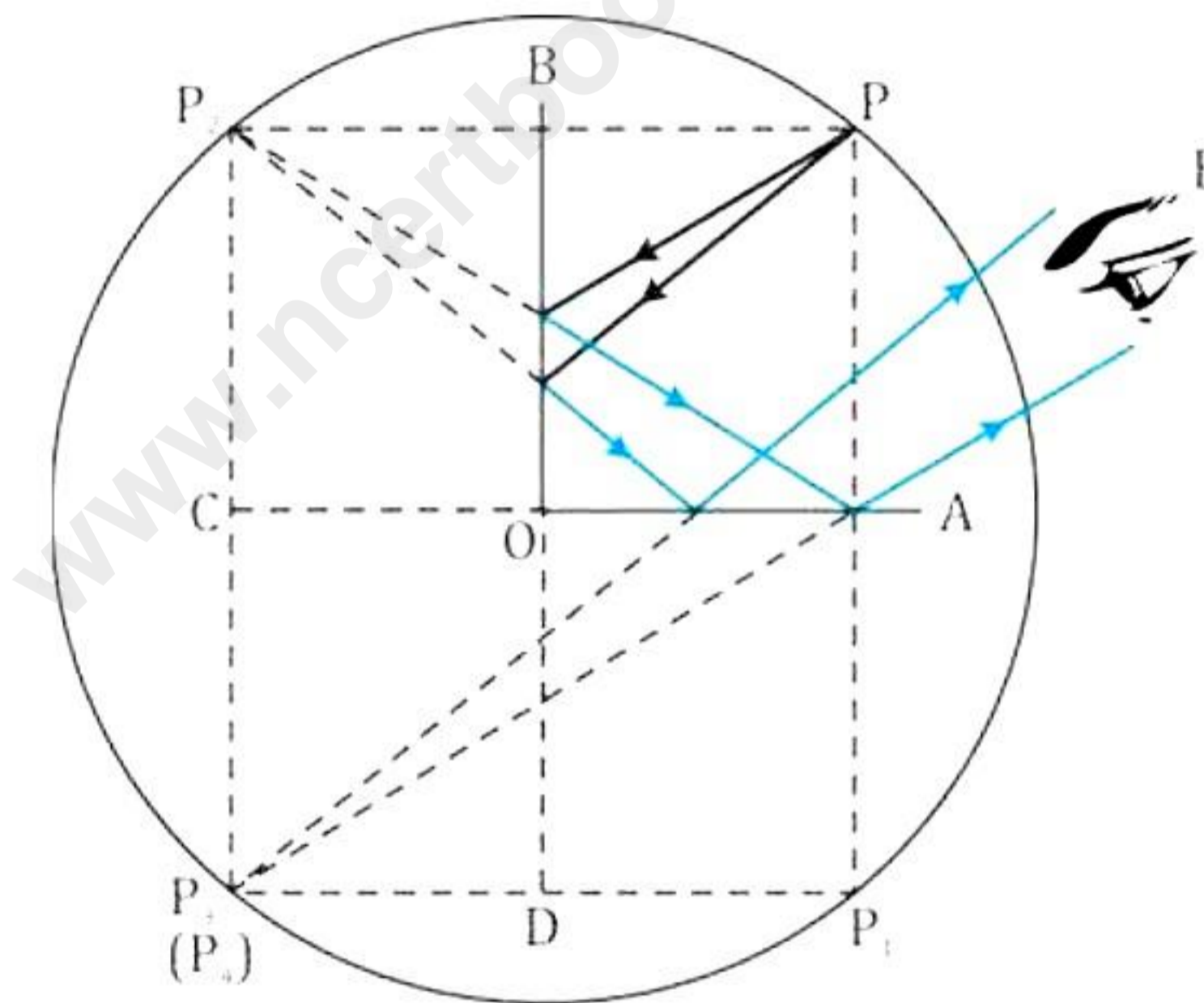

### Solution 9

(i)

- End A will have a positive charge.
- End B will have a negative charge.
- The cap of the electroscope will have a negative charge.
- The charge on the gold leaves will be negative.
- Leaves will diverge by repelling each other.
- If the electroscope is now earthed then the charge on metal rod will be positive.

(ii)

- a) A complete circuit is a closed loop of conductive material that allows electric current to flow through it, while an incomplete circuit is an open loop that does not allow electric current to flow.
- b) The light bulb glows in Rohan's setup because he has created a complete circuit, which allows electric current to flow through the metal wire, metal cylinders, and light bulb, causing the bulb to glow. Whereas in Aryan's setup, the circuit is broken, so no electric current can flow, and the light bulb does not glow. And finally in Riya's setup, the thread is not a conductor, so it does not allow electric current to flow, and the circuit is incomplete, causing the light bulb to not glow.
- c) The metal wire plays a crucial role in completing the circuit by providing a conductive path for electric current to flow between the two metal cylinders. Without the metal wire, there would be no closed loop for electric current to flow and the circuit would be incomplete.

(iii)

- a) The magnetic strength reduces to half.
- b) The magnetic strength reduces to half.
- c) Not all iron bars are magnets because the molecular magnets present in the iron bars are randomly aligned. For an iron bar to be a magnet, the molecular magnets should be aligned in one direction.