

**PHYSICS**  
**PAPER – 1**  
**(THEORY)**

**PART I (20 Marks)**

*Answer all questions.*

**Question 1**

A. Choose the correct alternative (a), (b), (c) or (d) for each of the questions given below: **[5]**

- (i) In **Figure 1** below, a charge  $Q$  is fixed. Another charge  $q$  is moved along a circular arc MN of radius  $r$  around it, from the point M to the point N such that the length of the arc  $MN = l$ . The work done in this process is:

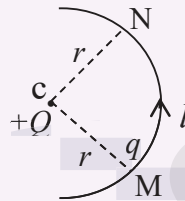

**Figure 1**

- (a) zero  
 (b)  $\frac{1}{4\pi\epsilon_0} \cdot \frac{Qq}{r^2} l$   
 (c)  $\frac{Qq}{2\epsilon_0 r^2} l$   
 (d)  $\frac{Qq}{2\pi\epsilon_0 r^2}$
- (ii) A carbon resistor has coloured bands as shown in **Figure 2** below. The resistance of the resistor is:

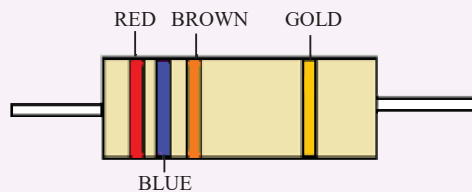

**Figure 2**

- (a)  $26\Omega \pm 10\%$   
 (b)  $26\Omega \pm 5\%$   
 (c)  $260\Omega \pm 5\%$   
 (d)  $260\Omega \pm 10\%$

- (iii) A solenoid L and a resistor R are connected in series to a battery, through a switch. When the switch is put on, current I flowing through it varies with time t as shown in which of the graphs given below:

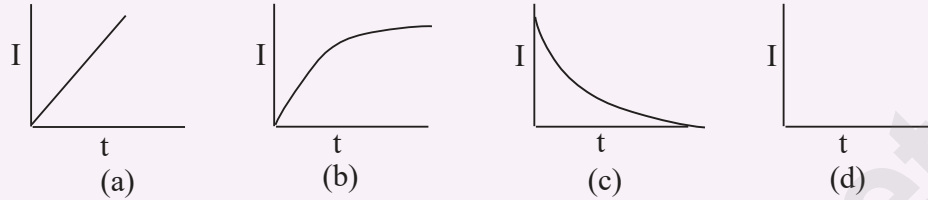

- (iv) Two thin lenses having optical powers of  $-10\text{D}$  and  $+6\text{D}$  are placed in contact with each other. The focal length of the combination is:
- (a)  $+0.25\text{ cm}$   
 (b)  $-0.25\text{ cm}$   
 (c)  $+0.25\text{ m}$   
 (d)  $-0.25\text{ m}$
- (v) Total energy of an electron in the **ground state** of hydrogen atom is  $-13.6\text{ eV}$ . Its total energy, when hydrogen atom is in the **first excited state**, is:
- (a)  $+13.6\text{ eV}$   
 (b)  $+3.4\text{ eV}$   
 (c)  $-3.4\text{ eV}$   
 (d)  $-54.4\text{ eV}$

**B.** Answer **all** questions given below **briefly** and to the point:

[15]

- (i) A charged oil drop weighing  $1.6 \times 10^{-15}\text{ N}$  is found to remain suspended in a uniform electric field of intensity  $2 \times 10^3\text{ NC}^{-1}$ . Find the **charge** on the drop.
- (ii) For a metallic conductor, what is the relation between **current density** (J), **conductivity** ( $\sigma$ ) and **electric field intensity** E?
- (iii) In **Figure 3** given below, find the value of resistance X for which points A and B are at the same potential:

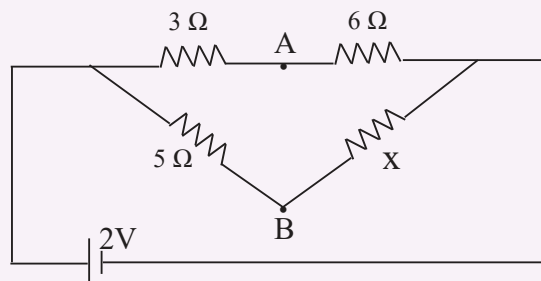

**Figure 3**

- (iv) Write the expression for the **Lorentz force** **F** in vector form.

- (v) A coil has a **self-inductance** of 0.05 Henry. Find magnitude of the emf induced in it when the current flowing through it is changing at the rate  $100 \text{ As}^{-1}$ .
- (vi) To which regions of the **electromagnetic spectrum** do the following wavelengths belong:
- (a) 250 nm  
(b) 1500 nm
- (vii) What is the difference between **polarised light** and **unpolarised light**?
- (viii) Name the **principle** on the basis of which **optical fibres** work.
- (ix) Calculate **dispersive power** of a transparent material given:  

$$n_v = 1.56, n_r = 1.54, n_y = 1.55.$$
- (x) What is meant by **short-sightedness**?
- (xi) Two metals A and B have work functions 4eV and 6eV respectively. Which metal has lower **threshold wavelength** for photoelectric effect?
- (xii) Calculate **angular momentum** of an electron in the **third Bohr orbit** of hydrogen atom.
- (xiii) In a nuclear reactor, what is the function of a **moderator**?
- (xiv) In our Nature, where is the **nuclear fusion** reaction taking place continuously?
- (xv) What is the use of a **Zener diode**?

#### Comments of Examiners

- A (i) A few candidates' answer was incorrect.
- (ii) A number of candidates answered this question incorrectly.
- (iii) A few candidates did not understand that 'switch is on' means growth of current. Hence, they selected the wrong option.
- (iv) Some candidates chose the wrong option 'b' instead of correct option (d).
- (v) A few candidates chose the wrong option 'b' in place of 'c'.
- B. (i) Some candidates did not write the correct formula. In some cases, mistakes were made in substitution. A few candidates did not write the correct unit.

#### Suggestions for teachers

- explain to students the concept of equipotential surface and work done in moving a charge on an equipotential surface is Zero.
- Colour coding of carbon resistors must be correctly explained with the help of examples.
  - Meaning of ground state and excited state must be made clear, with the help of examples, specially for hydrogen.

- (ii) Some candidates gave wrong relations or gave a relation involving 'E' instead of  $\sigma$ .
- (iii) Some candidates wrote the answer directly without the formula, working, etc. They did not realise that it was a balanced Wheatstone bridge.
- (iv) A few candidates did not know what Lorentz force is; some did not write it in vector form/ did not put arrows on V, E or B. In some cases, the order of V & B was wrong.
- (v) A number of candidates did not use the correct formula  $e = \pm L di/dt$ . Some gave wrong unit of 'e' or did not mention the unit.
- (vi) Many candidates could not answer this question correctly. They were unable to correlate given wavelength with the correct electromagnetic radiation.
- (vii) Many candidates did not mention – 'the direction of propagation of light'.
- (viii) Some candidates wrote 'reflection', instead of total internal reflection.
- (ix) Candidates used incorrect formulae; in a few cases, the rounding off was incorrect.
- (x) Some candidates got confused between 'short sightedness' and 'long sightedness' and gave incorrect definition. Some drew wrong diagrams. Instead of a distant object, candidates showed a nearby object and rays being focussed behind the retina.
- (xi) A few candidates answered incorrectly as they did not know the relation between work function and threshold wavelength.
- (xii) A few candidates did not solve the answer fully. Some gave the wrong unit of I.
- (xiii) A few candidates got confused between moderator and control rods. They gave answers such as:
  - It controls the speed of neutrons (instead of slowing them down).
  - It controls the temperature.
  - It controls the electrons.
- (xiv) A few candidates wrote the answer as 'earth's crust'. Some wrote volcano, fusion bomb & nuclear reactors instead of sun/stars.
- (xv) A few candidates defined Zener diode instead of stating its use. Some explained the working of Zener diode. Several candidates wrote, regulator/stabilizer, instead of voltage regulator/stabilizer.

- Students must be trained/asked to read questions very carefully and answer accordingly.
- While solving a numerical problem, students must first write correct formula. Then, known quantities must be substituted in SI system. Finally, the answer must be written with unit. It must be emphasized from the beginning that without unit, a physical quantity is meaningless.
- Train students to find induced emf using different formulae. Train them to write answers with proper unit.
- Students must be given approximate wavelength ranges for all the electromagnetic radiations and they should be asked to learn these ranges by heart.
- Difference between polarized light and unpolarised light must be explained clearly.
- The phenomenon of total internal reflection, its meaning, when it occurs and its advantages should be made clear to students.
- Meaning of shortsightedness as well as long sightedness must be explained to students with the help of diagrams. Ask students to practice these diagrams.
- Train students to substitute the values of all known physical quantities and constants and solve to get final answer, correct up to 3sf., with correct unit.
- While describing different parts of a nuclear reactor, their functions and uses must be explained clearly.

**MARKING SCHEME**

**Question 1.**

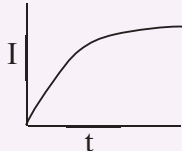
A.	(i)	(a) or zero
	(ii)	(c) or $260(\Omega) \pm 5\%$
	(iii)	(b) or 
	(iv)	(d) or $-0.25 \text{ m}$
	(v)	(c) or $-3.4 \text{ (eV)}$
B.	(i)	$q\left(= \frac{F}{E}\right) = \frac{1.6 \times 10^{-15}}{2 \times 10^3} = 8 \times 10^{-19} \text{ C or } 5e$
	(ii)	$J = \sigma E$ OR $\vec{j} = \sigma \vec{E}$
	(iii)	$\frac{3}{6} = \frac{5}{x} \Rightarrow x = 10 \Omega$ OR $\frac{3}{5} = \frac{6}{x} \Rightarrow x = 10 \Omega$ OR $x = 10 \Omega$ , directly, since it is a balanced Wheatstone bridge
	(iv)	$\vec{F} = q(\vec{v} \times \vec{B})$ OR $q(\vec{v} \times \vec{B})$ OR $q(\vec{E} + \vec{v} \times \vec{B})$
	(v)	$(e) = l \frac{dl}{dt} / 0.05 \times 100 = 5V$ , $e = -5V$ is also acceptable.
	(vi)	Ultra violet or uv (region)
	(b)	Infra-red (region)
	(vii)	In unpolarised light, electric vector (or $\vec{E}$ ) points in infinite (or many) directions, all perpendicular to $\vec{c}$ (or direction of propagation) whereas in polarised light, it points in one direction only.
	(viii)	Total internal reflection (or T.I.R. or t.i.r.)
	(ix)	$(\omega) = \frac{(n_v - n_r)}{(n_y - 1)}$ OR $\omega = \frac{1.56 - 1.54}{1.55 - 1}$ $= 0.0364$ or $0.036$
	(x)	It is that defect of vision in which a person: (a) Is unable to see distant objects (b) Can see nearby objects only

(xi)	B
(xii)	$(l_3) = \frac{3h}{2\pi}$ / or $l_3 = \frac{3 \times 6.6 \times 10^{-34}}{2\pi}$ $= 3.15 \times 10^{-34} \text{ Js}$
(xiii)	It slows down fast moving neutrons. Or It converts high speed neutrons to slow neutrons Or It produces thermal neutrons. Or It converts high energy neutrons to slow moving or thermal neutrons.
(xiv)	Sun or a star
(xv)	It is used for voltage regulation Or It is used as a voltage regulator Or It is used as a voltage stabilizer Or It converts a fluctuating voltage to a steady voltage.

### PART II (50 Marks)

Answer **ten** questions in this part, choosing **four** questions from Section A, **three** questions from Section B and **three** questions from Section C.

#### SECTION A

Answer any **four** questions.

#### Question 2

- (a) Two point charges  $Q_1 = 400\mu\text{C}$  and  $Q_2 = 100\mu\text{C}$  are kept fixed, 60 cm apart in vacuum. [3]  
 Find **intensity** of the electric field at **midpoint** of the line joining  $Q_1$  and  $Q_2$ .
- (b) (i) State **Gauss' Law**. [2]  
 (ii) In an electric dipole, at which point is the **electric potential** zero?

Comments of Examiners

- (a) Several candidates used wrong formula to calculate E. Some others did not convert  $\mu\text{C} \rightarrow \text{C}$  and  $\text{cm} \rightarrow \text{m}$ . They used wrong value of r i.e. 0.6m instead of 0.3m. A few candidates could not find resultant intensity E, ( $E = E_1 - E_2$ ). Some candidates did not write the unit of E, while others gave wrong unit.
- (b) (i) Most of the candidates could not state Gauss' Law correctly: key words like, net charge, closed surface etc. were missing. Some candidates wrote magnetic flux, instead of electric flux.
- (ii) A few candidates gave the answer as, 'equilateral' in place of 'equatorial line'. A few wrote 'infinity'.

Suggestions for teachers

- Make students learn the correct formulae and give enough practice in numericals. They should be trained to get units in the SI. System.
- Students should be taught the formulae with the correct understanding of the symbols. They should also be trained to deal with vector quantities.
- State and explain Gauss' Law.
- Derive an expression for electric potential in broad side position of electric dipole and emphasize that  $V = 0$  along the entire perpendicular bisector of the dipole. It is a very interesting situation where  $V = 0$  and E is not.

<b>MARKING SCHEME</b>	
<b>Question 2.</b>	
(a)	$E_1 = \left( \frac{1}{4\pi\epsilon_0} \right) \frac{Q_1}{r_1^2} /$ $= 9 \times 10^9 \times \frac{400 \times 10^{-6}}{0.3^2}$ $= 4 \times 10^7 \text{ NC}^{-1}$ $E_2 = 1 \times 10^7 \text{ NC}^{-1}$ $E = (E_1 - E_2)$ $= 3 \times 10^7 \text{ N/C} \quad \text{OR}$ $E = (E_1 - E_2)$ $= 9 \times 10^9 \left( \frac{400 \times 10^{-6}}{0.3^2} - \frac{100 \times 10^{-6}}{0.3^2} \right)$ $= 3 \times 10^7 \text{ NC}^{-1}$
(b)	<p>(i) Electric flux (emanating) through a closed (or a Gaussian) surface is a ratio of (net) charge enclosed by the surface to the permittivity of vacuum. OR</p> $\Phi_{(E)} = \frac{q_{net}}{\epsilon_0}$ <p style="text-align: right;">OR</p> $\oint \vec{E} \cdot \vec{ds} = \frac{q}{\epsilon_0}$

	(ii)	(A point) in broad side position OR (A point) in an equatorial plane OR (A point) on an equatorial line OR (A point) on perpendicular bisector of the dipole or centre or mid-point
--	------	--

### Question 3

- (a) Obtain an expression for **equivalent capacitance** when three capacitors  $C_1$ ,  $C_2$  and  $C_3$  are connected in **series**. [3]
- (b) A metallic wire has a resistance of  $3.0\Omega$  at  $0^\circ\text{C}$  and  $4.8\Omega$  at  $150^\circ\text{C}$ . Find the **temperature coefficient of resistance** of its material. [2]

#### Comments of Examiners

- (a) Some candidates did not draw and label the diagram. They did not show charges  $Q_1 = Q_2 = Q_3 = Q$  and some did not show p.d's i.e.  $v_1, v_2, v_3$ . A few candidates did not derive the expression of equivalent capacitance and just wrote the final formula i.e.:

$$\frac{1}{c} = \frac{1}{c_1} + \frac{1}{c_2} + \frac{1}{c_3}$$

- (b) Some candidates used incorrect formulae like  $\alpha = \frac{R_t - R_0}{R_0}$  Or  $\alpha = \frac{R_2 - R_1}{R_2 t_1}$  Some converted  $^\circ\text{C} \rightarrow \text{Kelvin}$ , resulting in wrong substitution. Some candidates did not write the unit whereas a few gave wrong unit.

#### Suggestions for teachers

- Tell students to draw completely labelled diagrams for derivations. They should learn the derivation by heart and practice them at home.

- Make students learn the correct formulae and ask them to solve/practice numericals at home. Some numericals must be solved in class, to explain correct use of formulae. Explain to students when

to use  $\alpha = \frac{R_t - R_0}{R_0 t}$  then to use

$$\alpha = \frac{R_2 - R_1}{R_1 t_2 - R_2 t_1}$$

### MARKING SCHEME

#### Question 3.

(a)

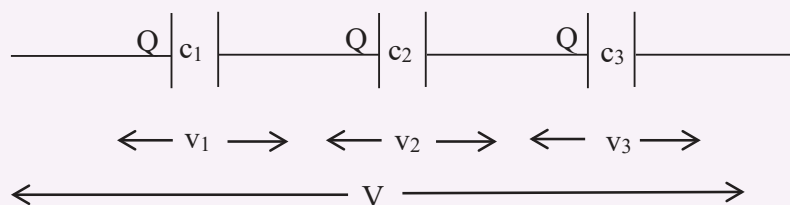

Correct diagram

$$V = v_1 + v_2 + v_3$$

$$\frac{Q}{c} = \frac{Q}{c_1} + \frac{Q}{c_2} + \frac{Q}{c_3}$$

	$\therefore \frac{1}{c} = \frac{1}{c_1} + \frac{1}{c_2} + \frac{1}{c_3}$
(b)	$\alpha = \frac{R_t - R_0}{R_0 \cdot t}$ <p>Correct formula or correct substitution.</p> $= \frac{4.8 - 3.0}{3.0 \times 150}$ $= 4 \times 10^{-3} / ^\circ\text{C}$ <p><math>R_t = R_0 (1 + \alpha t)</math> can also be used</p>

#### Question 4

- (a) In the circuit shown in **Figure 4** below,  $E_1$  and  $E_2$  are two cells having emfs 2V and 3V respectively, and negligible internal resistances. Applying **Kirchoff's laws** of electrical networks, find the values of currents  $I_1$  and  $I_2$ . [4]

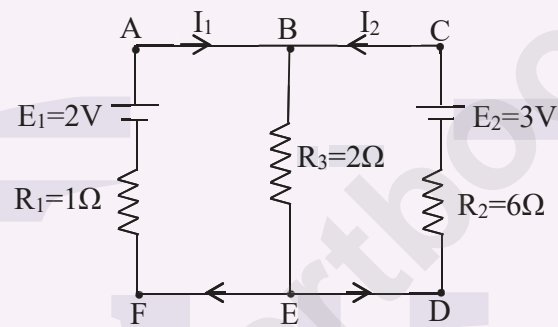

**Figure 4**

- (b) State how a moving coil galvanometer can be converted into an ammeter. [1]

#### Comments of Examiners

- (a) Junction rule i.e.  $I_3 = I_1 + I_2$ , was not applied in several cases. Loops not mentioned while applying Kirchoff's 2<sup>nd</sup> Law. Some candidates could not apply Kirchoff's 2<sup>nd</sup> Law to the loops correctly. The final answer was not given with units / left in fraction.
- (b) A few candidates got confused between conversion of G to A and conversion of G to V. Hence, they drew wrong diagram. Some drew the diagram correctly but did not write 'shunt' or 'low resistance'.

#### Suggestions for teachers

- Explain Kirchoff's junction rule and loop rule. Solve a few numericals based on Kirchoff's Laws.
- Tell students that an ammeter is a low resistance instrument. Hence, a low resistance called shunt has to be connected in parallel with the coil of the Galvanometer. A voltmeter is a high resistance instrument. To increase the resistance, we have to convert a high resistance in series. Ask students to practise these diagram.

**MARKING SCHEME****Question 4.**

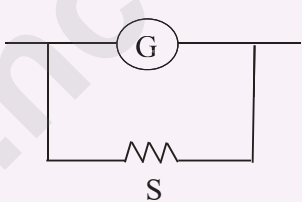
(a)	$i_3 = i_1 + i_2$ <p>(Applying Kirchoff's 2<sup>nd</sup> Law to) loop ABEF(A) or loop shown in diagram</p> $2i_3 + 1i_1 = 2$ <p>OR</p> $2(i_1 + i_2) + 1i_1 = 2$ <p>(Applying Kirchoff's II Law to the) Loop CBED(C) or loop shown in diagram</p> $2i_3 + 6i_2 = 3$ <p>OR</p> $2(i_1 + i_2) + 6i_2 = 3$ <p>Solving these two equations, we get</p> $i_1 = 0.5A$ $i_2 = 0.25A$
(b)	By connecting a low resistance in parallel with its coil. OR By connecting a shunt (in parallel) with its coil. OR Correct diagram, i.e., 

**Question 5**

- (a) Draw a labelled circuit diagram of a **potentiometer** to measure **internal resistance** of a cell. Write the working formula. (*Derivation not required*). [3]
- (b) (i) Define **Curie temperature**. [2]
- (ii) If magnetic susceptibility of a certain magnetic material is 0.0001, find its **relative permeability**.

### Comments of Examiners

(a) A few candidates drew the diagram of metre bridge in place of potentiometer. Many candidates could not draw the correct circuit diagram. Some common mistakes observed were:

- Experimental cell was wrongly connected.
- Key  $K_2$  was shown with the cell, rather than with standard resistor.
- In some cases,  $K_2$  was not used,  $G$  was left out.
- Labelling of components was missing or incomplete.
- In several cases, the working formula was incorrect: given in terms of  $E$  &  $V$ , rather than  $L_1$  &  $L_2$ .

(b) (i) Many candidates stated Curie Law rather than Curie temperature. A few even defined Curie – the unit of radio activity. Some candidates wrongly defined Curie temperature as the temperature at which (a) material loses its magnetism (b) Paramagnetic substance becomes diamagnetic.

E

(ii) Several candidates used wrong formulae; a few wrote a unit for  $\mu_r$ , though it has no unit.

### Suggestions for teachers

- Draw the correct circuit diagram on board while teaching and also demonstrate in the lab how various components can be connected.
- Explain to students that ‘Curie temperature’ is that at which a ferromagnetic material becomes paramagnetic. ‘Curie’ is a unit of radioactivity and has nothing to do with Curie temperature which is a property of ferromagnetic substance. Ensure that there is no confusion.

### MARKING SCHEME

#### Question 5.

(a)

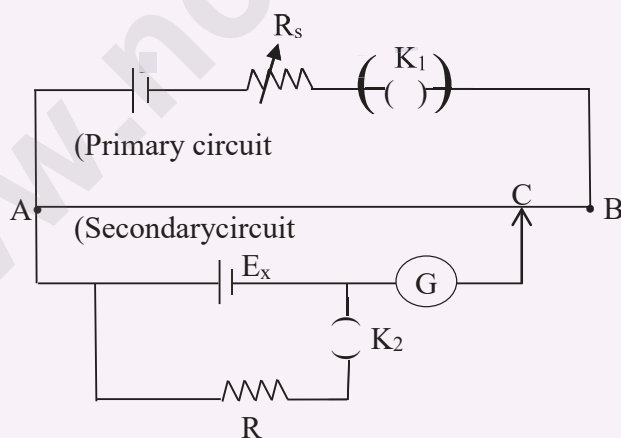

Working formula: *any one of the following:*

$$r = R \left( \frac{l_1}{l_2} - 1 \right) \quad \text{OR}$$

$$r = R \left( \frac{l_1 - l_2}{l_2} \right) \quad \text{OR}$$

$$r = R \left( \frac{l - l'}{l'} \right)$$

(b)	(i)	It is that temperature at which a ferromagnetic material becomes paramagnetic. OR That temperature at which its magnetic susceptibility becomes slightly greater than zero.
	(ii)	$\mu_r = 1 + x$ OR $\mu_r = 1 + 0.0001$ $= 1.0001$

**Question 6**

- (a) (i) Two infinitely long current carrying conductors X and Y are kept parallel to each other, 24 cm apart in vacuum. They carry currents of 5A and 7A respectively, in the **same** direction, as shown in **Figure 5** below. Find the position of a *neutral point*, i.e. a point where resultant magnetic flux density is zero. (Ignore earth's magnetic field). [3]

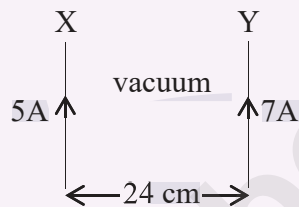

**Figure 5**

- (ii) If current through the conductor Y is **reversed** in direction, will neutral point lie between X and Y, to the left of X or to the right of Y?
- (b) (i) Define **Ampere** in terms of force between two current carrying conductors. [2]
- (ii) What is an **ideal** transformer?

Comments of Examiners

- (a)(i) A number of candidates used wrong formula for B. Some candidates did not know/use the fact that at neutral point,  $B_1=B_2$ . A few did not write the unit of or wrote it incorrectly. Some wrote  $r = 10$  and a few wrote  $r = 10\text{m}$ , instead of  $r = 10\text{ cm}$ .
- (ii) Some candidates answered this part incorrectly.
- (b)(i) Most of the candidates could not write the correct and complete definition of ‘Ampere’. They left out one or more of the following:
- Two current carrying conductors are long conductors.
  - They are kept parallel to each other.
  - They are kept in vacuum.
  - They are kept 1m apart.
  - Force between them is  $2 \times 10^{-7}\text{ N/m}$ .
- (ii) Most of the candidates could answer this question, though a few candidates wrote it is:
- that transformer in which  $e_s = e_p$  }
  - that transformer in which  $n_s = n_p$  }

Suggestions for teachers

- Explain to students that Neutral point is that when two or more magnetic fields (or electric fields) neutralise each other. Two magnetic fields produce a neutral point when  $B_1 = B_2$  and are in opposite directions. In case of like currents, it lies between them. In case of unlike currents, it lies outside, but it always lies near a weaker current carrying conductor. Ask students to understand and learn the definition of ‘Ampere’.
- Explain to students that an ideal transformer, like an ideal machine is that whose efficiency is 1 or 100%. So, there is no emergency loss or power loss. Output power = Input power.

**MARKING SCHEME**

**Question 6.**

(a)	(i)	$\{B_1 = B_2\}$ $\left\{ \left( \frac{\mu_0}{4\pi} \right) \frac{2I_1}{x} = \left( \frac{\mu_0}{4\pi} \right) \frac{2I_2}{(24-x)} \right\}$ $10^{-7} \times \frac{2 \times 5}{x} = \frac{10^{-7} \times 2 \times 7}{(24-x)}$ $7x = 120 - 5x$ $12x = 120$ $x = 10\text{ cm}$ <p>i.e. neutral point lies at a distance of 10 cm from the conductor X <b>or</b> 14 cm from the conductor Y.</p> <p>Note: Neutral point lies between X and Y.</p> <p><b><u>Alternate method:</u></b></p> <p>If a pupil calculates <math>B_1</math> using:</p> $B_1 = \frac{\mu_0}{4\pi} \times \frac{2I_1}{x}$
-----	-----	--

		$= 10^{-7} \times \frac{2 \times 7}{x}$ $= \frac{1 \times 10^{-6}}{x} \quad \text{and}$ $B_2 = \frac{\mu_0}{4\pi} \cdot \frac{2I_2}{(0.24-x)}$ $= 10^{-7} \times \frac{2 \times 7}{(0.24-x)}$ $= \frac{14 \times 10^{-7}}{(0.24-x)}$
	(ii)	<p>It will lie to the left of X (Neutral point always lies near a weaker current).</p>
(b)	(i)	<p>It is that current which while flowing through two (thin) (infinitely) long current carrying conductors kept parallel to each other 1m apart in vacuum, attract or repel each other with <math>2 \times 10^{-7} \text{ N(m}^{-1}\text{)}</math>.</p> <p>(i) Two conductors are kept parallel to each other.  (ii) Two conductors are kept 1 m apart  (iii) Two conductors are kept in vacuum  (iv) They attract or repel each other with <math>2 \times 10^{-7} \text{ N(m}^{-1}\text{)}</math>.</p> <p>A labelled diagram indicating at least three of the above said (four) may be accepted as an answer.</p> <div style="text-align: center;"> <p style="text-align: center;"> <math>F = 2 \times 10^{-7} \text{ N(m}^{-1}\text{)}</math> </p> </div>
	(ii)	<p>It is that in which there is no loss of any power. OR  It is that where output power = input power. OR  It is that whose efficiency is 1. OR  It is that in which electric power across secondary is equal to electric power across primary.</p>

### Question 7

- (a) A coil having **self-inductance** of  $0.7\text{H}$  and resistance of  $165\Omega$  is connected to an a.c. source of  $275\text{V}$ ,  $50\text{Hz}$ . If  $\pi = \frac{22}{7}$ , [3]
- Calculate:
- Reactance of the coil
  - Impedance of the coil
  - Current flowing through the coil
- (b) Draw a labelled graph showing variation of **impedance** of a series LCR circuit with frequency of the a.c. supply. [2]

### Comments of Examiners

- (a)(i) Some candidates used wrong formula of  $X_L$ . Instead of using  $X_L = 2\pi fL$ , they used  $X_L = \frac{1}{2\pi fL}$ ; Some did not give the unit, along with the answer.
- (ii) A few candidates got confused between reactance and impedance. They used formula  $Z = 2\pi fL$ . Some candidates did not substitute the values correctly in the formula  $Z = \sqrt{x_L^2 + R^2}$ . A few of them did not write the unit of  $Z$  i.e. Ohm.
- (iii) Several candidates used the wrong formula of current i.e.  $I = \frac{V}{R}$  instead of  $I = \frac{V}{Z}$ . In a few cases, the unit of  $I$  i.e. ampere was not written.
- (b) In a number of cases, phasor diagram was given in place of impedance-frequency curve. In some cases, the axes were not labelled or inter changed / wrong shape was given.

### Suggestions for teachers

- When alternating potential (ac. voltage) is applied to an inductor, the latter offers resistance to the flow of current which is called “reactance”. Thus, reactance is just like resistance. So, its units is Ohm ( $\Omega$ ). Reactance of an inductor ( $X_L$ ) =  $2\pi fL$  Should be proved (i.e derived). Also tell students that  $X_L$  varies directly with the frequency of the supply.
- Explain to students that the word / term Impedance comes from the verb: to impede (means to obstruct, to oppose, to resist etc). So, impedance is also like resistance. Hence, its unit is also (ohm). Impedance of an LR circuit depends on both  $L$  &  $R$  and frequency of supply.
- Current in a circuit depends on total resistance i.e impedance offered by the circuit, not on resistance alone. So,  $I = V/z$  and not  $V/R$ . SI Unit of current is ampere which is now taken as a standard fundamental unit like metre, kilogram and second.

**MARKING SCHEME**

**Question 7.**

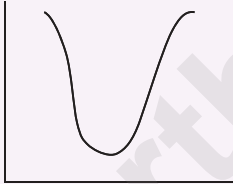
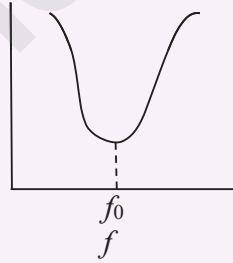
(a)	(i)	$(X_L) = (2\pi fL)/$ $= 2 \times \frac{22}{7} \times 50 \times 0.7$ $= 220 \Omega \text{ or } 219.8 \Omega$
	(ii)	$(z) = (\sqrt{X_L^2 + R^2})$ $= \sqrt{(220)^2 + (165)^2}$ $= 275\Omega \text{ or } 274.8 \Omega$
	(iii)	$(I) = \left(\frac{V_T}{z}\right)$ $= \frac{275}{275}$ $= 1A$
(b)	(i)	<p>Correct shape</p>  <p>(ii) Correct labelling, i.e. z on Y axis,  f on X axis and  (Resonant frequency) <math>f_0</math> marked on X axis as follows:</p>  <p style="text-align: right;">} <i>Any two</i></p>

## SECTION B

Answer any **three** questions.

### Question 8

- (a) Derive **Snell's law** of refraction using **Huygen's wave theory**. [3]
- (b) Monochromatic light of wavelength 650nm falls normally on a slit of width  $1.3 \times 10^{-4}$  cm and the resulting **Fraunhofer diffraction** is obtained on a screen. Find the **angular width** of the central maxima. [2]

#### Comments of Examiners

- (a) A few candidates proved the law of reflection (i.e.  $r = i$ ) instead of Snell's Law. A few of them wrote both the derivations as they were not sure, which derivation was required. The diagram was not given/drawn by some candidates. In some cases, incomplete diagram was given:
- Arrows were not given to incident rays/refracted rays.
  - Angles  $i$  and  $r$  was not shown or wrongly show.
  - Wave fronts were not stated Triangles were not mentioned while finding  $\sin i$  and  $\sin r$ .  $\sin i$  and  $\sin r$  were not found correctly. Some candidates drew wrong diagrams i.e. refraction wasn't shown correctly.
- (b) Many candidates assumed  $\theta$  to be very small (though  $\theta$  was unknown) and hence used a wrong formula  $\theta = \frac{\lambda}{a}$ , instead  $\sin \theta = \frac{\lambda}{a}$ . Hence they got wrong answer. Some did not write the unit - degree or radian. Others did not find angular width =  $2\theta$  - they thought  $\theta$  is the angular width.

#### Suggestions for teachers

- Train students to draw correct and labelled diagrams. Wave fronts must be marked correctly. A ray is perpendicular to the wave front. Angles  $i$  and  $r$  must be marked correctly. Media – rarer and denser and the speeds  $c$  and  $v$  or  $v_1$  &  $v_2$  must be written.
- Draw diagrams yourself, step by step explaining to students the importance of labelling..
- Show and explain to students: What is angular width of central maxima. It is  $= 2\theta$  where,  $\theta$  is given by  $\sin \theta = \frac{\lambda}{a}$ . Tell them, not to assume,  $\theta$  to be small, unless it is given, less than  $4^\circ$ . Also tell them that angle has a unit degree or radian. They must not forget to write the correct unit, along with the answer.

**MARKING SCHEME**

**Question 8.**

- (a) Correct diagram with  $i$  and  $r$  shown correctly with an arrow on either incident ray or refracted ray or incident wavefront and refracted wavefront mentioned in the diagram or the text.

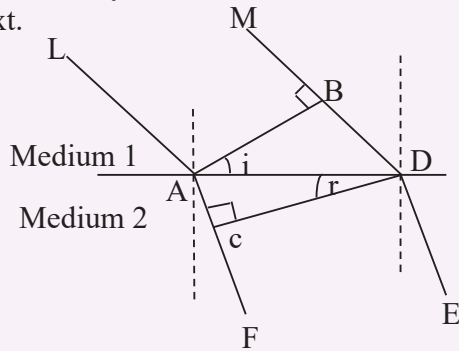

AB: Incident wavefront } OR an arrow on LA or MB or AF or DE  
 CD: Refracted wavefront }

$$\sin i = \frac{BD}{AD} \text{ and } \sin r = \frac{AC}{AD} \quad (v_1, v_2 \text{ acceptable in place of } c \text{ \& } v)$$

$$\frac{\sin i}{\sin r} = \frac{BD}{AC} = \frac{ct}{vt} = \frac{c}{v} = \text{constant} = \mu \text{ or } n$$

Alternate method:

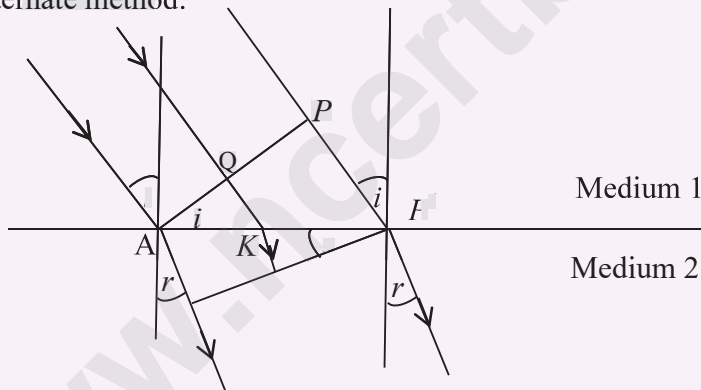

- (i) Correct diagram (as above)  
 (ii) Correct expression for  $t$ , i.e.

$$t = \frac{AP^1}{v} \sin r + AK \left( \frac{\sin i}{c} - \frac{\sin r}{v} \right)$$

(iii)  $\frac{\sin i}{\sin r} = \frac{c}{v} = \text{Constant}$

- (b)  $\sin \theta = \left( \frac{\lambda}{a} \right)$   
 $= \frac{650 \times 10^{-9}(m)}{1.3 \times 10^{-6}(m)}$  OR  $\frac{650 \times 10^{-7}(cm)}{1.3 \times 10^{-4}(cm)}$   
 $= 0.5$   
 $\therefore \theta = 30^\circ$   
 Angular width  $= (2 \theta) = 60^\circ$

**Question 9**

(a) In Young's double slit experiment, show that:

[4]

$$\beta = \frac{\lambda D}{d},$$

where the terms have their usual meaning.

(b) A ray of ordinary light is travelling in air. It is incident on air glass pair at a polarising angle of  $56^\circ$ . Find the angle of refraction in glass.

[1]

Comments of Examiners

- (a) Incorrect diagrams were drawn by a number of candidates. In some cases, labeling was not done or was incomplete/incorrect. Many candidates found  $\sin\theta$  and  $\tan\theta$  without marking  $\theta$  in the diagram. Steps were missing in the derivation. In several cases, the condition that path difference =  $m\lambda$ , was not used while deriving  $x = \frac{\lambda d}{d}$ . Some just wrote down the relation  $\beta = \frac{\lambda d}{d}$  without proving it.
- (b) Some candidates used a long and tedious method to obtain  $r$ , as they were not aware of the relation  $\theta_p + r = 90^\circ$ .

Suggestions for teachers

- Tell students that a correct and completely labelled diagram is essential for any derivation.
- Ask students to practice drawing diagrams and learn derivations, with understanding.
- Tell students and show that when ordinary light is incident at polarising angle, not only is the reflected light completely polarized but reflected rays are perpendicular to each other. So,  $\theta_p + r = 90^\circ$ .

**MARKING SCHEME**

**Question 9.**

(a)

**Method 1:**

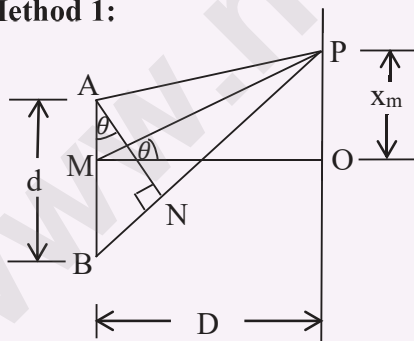

Correct diagram (as above)

$$\left. \begin{aligned} \sin \theta &= \frac{BN}{AB} = \frac{m\lambda}{d} \\ \text{and} \\ \tan \theta &= \frac{OP}{OM} = \frac{x_m}{D} \end{aligned} \right\}$$

$\therefore \theta$  is small,  
 $\tan \theta = \sin \theta$

	$\frac{x_m}{D} = \frac{m\lambda}{d}$ $\therefore x_m = \frac{m\lambda D}{d}$ <p>By putting <math>m = 1</math>, we get,</p> $x_1 = \frac{\lambda}{d} D$ <p>i.e. <math>\beta = \frac{\lambda}{d} D</math></p> <p><b>Method 2:</b></p> <p>(i) Correct diagram (same as above)</p> <p>(ii) <math>BP^2 - AP^2 = (x_m + \frac{d}{2})^2 - (x_m - \frac{d}{2})^2</math>  <math>= 2 x_m \cdot d</math>  <math>\therefore BP - AP = \frac{x_m \cdot d}{D}</math></p> <p>(iii) <math>m\lambda = \frac{x_m \cdot d}{D}</math>  i.e. <math>x_m = \frac{m\lambda D}{d}</math></p> <p>(iv) By putting <math>m = 1</math>, we get  <math>\lambda D</math></p>
(b)	<p>At polarising angle, reflected ray and refracted ray are perpendicular to each other.</p> $56 + r = 90^\circ \text{ and}$ $\therefore r = 90 - 56 = 34^\circ$

**Question 10**

- (a) Find the **angle of incidence** at which a ray of monochromatic light should be incident on the **first surface** AB of a **regular** glass prism ABC so that the emergent ray **grazes** the adjacent surface AC. (Refractive Index of glass = 1.56). [3]
- (b) State how focal length of a glass lens (Refractive Index 1.5) changes when it is completely immersed in: [2]
- (i) Water (Refractive Index 1.33)
- (ii) A liquid (Refractive Index 1.65)

### Comments of Examiners

- (a) A few candidates thought it to be a case of minimum deviation. Hence they found out  $\delta m$  and used  $i = \frac{A + \delta m}{2}$  leading to a wrong answer. Many candidates found out critical angle  $\theta_c$  and thought that was the correct and final answer. They could not find  $r_1$  and hence  $i$ . Some candidates did not understand the statement: 'grazing emergence'.
- (b) (i) Many candidates made lengthy calculations, which were not required. In some cases, incorrect formula was used to find the change in focal length.
- (ii) Many candidates wrote that focal length increases which is incorrect. They used wrong/incorrect formula to determine the new focal length.

### Suggestions for teachers

- Solve a few numericals, involving not only minimum deviation case, but other cases as well. Ask students to draw diagrams, while trying to solve numericals. They should themselves, solve as many numericals, as possible.
- Train students to read given questions carefully and answer accordingly to the question only. Spending a little more time on reading the question is more important than reading the question hurriedly and writing a wrong answer which fetches no marks.
- Solve a few problems based on lens maker's formula and tell students what happens when the lens is immersed in (a) a rarer medium and (b) a denser medium. In the former case, focal length of the lens increases whereas in latter case nature of the lens changes - Convex lens behaves like a concave lens and vice versa.

### MARKING SCHEME

#### Question 10.

(a)

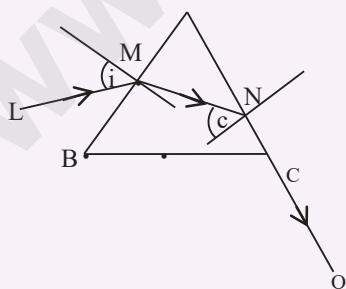

$$\sin c = \frac{1}{\mu} = \frac{1}{1.56}$$

$$\therefore c = 39.9^\circ \text{ or } 39.868^\circ \text{ or } 39.87^\circ \text{ or } 40^\circ$$

$$\therefore (r_1 + r_2 = A)$$

	$r_1 + 39.9^\circ = 60^\circ$ $\therefore r_1 = 20.1^\circ \text{ or } 20.13^\circ \text{ or } 20.13^\circ \text{ or } 20^\circ$ $\left(\frac{\sin i}{\sin r_1}\right) = \frac{\sin i}{\sin 20.1} = 1.56$ $\therefore \sin i = 1.56 \times \sin (20.1^\circ)$ $= 0.5361$ $\therefore i = 32.4^\circ \text{ in range } 32.2^\circ \text{ to } 32.5^\circ$
(b)	(i) Focal length of the lens increases.
	(ii) Focal length of the lens becomes –ve OR The convex lens behaves like a diverging lens and vice versa. Nature of lens changes.

**Question 11** sign convention was used by many

- (a) A convex lens of a focal length 5 cm is used as a **simple microscope**. Where should an object be placed so that the image formed by it lies at the least distance of distinct vision ( $D=25\text{cm}$ )? [2]
- (b) Draw a labelled ray diagram showing the formation of an image by a refracting **telescope** when the final image lies at infinity. [3]

#### Comments of Examiners

- (a) Incorrect use of sign convention by many candidates, leading to incorrect answers. In some cases, the answers were left in fraction/ unit was not given/ the answer was not rounded off correctly. In several cases, real image was considered, in place of virtual image. Some candidates took image at infinity, instead of least distance of distinct vision i.e.  $D = 25\text{cm}$ . Some candidates found  $M = 1 + \frac{D}{f}$  correctly but did not proceed further.
- (b) Most of the candidates could not draw correct labeled ray diagram of an astronomical telescope. Common errors were made by candidates were:
- Object not taken at infinity;
  - Image not formed at infinity;
  - Arrows not put to incident rays or emergent rays or both;
  - $F_o$  and  $F_e$  not coinciding;
  - Incomplete labeling: Object, eyepiece not labeled.  $F_o$ ,  $F_e$  not marked.

#### Suggestions for teachers

- Explain to students that a simple microscope is nothing but a convex lens having small focal length. It forms a virtual, erect and magnified image lying at  $D$  (or  $\infty$ ). So, a problem of simple microscope is a problem of convex lens. Hence they should use a lens formula with correct sign convention.
- Explain to students the correct sign convention with the help of numericals. Tell them to write the answer in decimal form, up to three significant figures, with correct unit.

- Draw the correct ray diagram on the board, step by step. Label the diagram completely, specially objective, eye piece, focal of objective ( $F_o$ ) and focus of eyepiece ( $F_e$ ). Tell students the importance of marking arrows - without arrows, they are mere straight lines and not the rays of light. Both incident rays and emergent rays are parallel, since both the object and the image are at infinity. Finally, ask students to practice these diagram again and again till they master them.

MARKING SCHEME	
<b>Question 11.</b>	
(a)	<p><b>Method 1:</b></p> <p>(Sign convention: Real is +ve Virtual is -ve)</p> $\left(\frac{1}{u} + \frac{1}{v} = \frac{1}{f}\right)$ $\frac{1}{u} + \frac{1}{-25} = \frac{1}{5} \dots\dots\dots [1]$ $\frac{1}{u} = \frac{1}{25} + \frac{1}{5}$ $\frac{1}{u} = \frac{6}{25}$ $u = \frac{25}{6}$ $u = 4.17 \text{ cm} \dots\dots\dots [1]$ $= 4.2 \text{ cm}$ <p><b>Method 2:</b></p> <p>(Cartesian co-ordinate system)</p> $\left(\frac{1}{v} - \frac{1}{u} = \frac{1}{f}\right)$ $\frac{1}{-25} - \frac{1}{u} = \frac{1}{5} \dots\dots\dots [1]$

$$\Rightarrow -\frac{1}{u} = \frac{1}{5} + \frac{1}{25}$$

$$\therefore u = -\frac{25}{6}$$

$$= -4.17 \text{ cm} \dots\dots\dots[1]$$

$$u = 4.2 \text{ cm}$$

**Method 3:**

$$M = 1 + \frac{D}{f}$$

$$= 1 + \frac{25}{5} = 6$$

$$\left( M = \frac{v}{u} \right)$$

$$6 = \frac{25}{u}$$

$$u = \frac{25}{6} = 4.2 \text{ cm}$$

- (b)
- (i) Correct incident rays (i.e. parallel and oblique) with an arrow on any one of them incident on 1<sup>st</sup> lens and inverted image formed.
  - (ii) Correct emergent rays (i.e. parallel and oblique) with an arrow on at least one of them with rays produced back.
  - (iii) F<sub>O</sub> & F<sub>e</sub> coinciding and either O or E marked in diagram.

## SECTION C

Answer any **three** questions.

### Question 12

- (a) Monochromatic light of wavelength 198 nm is incident on the surface of a metallic cathode whose work function is 2.5 eV. How much potential difference must be applied between the cathode and the anode of a photocell to **just stop** the photo current from flowing? [3]
- (b) (i) What is **de Broglie** hypothesis? [2]  
(ii) What conclusion can be drawn from **Davisson and Germer's** experiment?

### Comments of Examiners

- (a) Incorrect formula was used by many candidates/ substitution was done incorrectly. In some cases,  $nm$  was not converted to  $m$ , eV not converted to J. Wrong unit of stopping potential was given by a few candidates. Electron –volt (eV) was written in place of volt (V).
- (b)(i) Some candidates could not state de Broglie hypothesis correctly. 'Moving particles' – were not mentioned by some candidates. Some candidates wrote: light behaves like waves – not De Broglie hypothesis.  $\lambda = \frac{h}{p}$  was given by a few candidates but they did not mention that  $p$  is (linear) momentum.
- (ii) Some candidates wrote – waves behave like particles; others wrote: light has a dual nature. Several candidates did not know that Davisson Germer experiment was with moving electrons. A few described the experiment but did not write the conclusion drawn by them.

### Suggestions for teachers

- Explain Einstein's' photo electric equation i.e.  $E_{max} = \frac{hc}{\lambda} - \phi$  to students.
- Give them the relation between  $E_{max}$  & stopping potential  $V_s$  i.e.  $E_{max} = eV_s$ . Teach them how to convert nm to m and eV to J. Give them the unit of stopping potential i.e. volt (V).
- Tell students that all physical quantities must be in S.I. system, before substituting in an appropriate formula.
- State and explain De Broglie hypothesis to the students. Moving particles can behave like waves, not stationary particles. These wave are called "matter waves" and their wavelength  $\lambda$  depends on momentum ( $p$ ) of the particles like  $\lambda = \frac{h}{p}$
- Describe Davisson Germers' experiment along with its results.

**MARKING SCHEME****Question 12.**

(a)

**Method 1:**

Correct formula

$$eV_s = \frac{hc}{\lambda} - \phi \quad (w, \phi_0 \text{ or } E_0 \text{ acceptable in place of } \phi)$$

**OR**

$$V_{(s)} = \frac{hc}{e\lambda} - \frac{\phi}{e}$$

Correct substitution

With  $\lambda$  in m and $eV \rightarrow J$ 

correct answer with unit

i.e.  $V_s = 3.75V$

**OR****Method 2:**

$$(i) \quad E = \frac{hc}{\lambda} / \frac{6.6 \times 10^{34} \times 3 \times 10^8}{198 \times 10^{-9}}$$

$$E = 1 \times 10^{-18} \text{ J}$$

Or  $E = 6.25 \text{ eV}$

$$(ii) \quad E_{\max} = E - \phi$$

$$= 6.25 - 2.5$$

$$= 3.75 \text{ eV}$$

$$(iii) \quad eV_s = E - \phi$$

$$eV_s = 3.75 \text{ eV}$$

$$1.6 \times 10^{-19} V_s = 3.75 \times 1.6 \times 10^{-19}$$

$$\therefore V_s = 3.75V$$

**OR**

$$V_s = E_{\max} \text{ in eV} = 3.75V$$

(i) and (iii) may be combined

In combined form,

$$eV_s = E - \phi$$

$$= 6.25 - 2.5 = 3.75 \text{ eV}$$

$$\therefore V_s = 3.75V$$

(b)	(i)	It states that moving particles, electrons, etc. behave like waves or show wave nature or dual nature and their wavelength varies inversely with their momentum.  Or formula $\lambda = \frac{h}{p}$ where p is momentum  $= \frac{h}{mv}$
	(ii)	(Moving) electrons or particles can be diffracted <b>OR</b> (Moving) electrons or particles show wave nature <b>OR</b> (Moving) electrons or particles are behaving like waves. <b>OR</b> Dual nature of electrons/ particles <b>OR</b> Confirms De Broglie hypothesis

### Question 13

- (a) (i) How are various lines of **Lyman series** formed? Explain on the basis of **Bohr's theory**. [3]
- (ii) Calculate the **shortest** wavelength of electromagnetic radiation present in **Balmer** series of hydrogen spectrum.
- (b) State the effect of the following changes on the X-rays emitted by Coolidge X-ray tube: [2]
- (i) **High voltage between cathode and anode is increased.**
- (ii) Filament temperature is increased.

### Comments of Examiners

- (a)(i) Incorrect explanation for Lyman series was given by a number of candidates who wrote - transition from higher orbits to lower orbits instead of from higher orbits to 1<sup>st</sup> orbit. Some candidates wrote postulates of Bohr's Theory instead of writing the explanation. A few candidates wrote the general formula, not offering explanation of Lyman series.
- (ii) A number of candidates substituted  $n = 3$  in place of  $n = \infty$  in the formula  $\frac{1}{\lambda} = R \left( \frac{1}{2^2} - \frac{1}{n^2} \right)$ . Some candidates used wrong formula  $\frac{1}{\lambda} = R \left( \frac{1}{1^2} - \frac{1}{n^2} \right)$ . In several cases, the unit was not given along with the final answer

### Suggestions for teachers

- Explain to students, either with energy level diagram, or by drawing 7-8 orbits how various series of lines are formed in the hydrogen spectrum. Moreover, they should be told to write the answer, as per the question and not as a general essay.
- Solve numericals in class, based on Bohr's formula,  $\frac{1}{\lambda} = R \left( \frac{1}{n_f^2} - \frac{1}{n_i^2} \right)$  and show that  $n_i = 3$  will produce longest wavelength and  $n_i = \infty$  will produce minimum wavelength in Balmer series, for which  $n_f = 2$

- (b)(i) A few candidates wrote that quality of X rays changes; some wrote that intensity of X rays increases/ more X rays are produced.
- (ii) Candidates gave answers such as: More X-rays are produced/ more electrons are produced by the filament. They did not seem to have read the question carefully. A few candidates wrote that penetrating power increases - they seemed to be confused between intensity and penetrating power of X-rays.

- Explain step by step how (a) intensity of X-rays can be varied by varying the temperature of the filament i.e. by varying the current flowing through the filament and (b) penetrating power of emitted X-rays can be varied by varying high voltage (tube potential applied between cathode and anode. The former depends on number of electrons striking the target per second whereas the latter depends on the kinetic energy of the striking electrons.

MARKING SCHEME		
Question 13.		
(a)	(i)	<p>Various lines of Lyman series are obtained when electrons of hydrogen atom jump from higher orbits to the first orbit. <b>OR</b></p> <p>Hydrogen atom(s) go(es) from excited state(s) to the ground state. <b>OR</b></p> <p>A diagram showing e<sup>s</sup> going from higher orbits to the 1<sup>st</sup> orbit. <b>OR</b></p> <p>Energy level diagram showing downward transitions from higher levels to the lowest level (for which n = 1) or vice versa</p>
	(ii)	$\frac{1}{\lambda} = R \left( \frac{1}{2^2} - \frac{1}{n^2} \right)$ <p>With n = ∞ <b>OR</b></p> $\frac{1}{\lambda} = R \left( \frac{1}{2^2} \right)$ <p>Correct result</p> $\lambda = 3.646 \times 10^{-7} \text{m} \text{ or in equivalent unit}$
(b)	(i)	<p>More penetrating X-rays are obtained <b>or</b></p> <p>Penetrating power of emitted X-rays increases</p> <p>Or higher frequency X-rays are produced</p> <p>More energetic X-rays are emitted, OR</p> <p>Harder X-rays are obtained/emitted.</p>
	(ii)	<p>Intensity of emitted X-rays increases.</p> <p>Number of X- ray photons/sec increases</p>

### Question 14

- (a) **Half life** of a certain **radioactive material** is 8 hours. [3]
- (i) Find **disintegration constant** of this material.
- (ii) If one starts with 600g of this substance, how much of it will **disintegrate** in one day?
- (b) Sketch a graph showing the variation of **binding energy per nucleon** of a nucleus with its **mass number**. [2]

#### Comments of Examiners

- (a) (i) A few candidates did not write the unit of (disintegration constant). Some candidates used the wrong formula/ did wrong substitution and hence got wrong result. Rounding off was improper in a few cases.
- (ii) Many candidates got confused between mass of radioactive substance left behind and the mass disintegrated. Some forgot to write the unit along with final answer.
- (b) Some candidates forgot to label the axes. In some cases, the shape of the graph was incorrect. Some wrote: B.E. on Y-axis in place of B.E. per nucleon. A few candidates wrote atomic number, atomic mass, etc. on X-axis, in place of mass number.

#### Suggestions for teachers

- After deriving the relation between half-life (T) and disintegration constant, solve one or two numericals, specially taking T in different units like hours, day, years and give students the corresponding unit of  $\lambda$ . Students must be trained to correctly round up the answer, preferably upto 3 significant figures.
- The ladder  $N_0 \xrightarrow{T} \frac{1}{2}N_0 \xrightarrow{2T} \frac{1}{4}N_0 \xrightarrow{3T} \frac{1}{8}N_0$  etc. gives us the amount of radioactive substance left behind. Make this very clear to students. Amount disintegrated is then given by  $N_0 - \frac{1}{8}N_0 = \frac{7}{8}N_0$  etc. Make them practice such numericals by giving them different values of time (t) and half life (T).
- Give more practice in making graphs, with axes properly labelled.

#### MARKING SCHEME

##### Question 14.

(a)	(i)	$\lambda = \left(\frac{0.693}{T}\right)$ $= \frac{0.693}{8}$ $= 0.0866 \text{ per hour}$
		$\lambda = \frac{0.693}{8 \times 3600}$

OR

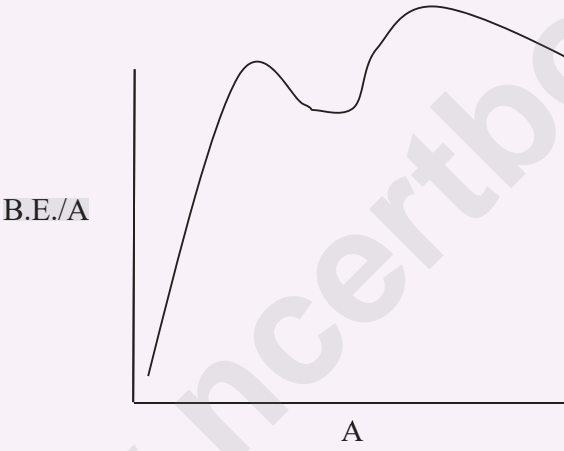
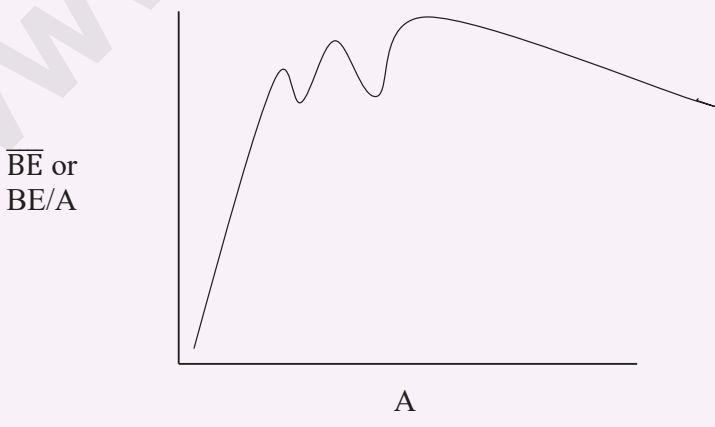
		$= 2.4 \times 10^{-5}$ per second.
	(ii)	<p>1 day = 24 hrs</p> <p>= 3 T</p> <p><math>600 \text{ g} \xrightarrow{T} 300 \text{ g} \xrightarrow{2T} 150 \text{ g} \xrightarrow{3T} 75 \text{ g}</math> left</p> <p>Amount disintegrated = (600 - 75)</p> <p>= 525 g</p> <p>(Other formulae also applicable.)</p>
(b)	(i)	Approximately correct shape
	(ii)	Correct labelling i.e. B.E./A on Y axis and A on X axis
		 <p>OR</p> 

### Question 15

(a) Draw a circuit diagram for the **common emitter transistor amplifier**. What is meant by **phase reversal**? [3]

(b) Write the **truth table** of the following circuit. Name the **gate** represented by this circuit. [2]

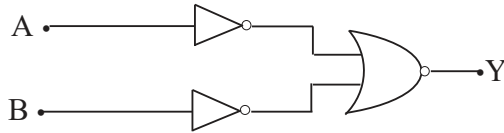

### Comments of Examiners

- (a) Some common errors made by candidates in this part were:
- Wrong symbol of transistor given
  - a c. input not shown.
  - Incorrect biasing shown.
  - Output or load or  $R_L$  not shown.
  - A few candidates could not draw the correct circuit of an amplifier.
  - Some candidates drew the circuit of “characteristic curves” of a transistor, rather than an amplifier.
  - Some candidates did not define phase reversal correctly or show it on the diagram.
- (b) A number of candidates could not make correct the truth table for the given combination of gates. Hence, they could not judge which gate it represents. A number of candidates gave only 2-3 sets of input & output, instead of four. A few candidates wrote the answer as “and” or “And”, in place of “AND”.

### Suggestions for teachers

- Make students practice the symbols of semiconductor diodes, transistors, etc. Draw the circuit of an amplifier, step by step, explaining to them, various components, like batteries, specially how they are connected and why. Make students practice the diagram with correct labelling.
- Teach the basic gates, AND, OR & NOT gates, their meaning, roles, symbols and truth table. Then introduce NAND gate and NOR gates the Universal gate. Teach students how to make Truth Table for different combinations of gates and what gate each combination represents.
- Also explain to students how various basic gates can be obtained starting with NAND OR NOR gates.

**MARKING SCHEME**

**Question 15.**

(a) (Either PNP OR NPN transistor may be used by a pupil.)

(i)

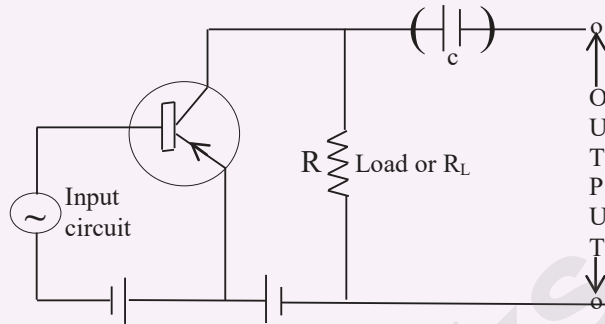

Correct input circuit

Correct output circuit

Signal, grid bias and correct collector battery & load or output

(ii) When signal voltage is positive,

Output is -ve and

When signal voltage is -ve

Output is +ve.

This is called phase reversal.

OR

Input and output voltages are out of phase by  $180^\circ$  or  $\pi$  rad

OR Correct diagram.

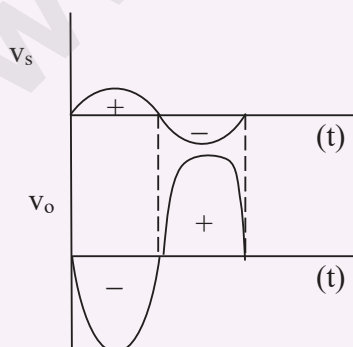

(b)	<table border="1" style="margin: auto;"> <thead> <tr> <th>A</th> <th>B</th> <th>(1)</th> <th>(2)</th> <th>Y</th> </tr> </thead> <tbody> <tr> <td>0</td> <td>0</td> <td>1</td> <td>1</td> <td>0</td> </tr> <tr> <td>0</td> <td>1</td> <td>1</td> <td>0</td> <td>0</td> </tr> <tr> <td>1</td> <td>0</td> <td>0</td> <td>1</td> <td>0</td> </tr> <tr> <td>1</td> <td>1</td> <td>0</td> <td>0</td> <td>1</td> </tr> </tbody> </table>					A	B	(1)	(2)	Y	0	0	1	1	0	0	1	1	0	0	1	0	0	1	0	1	1	0	0	1
A	B	(1)	(2)	Y																										
0	0	1	1	0																										
0	1	1	0	0																										
1	0	0	1	0																										
1	1	0	0	1																										
	It represents AND gate OR symbol of AND gate.																													

### GENERAL COMMENTS

#### (a) Topics found difficult by candidates in the Question paper:

- Intensity of electric field due to two point charges.
- Internal resistance of a cell by potentiometer.
- Kirchoffs' Law.
- Neutral point due to two long current carrying conductors.
- Labelled ray diagram of an astronomical telescope.
- Range of wavelengths in an electromagnetic spectrum.
- Colour coding of carbon resistors.
- Einstein's photo electric equation.
- Bohr's theory of spectrum of hydrogen
- Common emitter amplifier.
- Refraction of light through a prism.
- Width of central Maxima in Fraunhofer diffraction.

#### (b) Concepts between which candidates got confused:

- Shortsightedness and Long sightedness.
- Polarised light and unpolarised light.
- Refraction of light and reflection of light based on Huygen's wave theory.
- Ray diagram of astronomical telescope and compound microscope.
- Potentiometer and Wheatstone bridge.
- Conversion of Galvanometer into ammeter and voltmeter.
- Curie temperature and Curie's Law
- Capacitors in series and parallel.
- Graph of Z vs f and phasors.
- Shortest and longest wavelength of Balmer series.

- Circuit of an amplifier and that of obtaining characteristic curves of a transistor
- Function of a moderator and control rod in an atomic reactor
- Various logic gates and their truth tables.
- Sign convention in lenses.
- De Broglie hypothesis & Davisson Germer's experiment.
- Reactance and impedance of a series LCR Circuit.

**(c) Suggestions for candidates:**

- Study all topics regularly.
- Prepare a list of formulae in each branch of physics and learn them by heart, with meaning of each and every term/symbol.
- Practice solving numericals at home.
- Practice drawing and labelling diagrams (ray diagrams, circuit diagrams) figures, graphs etc.
- Learn various laws, principles and key terms.
- Convert given data to SI system, before substitution.
- Solve Old ISC papers for practice.
- Read the question very carefully and answer to the point.
- In Part I, answer all questions in brief and to the point.
- While solving numerical, ensure that all quantities are in SI system. Write the relevant formula and substitute known quantities. Solve for the unknown. Write the answer with unit. Round up the result up to three significant figure. Do not leave the answer in fractions.
- In Ray optics, arrows must be given to the rays.
- While plotting graphs, axes must be labelled.
- Instead of trying to solve the entire paper, use the reading time effectively to select the best questions.
- Attempt sub questions of the same question in one place.
- Rough work, if any, should be done in the right hand margin, on same page, as rest of the answer.
- Use the values of constants as given at the end of the question paper.
- Be careful with numericals involving vector quantities. Remember their addition, subtraction and multiplications are different from those of scalars.