

ISC Paper 2017

Physics

Maximum Marks: 70

Time allowed: Three hours

- Candidates are allowed additional 15 minutes for only reading the paper. They must NOT start writing during this time
 - Answer all questions in Part I and ten questions from Part II, choosing four questions from
 - Section A, three questions from Section B and three questions from Section C.
 - All working, including rough work, should be done on the same sheet as, and adjacent to, the rest of the answer.
 - The intended marks for questions or parts of questions are given in brackets [].
 - Material to be supplied: Long tables including Trigonometric functions.
 - A list of useful physical constants is given at the end of this paper.
-

Part – I (20 Marks)

(Answer all questions)

Question 1.

(a) Choose the correct alternative (a), (b), (c) or (d) for each of the questions given below: [5]

(i) The electrostatic potential energy of two point charges, $1 \mu\text{C}$ each, placed 1 metre apart in air is :

- (a) $9 \times 10^3 \text{ J}$
- (b) $P \times 10^9 \text{ J}$
- (c) $9 \times 10^{-3} \text{ J}$
- (d) $9 \times 10^{-3} \text{ eV}$

(ii) A wire of resistance R' is cut into 'n' equal parts. These parts are then connected in parallel with each other. The equivalent resistance of the combination is :

- (a) nR
- (b) R/n
- (c) n/R^2
- (d) R/n^2

(iii) Magnetic susceptibility of platinum is 0.0001. Its relative permeability is :

- (a) 1.0000
- (b) 0.9999
- (c) 1.0001
- (d) 0

(iv) When a light wave travels from air to glass :

- (a) its wavelength decreases
- (b) its wavelength increases
- (c) there is no change in wavelength
- (d) its frequency decreases.

(v) A radioactive substance decays to 1/16th of its initial mass in 40 days. The half life of the substance, in days, is:

- (a) 20
- (b) 10
- (c) 5
- (d) 2.5

B. Answer all questions given below briefly and to the point: [15]

(i) Maximum torque acting on the electric dipole of moment 3×10^{-29} Cm in a uniform electric field E is 6×10^{-25} Nm. Find E.

(ii) What is meant by drift speed of free electrons ?

(iii) On which conservation principle is Kirchhoff's Second Law of electrical networks based ?

(iv) Calculate magnetic flux density of the magnetic field at the center of a circular coil of 50 turns, having radius of 0.5 m and carrying a current of 5 A. .

(v) An a.c. generator generates an emf 's' where $e = 314 \sin(50\pi t)$ volt. Calculate the frequency of the emf ϵ .

(vi) With what type of source of light are cylindrical wave fronts associated ?

(vii) How is fringe width of an interference pattern in Young's double slit experiment affected if the two slits are brought closer to each other ?

(viii) In a regular prism, what is the relation between angle of incidence and angle of emergence when it is in the minimum deviation position ?

(ix) A converging lens of focal length 40 cm is kept in contact with a diverging lens of focal length 30 cm. Find the focal length of the combination.

(x) How can the spherical aberration produced by a lens be minimised ?

(xi) Calculate the momentum of a photon of energy 6×10^{-19} J.

(xii) According to Bohr, Angular momentum of an orbiting electron is quantised. ' What is meant by this statement ?

(xiii) Why nuclear fusion reaction is also called thermo-nuclear reaction ?

(xiv) What is the minimum energy which a gamma ray photon must possess in order to

produce electron-positron pair ?

(xv) Show the variation of voltage with time, for a digital signal.

Answers:

A. (i) $(b) = [9 \times 10^9 \text{ J}]$

(ii) $(b) = [R/n]$

(iii) $(c) = [1.0001]$ Since $\mu_r = 1 + \psi$

(iv) $(a) [\because \lambda \propto v \text{ (frequency is constant)}]$

(v) $(c) [= 5]$

B. (i) $\vec{\tau} = \vec{p} \times \vec{E}$

$$\therefore \vec{E} = \frac{\tau}{p} [\because \theta = 90^\circ] = \frac{6 \times 10^{-25} \text{ Nm}}{3 \times 10^{-29} \text{ Cm}} = 2 \times 10^4 \text{ N C}^{-1}$$

(ii) The average of minimum and maximum velocity of free electron between consecutive collisions with positive ions is called drift velocity.

(iii) Kirchoff's Second Law states about law of conservation of energy.

(iv) $N = 50$ turns, Radius $r = 0.5$ m, Current $I = 5$ A

$$\begin{aligned} \therefore \text{Magnetic flux density at centre} = B &= \frac{\mu_0 NI}{2a} \\ &= \frac{4\pi \times 10^{-7} \times 50 \times 5}{2 \times 0.5} \text{ T} \\ &= 2\pi \times 10^{-7} \times 500 \text{ T} \\ B &= 3.14 \times 10^{-4} \text{ T} \end{aligned}$$

or

$$B = 10^{-4} \pi \text{ T}$$

(v) Since $e = 314 \sin 50 \pi t \text{ V}$

$$\therefore \omega = 50 \pi$$

$$\text{Hence, frequency, } f = \frac{50\pi}{2\pi} = 25 \text{ Hz or Rad s}^{-1}$$

(vi) Line source of light yields cylindrical wave front.

(vii) Fringe width, $\beta = \frac{\lambda D}{d}$

\therefore If d (= separation of slit) decreases, β will increase.

(viii) Angle of incidence = Angle of emergence in the case of minimum deviation

$$(ix) \frac{1}{F'} = \frac{1}{f_1} + \frac{1}{f_2} = \frac{1}{+40} + \frac{1}{-30} = \frac{1}{40} - \frac{1}{30}$$

$$\frac{1}{F'} = \frac{3-4}{120} = -\frac{1}{120} \text{ cm [Diverging]}$$

(x) In order to remove the spherical aberration, the central part of the lens is covered with an opaque object called stop.

(xi) Energy of photon, $E = p \times c$

$$6 \times 10^{-19} = p \times 3 \times 10^8$$

$$\therefore p = \frac{6 \times 10^{-19}}{3 \times 10^8} = 2 \times 10^{-27} \text{ N s}^{-1}$$

(xii) This means that electron revolves round the nucleus in fixed *i.e.*, quantised orbits and

do not radiate energy *i.e.*, angular momentum in these orbits is integral multiple of $\frac{h}{2\pi}$,

where h is Planck's constant.

(xiii) This is because it takes place only at high temperature. If the reacting nuclei are at high temperature, then they will have sufficient energy to overcome coulombian force.

(xiv) This is called pair production $\left(\begin{array}{c} \nu \rightarrow \\ \downarrow \\ \text{Energy} \end{array} \quad \underbrace{-1e^0 + +1e^0}_{\text{Mass particle}} \right)$. Here energy is transferred into

mass. The minimum energy is known as Binding energy = 93/MeV.

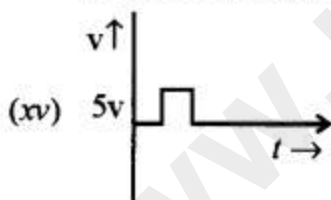

Part – II (20 Marks)

Answer ten questions in this part, choosing four questions from Section A, three questions from Section B and three questions from Section C

Section-A
(Answer any four questions)

Question 2.

(a) Show that electric potential at a point P, at a distance 'r' from a fixed point charge Q, is given by: [4]

$$V = \left(\frac{1}{4\pi\epsilon_0} \right) \frac{Q}{r}$$

(b) Intensity of electric field at a perpendicular distance of 0.5 m from an infinitely long line charge having linear charge density (λ) is $3.6 \times 10^3 \text{ Vm}^{-1}$. Find the value of λ . [1]

Answer:

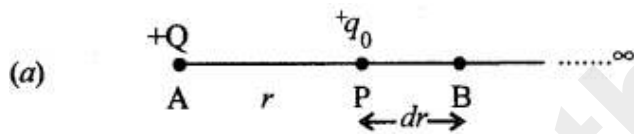

Let potential at point P is required due to a fixed point charge Q at A. Distance $\overline{AP} = r$. Let us place a point test charge q_0 at P. Let us consider a point B very near to P at a distance dr , such that $\overline{F_P} = \overline{F_B}$.

$$\text{Force, } \overline{F} \text{ between } Q \text{ and } q_0 = \frac{1}{4\pi\epsilon_0} \cdot \frac{Q \times q_0}{r^2}$$

where ϵ_0 = permittivity for free space

Now, work done in carrying the charge q_0 from P to B is

$$dW = - \frac{1}{4\pi\epsilon_0} \frac{Q \times q_0}{r^2} \cdot dr$$

Negative sign indicates negative work due to repulsion between Q and q_0 .

Similarly,

Work done in carrying to infinity (∞),

$$W = \int dW = - \int_r^{\infty} \frac{1}{4\pi\epsilon_0} \cdot \frac{Q \times q_0}{r^2} \cdot dr$$

$$\Rightarrow W = - \frac{1}{4\pi\epsilon_0} \cdot Q \times q_0 \int_r^{\infty} r^{-2} dr$$

$$\Rightarrow W = + \frac{1}{4\pi\epsilon_0} \cdot Q \times q_0 \left[\frac{1}{r} \right]_r^{\infty}$$

$$\Rightarrow W = + \frac{1}{4\pi\epsilon_0} \cdot Q \times q_0 \left[\frac{1}{\infty} - \frac{1}{r} \right]$$

$$\Rightarrow W = - \frac{1}{4\pi\epsilon_0} \cdot \frac{Q \times q_0}{r}$$

When, the test charge, q_0 is taken from ∞ .

The work done is positive and magnitude remains same.

$$\therefore W = \frac{1}{4\pi\epsilon_0} \cdot \frac{Q \times q_0}{r}$$

Since potential at P = $\frac{W}{q_0}$

$$\therefore V, \text{ potential at P} = \frac{1}{4\pi\epsilon_0} \cdot \frac{Q \times q_0}{r \cdot q_0}$$

$$V = \frac{Q}{4\pi\epsilon_0 r} \text{ J C}^{-1} \text{ or V}$$

$$V = \left(\frac{1}{4\pi\epsilon_0} \right) \cdot \frac{Q}{r} \text{ V}$$

(b) $\lambda = E \cdot 2\pi\epsilon_0 r$ where $E = 3.6 \times 10^3 \text{ Vm}^{-1}; r = 5 \text{ m}$

$$\therefore \lambda = 3.6 \times 10^3 \times 0.5 \times 2 \times 3.14 \times 8.85 \times 10^{-12}$$

$$= 3.6 \times 10^3 \times 3.14 \times 8.85 \times 10^{-12}$$

$$= 100 \times 10^{-9}$$

$$= 10^{-7} \text{ Cm}^{-1}$$

$$\therefore \lambda = 10^{-7} \text{ Cm}^{-1}$$

Question 3.

(a) Three capacitors $C_1 = 3 \mu\text{F}$, $C_2 = 6 \mu\text{F}$ and $C_3 = 10 \mu\text{F}$ are connected to a 50 V battery as shown in the Figure 1 below : [3]

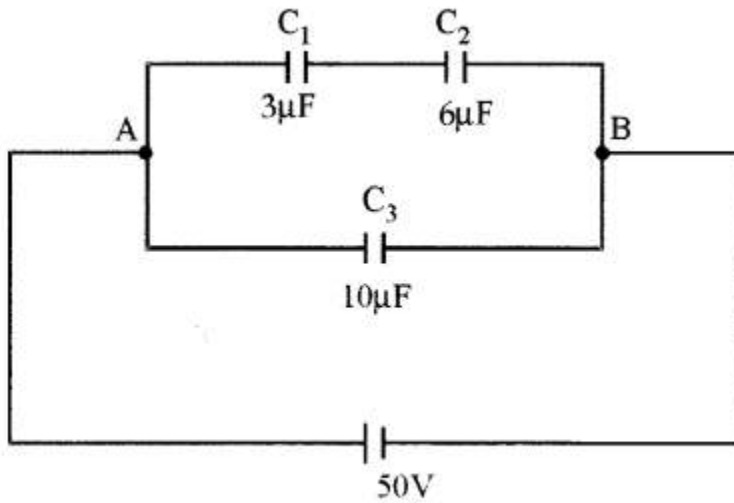

Figure 1

Calculate :

- (i) The equivalent capacitance of the circuit between points A and B.
 - (ii) The charge on C_1
- (b) Two resistors $R_1 = 60 \Omega$ and $R_2 = 90 \Omega$ are connected in parallel. If electric power consumed by the resistor R_1 is 15 W, calculate the power consumed by the resistor R_2 . [2]

Answer:

a) $C_1 = 3 \mu\text{F}$, $C_2 = 6 \mu\text{F}$, $C_3 = 10 \mu\text{F}$

If C' be in equivalent capacitance between C_1 and C_2 , then

$$\begin{aligned} \frac{1}{C'} &= \frac{1}{C_1} + \frac{1}{C_2} \\ &= \frac{1}{3} + \frac{1}{6} = \frac{2}{6} + \frac{1}{6} = \frac{3}{6} = \frac{1}{2} \\ C' &= 2\mu\text{F} \end{aligned}$$

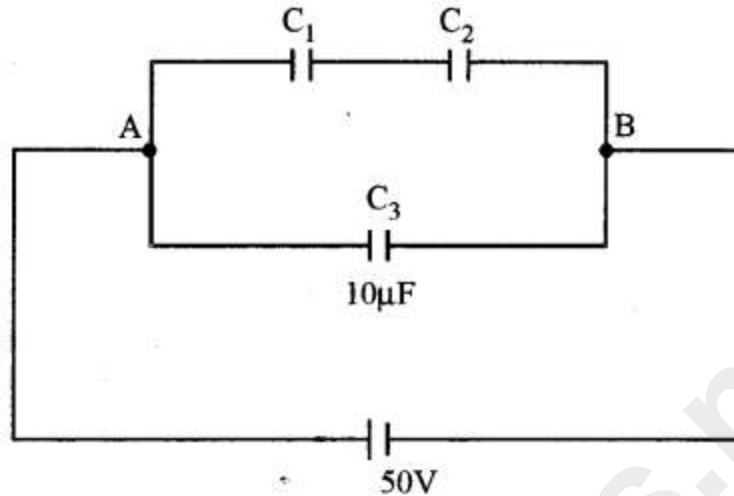

Now,

$$C_{Eq} = C' + C_3 = 2 + 10$$

$$C_{Eq} = 12 \mu\text{F}$$

(i) Eq. capacitance between A and B = $12 \mu\text{F}$

(ii) Charge at $C_1 = 2 \times 10^{-6} \times 50 \text{ C} = 10^{-4} \text{ C}$

(b)

$$\text{Power of } R_1 = \frac{V^2}{R_1}$$

\Rightarrow

$$15 = \frac{V^2}{60}$$

\Rightarrow

$$V^2 = 60 \times 15 = 900$$

\therefore

$$V = 30 \text{ V}$$

Hence, R_2 being parallel with R_1 , has same p.d.

\therefore

$$\text{Power of } R_2 = \frac{30 \times 30}{90} = 10 \text{ W.}$$

Question 4.

(a) Figure 2 below shows two resistors R_1 and R_2 connected to a battery having an emf of 40 V and negligible internal resistance. A voltmeter having a resistance of 300Ω is used to measure potential difference across R_1 . Find the reading of the voltmeter. [3]

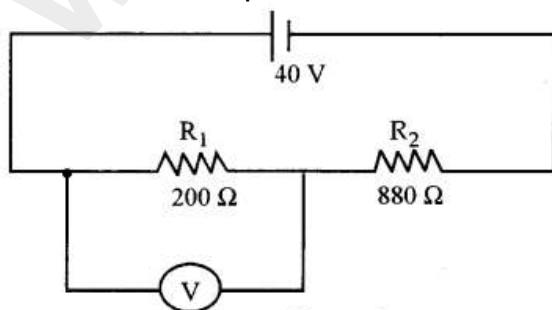

Figure 2

(b) A moving coil galvanometer has a coil of resistance 59Ω . It shows a full scale deflection for a current of 50 mA . How will you convert it to an ammeter having a range of 0 to 3A ? [2]

Answer:

(a) R_1 and R_3 are in parallel.

\therefore Current I in the circuit remains unchanged in R_1 and R_3 combination and R_2

$$\frac{1}{R'} = \frac{1}{200} + \frac{1}{300} = \frac{5}{600}$$

$$R' = \frac{600}{5} = 120 \Omega$$

$$\therefore R_{\text{Equivalent in circuit}} = 120 + 880 = 1000 \Omega$$

$$I, \text{ current in the circuit} = \frac{40}{1000} \text{ A}$$

$$\therefore V = \frac{40}{1000} \times 120$$

$$\Rightarrow V = \frac{48}{10}$$

$$\therefore V = 4.8 \text{ V}$$

(b) Let resistance of $R_s \Omega$ be shunted with galvanometer to make it an ammeter in parallel.
p.d. across the galvanometer = p.d. across the shunt

$$I_{C_1} \times R_{C_1} = (I - I_{C_1}) \cdot R_s$$

$$\Rightarrow R_s = \frac{I_{C_1} \cdot R_{C_1}}{(I - I_{C_1})} = \frac{50 \times 10^{-3} \times 59}{(3 - 50 \times 10^{-3})}$$

$$\Rightarrow R_s = \frac{50 \times 10^{-3} \times 59}{2.95} = \frac{50 \times 10^{-3} \times 10^2 \times 59}{295}$$

$$\therefore R_s = 1 \Omega$$

A resistance of 1Ω be required to shunt in order to convert this into ammeter.

Question 5.

(a) In a meter bridge circuit, resistance in the left hand gap is 2Ω and an unknown resistance X is in the right hand gap as shown in Figure 3 below. The null point is found to be 40 cm from the left end of the wire. What resistance should be connected to X so that the new null point is 50 cm from the left end of the wire ?

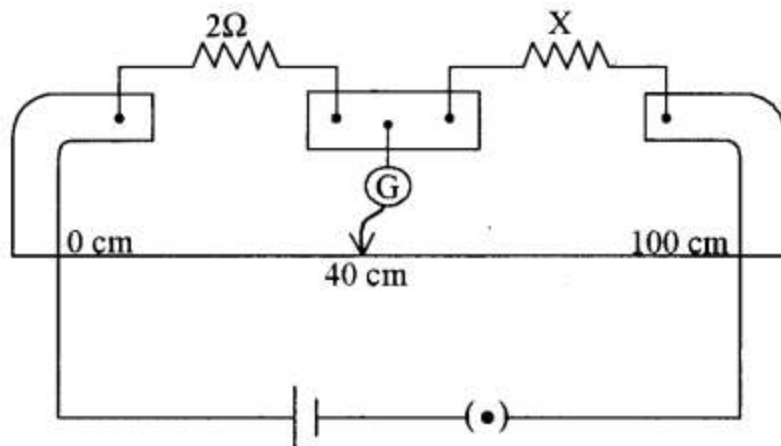

Figure 3

b) The horizontal component of earth's magnetic field at a place is $1/\sqrt{3}$ times the vertical component. Determine the angle of dip at that place.

Answer:

(a) According to the Fig. 3

$$\frac{2}{X} = \frac{40}{100 - 40} = \frac{4}{6}$$

$$X = 3 \Omega$$

Let $R \Omega$ be connected with X in parallel to obtain the null point at 50 cm from left.

Now, if $S \Omega$ be in equivalent resistance of X and R then,

$$\frac{2}{S} = \frac{50}{100 - 50} = 1$$

\therefore

$$S = 2 \Omega$$

Now, to obtain 2Ω as equivalent resistance between X and R , we have

$$\frac{1}{2} = \frac{1}{3} + \frac{1}{R}$$

\therefore

$$R = 6 \Omega$$

$\therefore 6 \Omega$ resistance is to be connected in parallel to X .

(b) Let angle of dip = θ , vertical component = V Tesla

\therefore

$$\tan \theta = \frac{V}{H} = \frac{V}{\frac{1}{\sqrt{3}}V} = \sqrt{3} = \tan 60^\circ$$

\therefore

$$\theta = 60^\circ$$

Question 6.

(a) Using Ampere's circuital law, obtain an expression for the magnetic flux density 'B' at a point X' at a perpendicular distance 'r' from a long current carrying conductor.

(Statement of the law is not required). [3]

(b) PQ is a long straight conductor carrying a current of 3A as shown in Figure 4 below. An electron moves with a velocity of $2 \times 10^7 \text{ ms}^{-1}$ parallel to it. Find the force acting on the electron.

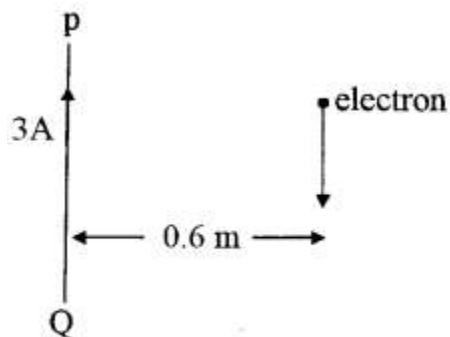
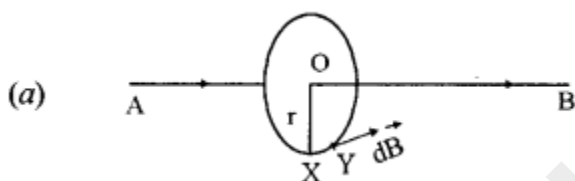

Figure 4

Answer:



Let AB, a long straight wire is carrying current i . The magnetic flux density \vec{B} is to be required at point X at a distance r .

Let us draw a circle of radius r with centre O as shown in above figure. The point X lies on the circumference of the circle.

According to Ampere's circuital law,

$$\oint \vec{B} \cdot d\vec{l} = \mu_0 i, \text{ where } d\vec{l} = \text{infinitesimally small portion XY in the circle.}$$

$$\text{For complete circle, } d\vec{l} = 2\pi r$$

$$\therefore \vec{B} \cdot 2\pi r = \mu_0 i$$

$$\Rightarrow \vec{B} = \frac{\mu_0}{2\pi} \cdot \frac{i}{r} \text{ NA}^{-1}\text{m}^{-1}$$

$$\Rightarrow \vec{B} = \frac{\mu_0}{4\pi} \cdot \frac{2i}{r}$$

$$\therefore \vec{B} = 10^{-7} \cdot \frac{2i}{r} \text{ NA}^{-1}\text{m}^{-1}$$

(b) $q = 1.6 \times 10^{-19} \text{ C}, i = 3 \text{ A}, r = 0.6 \text{ m}$

$$v = 2 \times 10^7 \text{ ms}^{-1}$$

$$\theta = 90^\circ$$

$$\vec{B} = 10^{-7} \times \frac{2 \times 3}{0.6}$$

$$\therefore \text{Force on electron, } \vec{F} = q v B \sin \theta$$

$$\vec{F} = 1.6 \times 10^{-19} \times 2 \times 10^7 \times 10^{-7} \cdot \frac{6}{0.6}$$

$$\vec{F} = 3.2 \times 10^{-18} \text{ N}$$

Question 7.

(a) (i) AB and CD are two parallel conductors kept 1 m apart and connected by a resistance R of 6Ω as shown in Figure 5 below. They are placed in a magnetic field $B = 3 \times 10^{-2} \text{ T}$ which is perpendicular to the plane of the conductors and directed into the paper. A wire MN is placed over AB and CD and then made to slide with a velocity 2 ms^{-1} . (Neglect the resistance of AB, CD, and MN). [3]

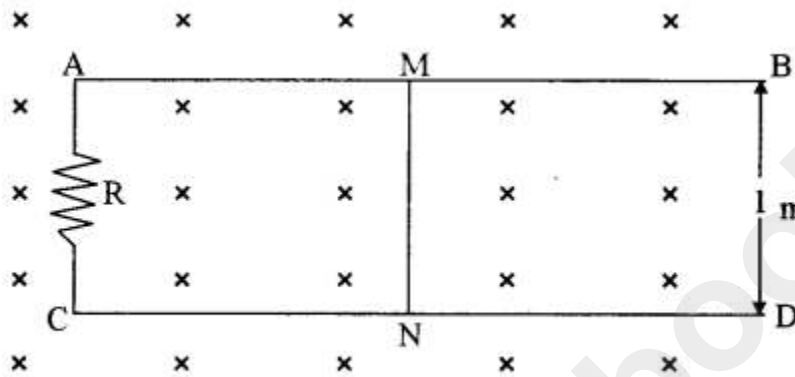

Figure 5

Calculate the induced current flowing through the resistor R.

- (ii) In an ideal transformer, an output of 66 kV is required when an input voltage of 220 V is available. If the primary has 300 turns, how many turns should the secondary have?
 (b) In a series LCR circuit, obtain an expression for the resonant frequency. [2]

Answer:

(a) (i) Let \vec{F} be the force on any free electron within the wire MN.

$$|\vec{F}| = q|\vec{v}||\vec{B}| \sin 90^\circ$$

$$\Rightarrow F = q \times 2 \times 3 \times 10^{-2}$$

Now, W, the work done = force \times displacement

$$W = F \times 1$$

$$W = q \times 2 \times 3 \times 10^{-2}$$

Potential difference or emf induced

$$= \frac{W}{q}$$

$$\Rightarrow e = \frac{q \times 6 \times 10^{-2}}{q} \text{ V}$$

$$e = 6 \times 10^{-2} \text{ V}$$

∴ Induced current in R(6Ω)

$$\begin{aligned} &= \frac{V}{R} = \frac{E}{R} \\ &= \frac{6 \times 10^{-2}}{6} = 10^{-2} \text{ A} \end{aligned}$$

∴ Current = $10^{-2} = .001 \text{ A}$

(ii) $E_p = 220 \text{ V}$
 $E_s = 66 \text{ kV} = 66 \times 10^3 \text{ V}$

$$N_p = 300$$

$$\frac{E_p}{E_s} = \frac{N_p}{N_s}$$

$N_s =$ Number of turn in secondary

$$\Rightarrow \frac{220}{66 \times 10^3} = \frac{300}{N_s} \qquad \Rightarrow N_s = 90000 \text{ turns}$$

(b) In a series LCR circuit,

$$I = \frac{E}{\sqrt{R^2 + \left(\omega L - \frac{1}{\omega C}\right)^2}}$$

From this equation, we may observe that when $\omega = 0$, I becomes 0, and again when

$$\omega = \infty, I = 0$$

∴ This implies there must be a value of ω at which I is maximum.

So when I is maximum, $\sqrt{R^2 + \left(\omega L - \frac{1}{\omega C}\right)^2}$ is minimum

For this either $R = 0$, or $\omega L - \frac{1}{\omega C} = 0$

So when $\omega L - \frac{1}{\omega C} = 0$, this is called resonance condition.

∴ At resonance,

$$\begin{aligned}\omega L &= \frac{1}{\omega C} \\ \Rightarrow \omega^2 &= \frac{1}{LC} \\ \Rightarrow \omega_r &= \frac{1}{\sqrt{LC}} \\ \Rightarrow 2\pi f_r &= \frac{1}{\sqrt{LC}} \\ \therefore f_r &= \text{Frequency of resonance} \\ &= \frac{1}{2\pi} \cdot \frac{1}{\sqrt{LC}} \\ \text{i.e., } f_r &= \frac{1}{2\pi} \cdot \frac{1}{\sqrt{LC}}\end{aligned}$$

This is the required expression for resonant frequency.

Section – B
(Answer any three questions)

Question 8.

- (a) (i) State any one property which is common to all electromagnetic waves. [3]
(ii) Arrange the following electromagnetic waves in increasing order of their frequencies (i.e., begin with the lowest frequency) :
Visible light, γ -rays, X-rays, microwaves, radio waves, infrared radiations and ultraviolet radiations.
- (b) (i) What is meant by diffraction of light ? [2]
(ii) In Fraunhofer diffraction, what kind of source of light is used and where is it situated?

Answers :

- (a) (i) Electromagnetic waves do not deflect in electric and magnetic fields.
(ii) Radio waves < micro waves < infrared < visible light < ultraviolet radiations < X-rays < γ -rays.
- (b) (i) When a light ray is obstructed by an object having the size of the order of the wavelength of the ray in its path, light bends from the sharp edge and infers in the region of geometrical shadow. This phenomenon is known as diffraction of light.
(ii) A convex lens is placed in front of a monochromatic light source such that parallel light rays fall on a narrow slit.

Question 9.

- (a) In Young's double slit experiment using monochromatic light of wavelength 600 nm, 5th bright fringe is at a distance of 0.48 mm from the center of the pattern. If the screen is at a distance of 80 cm from the plane of the two slits, calculate : [3]
(i) Distance between the two slits.
(ii) Fringe width i.e., fringe separation.
- (b) (i) State Brewster's law.
(ii) Find Brewster's [2]

Answer:

(a) (i) $\lambda = 600 \text{ nm} = \frac{600}{1000000} \text{ mm}$
 $\lambda = 6 \times 10^{-4} \text{ mm}$
 $D = \text{Distance of slits from the screen} = 80 \text{ cm}$
 $D = 800 \text{ mm}$
 $\beta = \text{Fringe - width}$
 $5\beta = 0.48 \text{ mm}$
 $\therefore \beta = \frac{0.48}{5}$
(ii) $\beta = 0.096 \text{ mm}$
 $d = \text{distance between 2 slits}$
 $\beta = \frac{\lambda D}{d}$
 $\frac{0.48}{5} = \frac{6 \times 10^{-4} \times 8 \times 10^2}{d}$
 $\Rightarrow d = \frac{6 \times 8 \times 10^{-2} \times 5 \times 10^2}{48} = 5 \text{ mm}$

(b) (i) Brewster's law states that at polarisation, angle of incidence, reflected and refracted rays are at right angle to each other.

(ii) $\mu = \tan ip$ where $ip = \text{Brewster's angle}$
 $\therefore \tan ip = 1.5$
 $\therefore ip = \tan^{-1} 1.5$
 $ip = 56.3^\circ$

Question 10.

(a) Find critical angle for glass and water pair, given refractive index of glass is 1.62 and that of water is 1.33. [2]

(b) Starting with an expression for refraction at a single spherical surface, obtain Lens Maker's Formula. [3]

Answers :

(a) $\omega^{\mu_g} = \text{R. I of glass w.r.t water}$
 $= \frac{\mu_g}{\mu_w}$
 $\omega^{\mu_g} = \frac{1.62}{1.33}$

$$\therefore \sin c = \frac{1.33}{1.62} = 0.82$$

$$\therefore c = \text{Critical angle} = \sin^{-1} 0.82 = 55^\circ$$

(b)

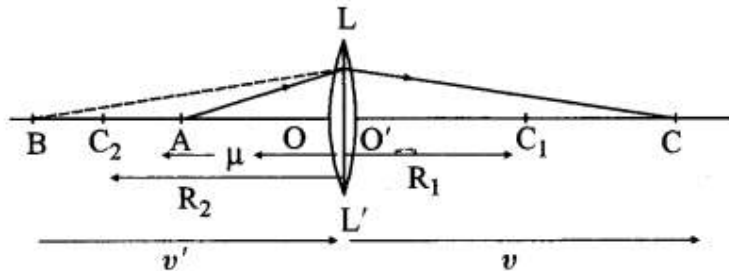

LOL' and LO'L' are the two curved surfaces forming a thin convex lens of radii R_1 and R_2 of refractive index μ . A is any object

After refraction through surface LOL', B is the virtual image. For surface LO'L', B behaves as object and after refraction e is the image.

\therefore For thin lens A is object and C is its image

For curved surface LOL', A = object; B = Image hence applying formula

$$\frac{\mu}{v} - \frac{1}{u} = \frac{\mu - 1}{R}$$

We have
$$\frac{\mu}{v'} - \frac{1}{u} = \frac{\mu - 1}{R_1} \quad \dots (1)$$

$$\therefore \frac{1}{v} - \frac{1}{u} = \frac{1}{R_2}$$

Hence
$$\frac{\mu}{v} - \frac{1}{v'} = \frac{\mu}{R_2} \quad \dots (2)$$

Multiplying eqn. (2) by μ , we have

$$\frac{1}{v} - \frac{\mu}{v'} = \frac{1 - \mu}{R_2} \quad \dots (3)$$

Adding eqn. (2) and (3)

$$\frac{1}{v} - \frac{1}{u} = \frac{\mu - 1}{R_1} + \frac{1 - \mu}{R_2}$$

$$\Rightarrow \frac{1}{f'} = (\mu - 1) \left(\frac{1}{R_1} - \frac{1}{R_2} \right)$$

where f' : is the second focal length of the lens.

Question 11.

(a) A compound microscope consists of two convex lenses of focal length 2 cm and 5 cm. When an object is kept at a distance of 2.1 cm from the objective, a virtual and magnified image is formed 25 cm from the eye piece. Calculate the magnifying power

of the microscope. [3]

(b) (i) What is meant by resolving power of a telescope ?

(ii) State any one method of increasing the resolving power of an astronomical telescope. [2]

Answer:

(a) For objective lens (L_0)

$$u_0 = -2.1 \text{ cm}$$

$$f_0 = 2 \text{ cm}$$

$$\frac{1}{f_0} = \frac{1}{v_0} - \frac{1}{u_0}$$

$$\Rightarrow \frac{1}{2} = \frac{1}{v_0} + \frac{1}{2.1}$$

$$\Rightarrow \frac{1}{v_0} = \frac{1}{2} - \frac{1}{2.1} = \frac{2.1 - 2}{4.2} = \frac{1}{42} \text{ cm}$$

$$v_0 = 42 \text{ cm}$$

$$\text{Magnifying power} = \frac{v_0}{u_0} \left(1 + \frac{D}{f_e} \right);$$

[\because Magnified image is formed 25 cm *i.e.*, least distance]

$$\text{Magnifying power} = \frac{42}{-2.1} \left(1 + \frac{25}{5} \right) = -\frac{42}{2.1} \times 6$$

$$\text{Magnifying power} = -120$$

negative sign shows the final image is inverted

(b) (i) Resolving power is the reciprocal of the smallest angular separation between two distant objects which can be observed distinctly using a telescope.

If $\theta \left[= \frac{1.22\lambda}{D} \right]$ be the angular separation, then resolving power = $\frac{1}{\theta} = \frac{D}{1.22\lambda}$;

[D = Aperture of objective lens]

(ii) By taking large aperture *i.e.*, increasing the size of the aperture the resolving power of lens is increased.

Section – C
(Answer any three questions)

Question 12.

(a) (i) Plot a labelled graph of V_s/f where V_s is stopping potential versus frequency f of the incident radiation.

(ii) State how will you use this graph to determine the value of Planck's constant. [3]

(b) (i) Find the de Broglie wavelength of electrons moving with a speed of $7 \times 10^6 \text{ ms}^{-1}$. [2]

(ii) Describe in brief what is observed when moving electrons are allowed to fall on a thin graphite film and the emergent beam falls on a fluorescent screen.

Answer:

(a) (i)

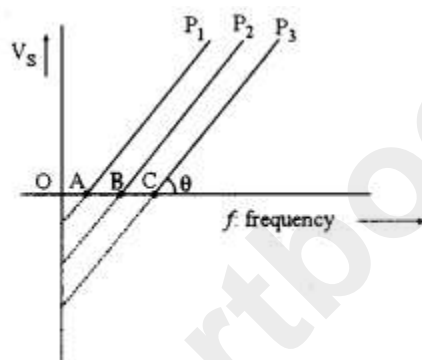

(ii) From the graph the slope, $\tan \theta = \frac{V_s}{f}$

$$\Rightarrow \tan \theta = \frac{h}{e} \left[\because V_s = \frac{h}{e} f \right]$$

$$\therefore h = \text{Planck's constant} = e \tan \theta$$

Thus, knowing the slope we can get the value of 'h' - Planck's constant.

(b) (i)

$\lambda =$ de-Broglie wavelength

$$\Rightarrow \lambda = \frac{h}{p} = \frac{h}{mv} = \frac{6.6 \times 10^{-34}}{9.1 \times 10^{-31} \times 7 \times 10^6} \text{ m}$$

$$\lambda = \frac{66 \times 10^{-9}}{91 \times 7}$$

$$\lambda = 0.1 \times 10^{-9} \text{ m}$$

$$\lambda = 0.1 \text{ nm}$$

(ii) Instead of bright spot, intensity of fluorescence will be low and scattered.

Question 13.

(a) Draw energy level diagram for hydrogen atom, showing first four energy levels corresponding to $n = 1, 2, 3$ and 4 . Show transitions responsible for : [3]

(i) Absorption spectrum of Lyman series.

(ii) Emission spectrum of Balmer series.

(b) (i) Find maximum frequency of X-rays produced by an X-ray tube operating at a tube potential of 66 kV. [2]

(ii) State any one difference between characteristic X-rays and continuous X-rays.

Answer:

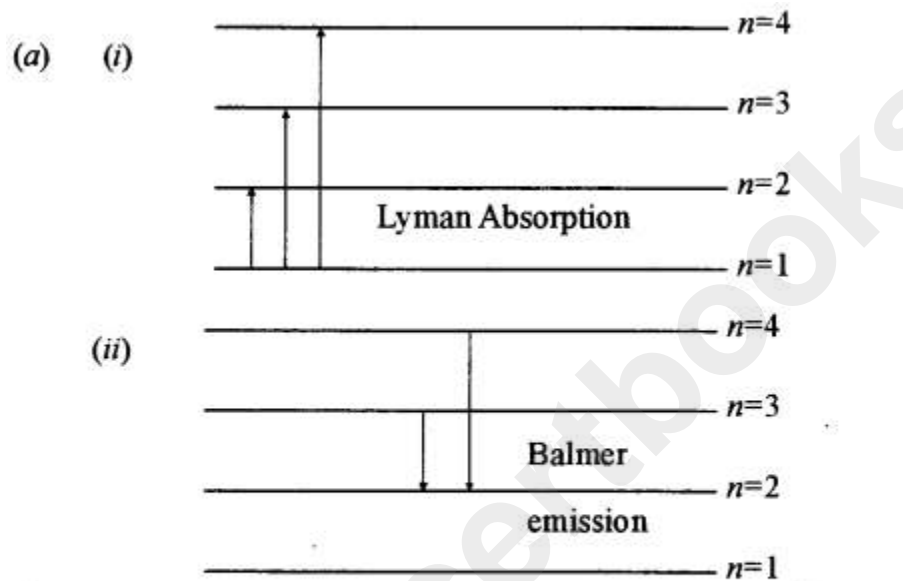

(b) (i) Potential difference $V = 66 \times 10^3 \text{ V}$

$$\text{Maximum frequency} = \frac{ev}{h}$$

$$= \frac{1.6 \times 10^{-19} \times 66 \times 10^3}{6.6 \times 10^{-34}}$$

$$= 1.6 \times 10^{-19} \times 10^4 \times 10^{34}$$

$$\text{Maximum frequency} = 1.6 \times 10^{19} \text{ Hz.}$$

(ii) Continuous X-ray consists of all possible wavelength of X-ray with lower wavelength limit whereas characteristic or line X-ray consists of definite wavelength superimposed on continuous X-ray.

Question 14.

(a) Obtain a relation between half life of a radioactive substance and decay constant (λ). [2]

(b) Calculate mass defect and binding energy per nucleon of ${}^{20}_{10}\text{Ne}$, given [3]

Mass of ${}^{20}_{10}\text{Ne} = 19.992397u$

Mass of ${}^1_1\text{H} = 1.007825u$

Mass of ${}^1_0\text{n} = 1.008665u$

Answer:

(a) At $t = T_{1/2}$ (half life), $N = \frac{N_0}{2}$

Putting this, into

$$N = N_0 e^{-\lambda t} \text{ [where } \lambda = \text{decay constant]}$$

We get

$$\frac{1}{2} = e^{-\lambda T_{1/2}}$$

\Rightarrow

$$\frac{1}{2} = \frac{1}{e^{\lambda T_{1/2}}} \Rightarrow e^{\lambda T_{1/2}} = 2$$

$$e^{\lambda T_{1/2}} = 2$$

Taking logarithm to both sides,

$$\lambda T_{1/2} = \log_e 2$$

\therefore

$$T_{1/2} = \frac{\log_e 2}{\lambda}$$

i.e.,

$$T_{1/2} = \frac{2.303 \times \log 10^2}{\lambda}$$

$$T_{1/2} = \frac{2.3 \times 0.301}{\lambda}$$

\therefore

$$T_{1/2} = \frac{0.692}{\lambda}$$

(b) Mass defect, $\Delta m = (\text{No. of proton} \times \text{mass of proton} + \text{No. of neutron} \times \text{mass of neutron}) - \text{Mass of Nucleus}$

$$\Delta m = (10 \times 1.007825 + 10 \times 1.008665) - 19.992397$$

$$= (10.07825 + 10.08665) - 19.992397$$

$$\Delta m = 0.172503$$

$$\text{Binding energy} = 0.172503 \times 931 \text{ MeV}$$

$$= 160.6 \text{ MeV}$$

\therefore

$$\text{Mass defect} = 0.172503 u$$

$$\text{Binding Energy} = 160.60 \text{ MeV}$$

Question 15.

(a) With reference to a semiconductor diode, what is meant by :

- (i) Forward bias
- (ii) Reverse bias
- (iii) Depletion region

(b) Draw a diagram to show how NAND gates can be combined to obtain an OR gate (Truth table is not required). [2]

Useful Constants and Relations :

1. Charge of a proton	(e)	$= 1.6 \times 10^{-19} \text{ C}$
2. Planck's constant	(h)	$= 6.6 \times 10^{-34} \text{ Js}$
3. Mass of an electron	(m)	$= 9.1 \times 10^{-31} \text{ kg}$
4. Permittivity of vacuum	(ϵ_0)	$= 8.85 \times 10^{-12} \text{ Fm}^{-1}$
5.	$\left(\frac{1}{4\pi\epsilon_0}\right)$	$= 9 \times 10^9 \text{ mF}^{-1}$
6. Permeability of vacuum	(μ_0)	$= 4\pi \times 10^{-7} \text{ Hm}^{-1}$
7.	$\left(\frac{\mu_0}{4\pi}\right)$	$= 1 \times 10^{-7} \text{ Hm}^{-1}$
8. Speed of light in vacuum	(c)	$= 3 \times 10^8 \text{ ms}^{-1}$
9. Unified atomic mass unit	(u)	$= 931 \text{ MeV}$
10. Electron volt	($1eV$)	$= 1.6 \times 10^{-19} \text{ J}$

Answers:

(a) (i) Forward bias: When a battery is connected to a p-n diode such that the current is in the direction of diode current, the arrangement is called forward bias.

(ii) If the current flows opposite to the direction of diode current, this is called reverse bias.

(iii) Depletion Zone : In p-n diode, the region in which electrons and holes neutralize each other is called depletion region or zone.

(b)

