

PHYSICS PAPER 1 (THEORY)

PART I (20 Marks)

Answer all questions.

Question 1

A. Choose the correct alternative (a), (b), (c) or (d) for each of the questions given below: [5]

(i) Relative permittivity of water is 81. If ϵ_w and ϵ_o are permittivities of water and vacuum respectively, then:

(a) $\epsilon_o = 9\epsilon_w$

(b) $\epsilon_o = 81\epsilon_w$

(c) $\epsilon_w = 9\epsilon_o$

(d) $\epsilon_w = 81\epsilon_o$

(ii) Five resistors are connected as shown in *Figure 1*.

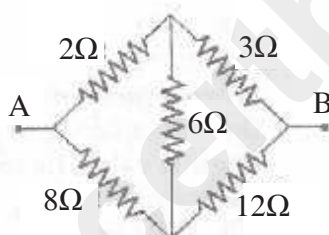

Figure 1

The effective resistance i.e. equivalent resistance between the points A and B is:

(a) 4Ω

(b) 5Ω

(c) 15Ω

(d) 20Ω

(iii) The **Biot Savart's** Law in **vector** form is:

(a) $\vec{\delta B} = \frac{\mu_o}{4\pi} \frac{d\vec{l}(\vec{I} \times \vec{r})}{r^3}$

(b) $\vec{\delta B} = \frac{\mu_o}{4\pi} \frac{I(d\vec{l} \times \vec{r})}{r^3}$

$$(c) \quad \vec{\delta B} = \frac{\mu_0}{4\pi} \frac{I(\vec{r} \times \vec{dl})}{r^3}$$

$$(d) \quad \vec{\delta B} = \frac{\mu_0}{4\pi} \frac{I(\vec{dl} \times \vec{r})}{r^2}$$

- (iv) In an astronomical telescope of refracting type:
- (a) Eyepiece has greater focal length.
 - (b) Objective has greater focal length.
 - (c) Objective and eyepiece have equal focal length.
 - (d) Eyepiece has greater aperture than the objective.
- (v) The particles which cannot be accelerated by a **cyclotron** or a **Van de Graff** generator are:
- (a) Alpha particles
 - (b) Beta particles
 - (c) Neutrons
 - (d) Protons

B. Answer **all** questions given below briefly and to the point:

[15]

- (i) A large hollow metallic sphere has a positive charge of $35.4 \mu\text{C}$ at its centre. Find how much **electric flux** emanates from the sphere.
- (ii) A current 'I' flows through a metallic wire of radius 'r' and the free electrons in it drift with a velocity v_d . Calculate the drift velocity of the free electrons through the wire of the **same material**, having double the radius, when **same** current flows through it.
- (iii) Name **any one** instrument which works on the principle of **tangent law** in magnetism.
- (iv) State the SI unit of **magnetic dipole moment**.
- (v) Alternating current flowing through a certain electrical device leads over the potential difference across it by 90° . State whether this device is a **resistor**, **capacitor** or an **inductor**.
- (vi) What is the shape of the wavefront diverging from a **point source of light**?
- (vii) The critical angle for a given transparent medium and air is i_c . A ray of light travelling in air is incident on this transparent medium at an angle of incidence equal to the polarising angle i_p . What is the relation between the two angles i_c and i_p ?

- (viii) Find the **focal length** and **nature** of a lens whose optical power is $-5D$.
- (ix) What is **Modulation**? Explain in brief.
- (x) What are the **dark lines** seen in the **solar spectrum** called?
- (xi) What is the relation between **wavelength** and **momentum** of moving particles?
- (xii) Name the series of lines in the hydrogen spectrum which lies in the **ultra-violet** region.
- (xiii) Fill in the blank in the given nuclear reaction:
- $$\text{_____} + {}_{13}^{27}\text{Al} \rightarrow {}_{12}^{25}\text{Mg} + {}_2^4\text{He}$$
- (xiv) Give an example where energy is converted into matter.
- (xv) To convert a pure semiconductor into **n**-type semiconductor, what type of impurity is added to it?

Comments of Examiners

- A. (i) Many candidates did not know that relative permittivity = dielectric constant and its value is >1 for all materials.
- (ii) A few candidates did not recognise that the given network was a balanced Wheatstone bridge. Evaluation of R_p from $1/R_1 + 1/R_2$ was wrong for many. Some applied Kirchhoff's law unnecessarily and incorrectly.
- (iii) Wrong choices were made by several candidates as many did not understand that the expression with cross product and current I is not a vector quantity.
- (iv) A number of candidates had no idea of the relative values of the focal lengths of the objective lens and the eyepiece, nor the reason for it. Hence, many wrong choices were made by candidates. In a few cases, aperture and focal length were mixed up.
- (v) Wrong options were chosen by some candidates due to lack of understanding of the principle of Cyclotron. Some gave the answer as 'alpha particles' as they are positively charged, not having read 'cannot be accelerated', in the question.

Suggestions for teachers

- Stress $\epsilon_r = k > 1$ for all materials. The value of $\epsilon_r = k$ is always $> \epsilon_0$. Point out that $\epsilon_r = k = \epsilon_w / \epsilon_0$. For any medium, $\epsilon = \epsilon_r \cdot \epsilon_0$.
- Teach the condition for a bridge to be balanced.
- It is the current element Idl that is a vector not the current I . The direction of magnetic field vector B is along the cross product $dl \times r$ not $rxdl$. Teach the properties of cross product of vectors very well.
- Point out that magnification $m = f_o / f_e$. So $f_o \gg f_e$ for high magnifying power. In the ray diagram, stress this aspect of telescope. Also mention larger aperture of objective enables more light to be gathered \rightarrow brighter I.

- B. (i) Many candidates gave flux $\phi = 0$ as they thought $E = 0$ inside a hollow sphere. They did not notice that there was a charge at the centre. Many candidates wrote the unit of electric flux incorrectly.
- (ii) Some candidates combined the full formulas, $I = v_d \cdot ena$ and area $a = \pi R^2$ resulting in unwanted lengthy calculations and mistakes.
- (iii) Answers like, cyclotron, galvanometer, moving coil galvanometer, vibration magnetometer and magnetometer were given which were all incorrect.
- (iv) Many candidates gave incorrect units: A/m^2 , $Tesla \cdot m^2$, etc.
- (v) Several candidates gave incorrect answers.
- (vi) Many candidates gave the shape of the wavefront as 'circle', which was incorrect.
- (vii) Many gave the expressions for i_c ($\sin i_c = 1/n$) and for i_p ($\tan i_p = n$); but did not connect these, whereas the question asked for the relation between i_c and i_p .
- (viii) The unit of 'f' was not given by many candidates. In some cases, the nature of the lens was given as convex.
- (ix) Most of the candidates did not have a clear idea as to what modulation is, hence they gave different types of modulations.
- (x) Many candidates answered this part incorrectly.
- (xi) A few candidates gave wrong formulae, such as, $p = h \cdot c / \lambda$
- (xii) Some candidates gave the wrong names: Balmer, Pfund, or Brackett series.
- (xiii) Many candidates gave wrong names: $(p+n)$, p or ${}_1H^1$.
- (xiv) Many candidates gave incorrect answers in this part.
- (xv) Some candidates gave the answer as, 'trivalent elements'; some wrote, 'acceptor elements'.

- The working principle and the limitations should be stressed. The what and why should be explained. Point out that Cyclotron can accelerate only charged particles (no neutrons); electrons have relativistic increase in mass violating the resonance condition required.
- Stress upon the correct use of Gauss' theorem, especially that the el flux $\phi = q/\epsilon_0$, where q is the *charge enclosed*.
- Explain clearly that Tangent law, $B_2 = B_1 \tan \theta$ has two crossed fields, B_1 and B_2 perpendicular to each other. So the devices based on tangent law must have two crossed magnetic fields. B_1 is usually the horizontal component of earth's field, B_{EH} ; B_2 is the artificial field produced by a bar magnet or a current carrying coil.
- Teach Phasor diagrams in detail, showing R , X_L and X_C along the $+X$, $+Y$ and $-Y$ directions respectively. Also, V_R , V_L and V_C ; along with their phase differences.
- Energy from a point source spread out in all direction in 3-dimensional space. The wave front is a sphere, not a circle. Illustrate with example of water wave (circles) in 2-D and sound propagation in 3-D space (spheres).
- Ask students to read the question carefully; note carefully what is asked and answer that specifically.
- Tell students that when power is in D , f is in m (not cm). Always include the correct unit in the final answer. Also, if power or focal length is $-ve$, it is a concave/diverging lens.

- New topics like modulation should be clearly explained with the help of diagrams and examples.
- Tell students that the names given to the first 3 series should be learned well with the help of energy level diagram.
- Teach the conservation law of Z and A in nuclear reactions. Also, let students learn the names of the first 10 elements with their Z and A values.
- Explain clearly what happens in pair production and mutual annihilation.
- Point out the 'n' in donor, pentavalent, and n-type. Also explain the difference between n-type and p-type semiconductors.

MARKING SCHEME

Question 1.

- (A) (i) (d) or $\epsilon_w = 81\epsilon_0$
- (ii) (a) or 4Ω
- (iii) (b) or $\vec{dB} = \frac{\mu_0}{4\pi} \frac{I(\vec{dl} \times \vec{r})}{r^3}$
- (iv) (b) or Objective has greater focal length.
- (v) (c) or Neutrons
- (b) Beta particles also may be accepted as a special case.
- (B) (i) $\Phi = \frac{q_{net}}{\epsilon_0} = \frac{35.4 \times 10^{-6}}{8.55 \times 10^{-12}} = 4 \times 10^6 \text{ Vm or C.m.F}^{-1} \quad \text{NC}^{-1} \text{ m}^2$
- (ii) $\frac{v_d}{4}$ or 1/4
- (iii) Deflection magnetometer OR
Tangent magnetometer OR
Tangent galvanometer. } any one

- (iv) $A.m^2$
- (v) Capacitor
- (vi) Spherical wavefront OR spherical OR sphere
- (vii) $\tan i_p = \frac{1}{\sin i_c}$ OR its equivalent
- (viii) Concave lens, or diverging lens $f = -20$ cm
- (ix) Combining an a.f. signal with a r.f. carrier wave or equivalent statement.
Superposition/overlapping or 3 diagrams
- (x) Fraunhofer lines
- (xi) $P = \frac{h}{\lambda}$ OR $\lambda = \frac{h}{p}$
- (xii) Lyman (series)
- (xiii) 2_1H OR 2_1D OR ${}^2_1H^2$ OR ${}^2_1D^2$ OR 2_1X OR 2_1Y
- (xiv) Pair production or equivalent $\gamma \rightarrow e^+ + e^-$ OR $h\nu \rightarrow e^+ + e^-$
Or labelled diagram
- (xv) Pentavalent element or donor impurity or name or element of 5th group

PART II (50 Marks)

Answer **six** questions in this part, choosing **two** questions
from **each** of the Sections **A**, **B** and **C**.

SECTION A

Answer any **two** questions.

Question 2

- (a) (i) Write an expression (**derivation not required**) for intensity of electric field in: [3]
 - (1) Axial position.
 - (2) Broad side position of an electric dipole, in terms of its length (2a) dipole moment (p) and distance (r).
- (ii) What is the ratio of these two intensities i.e. $E_1 : E_2$, for a **short** electric dipole?

- (b) Three capacitors $C_1 = 6\ \mu\text{F}$, $C_2 = 12\ \mu\text{F}$ and $C_3 = 20\ \mu\text{F}$ are connected to a 100 V battery, [3] as shown in **Figure 2** below:

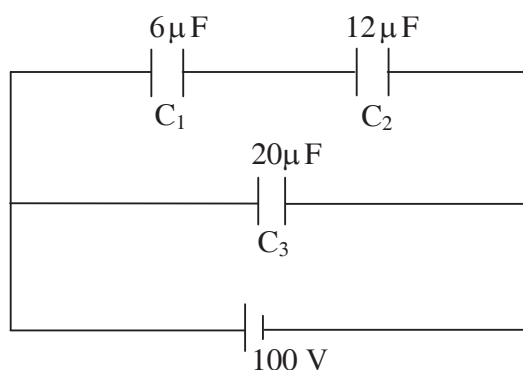

Figure 2

Calculate:

- (i) Charge on each plate of capacitor C_1
 - (ii) Electrostatic potential energy stored in capacitor C_3 .
- (c) 'n' cells, each of emf 'e' and internal resistance 'r' are joined in series to form a row. [3] 'm' such rows are connected in parallel to form a battery of $N = mn$ cells. This battery is connected to an external resistance 'R'.
- (i) What is the emf of this battery and how much is its internal resistance?
 - (ii) Show that current 'I' flowing through the external resistance 'R' is given by:

$$I = \frac{Ne}{mR + nr}$$

Comments of Examiners

- (a) (i) Many candidates gave the abridged formula for E in place of the complete formula required in the question.
(ii) For the ratio E_1/E_2 for a short electric dipole, the abridged formula was to be used. Many did not note that and used the un-abridged formula, resulting in clumsy results. Some got $E_1:E_2 = 1:2$ which was incorrect.
- (b) (i) Many candidates followed very lengthy methods. Some used the reciprocal relation for C_p ; Some carried 10^{-6} for μ in all substitutions. Mistakes were also made in simplifying the exponents.
(ii) Many candidates used wrong formulas. Some did not use $\mu = 10^{-6}$ correctly.
- (c) The *emf* of the battery was wrongly given as ne/m or mne . Total internal resistance and total resistance were also given incorrectly. Some candidates gave total internal resistance $r' = r/n$ instead of $n.r/m$.

Suggestions for teachers

- Instruct students to read the question carefully, noting carefully what exactly is asked and giving just that.
- Explain clearly how the pd and charge combine in series and parallel combination of capacitors. The differences in charge and pd should be well understood.
- Stress upon the importance of the three formulas for U . Solve typical problems.
- The total *emf* for each row is $n.e$ and for m such rows (battery), the *emf* is the same as for each row, ne . Explain that the internal resistance adds up in each row (nr) and divides for m rows (nr/m).

MARKING SCHEME

Question 2.

$$(a) \quad E_1 = \frac{1}{4\pi\epsilon_0} \frac{2pr}{(r^2 - a^2)^2}$$

$$E_2 = \frac{1}{4\pi\epsilon_0} \frac{p}{(r^2 + a^2)^{3/2}}$$

$$E_1 : E_2 = 2 : 1$$

$$(b) \quad (i) \quad C_{12} = \frac{C_1 C_2}{C_1 + C_2} = \frac{6 \times 12}{6 + 12} = 4 \mu\text{F}$$

$$Q_1 = Q_{12} = C_{12} V = 4 \times 10^{-6} \times 100 = 4 \times 10^{-4} \text{C} \\ = 400 \mu\text{C}$$

OR

$$Q = \frac{C_1 C_2}{C_1 + C_2} V \\ = \frac{6 \times 12}{6 + 12} \times 100 \\ = 400 \mu\text{C}$$

Correct substitution with or

Without (correct) formula

Correct result with proper unit

$$(ii) \quad U = \left(\frac{1}{2} CV^2 \right) = \frac{1}{2} \times 20 \times 10^{-6} \times (100)^2 \\ = 1 \times 10^{-1} \text{ J} \quad \text{OR} \\ = 0.1 \text{ J}$$

$$(c) \quad (i) \quad \text{emf} = ne$$

$$\text{internal resistance, } r' = \frac{nr}{m}$$

$$(ii) \quad I = \frac{E}{R + r} = \frac{ne}{R + \frac{nr}{m}} = \frac{mne}{(mR + nr)} = \frac{Ne}{(mR + nr)}$$

Question 3

- (a) In the circuit shown in **Figure 3**, $E_1 = 17\text{ V}$, $E_2 = 21\text{ V}$, $R_1 = 2\Omega$, $R_2 = 3\Omega$ and $R_3 = 5\Omega$. [4]
Using **Kirchoff's laws**, find the currents flowing through the resistors R_1 , R_2 and R_3 .
(Internal resistance of each of the batteries is negligible.)

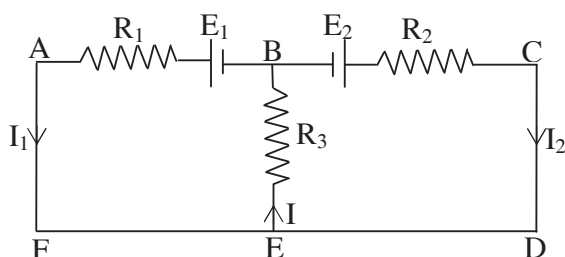

Figure 3

- (b) You are provided with one low resistance R_L and one high resistance R_H and two galvanometers. One galvanometer is to be converted to an ammeter and the other to a voltmeter. Show how you will do this with the help of simple, labelled diagrams. [2]
- (c) (i) Plot a labelled graph to show variation of thermo-emf 'e' versus temperature difference ' θ ' between the two junctions of a thermocouple. [3]
Mark 'N' as **neutral temperature** and 'I' as **temperature of inversion**.
- (ii) What is **Peltier effect**?

Comments of Examiners

- (a) The sign convention was applied wrongly by many candidates. In some cases, the solution of the two simultaneous equations was attempted using very lengthy and incorrect methods. Several candidates changed the direction of arrows given in the question paper. Some did not know Kirchoff's laws or its applications.
- (b) Disregarding the given labels, R_L and R_H many candidates used 'S' and 'R' for shunt and series resistors. Others gave detailed derivations of the expressions for S and R which were not asked for.
- (c) The shape of the graph was wrong in several cases. The points N and I were marked wrongly by a number of candidates. Many candidates did not know Peltier effect at all.

Suggestions for teachers

- Use $\Sigma \varepsilon + \Sigma IR = 0$, (not $\Sigma \varepsilon = \Sigma IR$). Also, take the loop direction against current so that IR is +ve. Explain well what is +ve for *emf* and for p.d = $V = IR$.
- Teach students how to solve simultaneous equations in easy steps.
- Tell students not to change symbols and the directions of the arrows given in the diagrams in the question paper.
- Ask students to read the questions very carefully and to follow the directions strictly.
- This simple graph should be taught well, pointing out the correct shape and the location of the points N and I.

MARKING SCHEME

Question 3.

(a) $I = I_1 + I_2$

$-I \times 5 - 2 I_1 + 17 = 0$

OR

$5I + 2 I_1 = 17$

Equation 1:

$7 I_1 + 5 I_2 = 17$

OR

$-I \times 1 - 6 I_2 - 1 I_2 + 10 = 0$

OR

$5I + 3I_2 = 21$

OR

Equation 2:

$5I_1 + 8 I_2 = 21$

Solving the two simultaneous equations; show some working

$I_1 = 1 \text{ A}$

$I_2 = 2 \text{ A}$

$\therefore I = 3 \text{ A}$

ECF applicable, if one of the equations is wrong.

ECF applicable, if both the equations are wrong.

(b) (i) To convert galvanometer to ammeter:

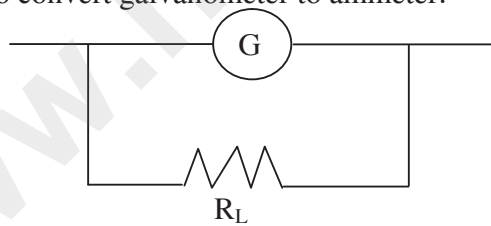

(ii) To convert galvanometer to voltmeter:



(c) (i)

Correct labelling: e on Y axis; θ on x axis.
: N for neutral temp.
: I or temperature of immersion

Correct shape of the graph

(ii) When a current is passed through a thermo-couple, one of its junctions gets heated whereas the other gets cooled or equivalent.

Question 4

- (a) **Figure 4** below shows two infinitely long and thin current carrying conductors X and Y kept in vacuum, parallel to each other, at a distance 'a'. [2]

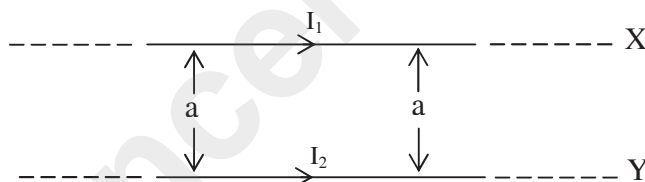

Figure 4

- (i) How much force per unit length acts on the conductor Y due to the current flowing through X? Write your answer in terms of $\left(\frac{\mu_0}{4\pi}\right)$, I_1 , I_2 , and a.

(Derivation of formula is not required.)

- (ii) Define **ampere**, in terms of force between two current carrying conductors.

- (b) A metallic rod CD rests on a thick metallic wire PQRS with arms PQ and RS parallel to each other, at a distance $l = 40 \text{ cm}$, as shown in **Figure 5**. A uniform magnetic field $B = 0.1 \text{ T}$ acts perpendicular to the plane of this paper, pointing inwards (i.e. away from the reader). The rod is now made to slide towards right, with a constant velocity of $v = 5.0 \text{ ms}^{-1}$. [3]

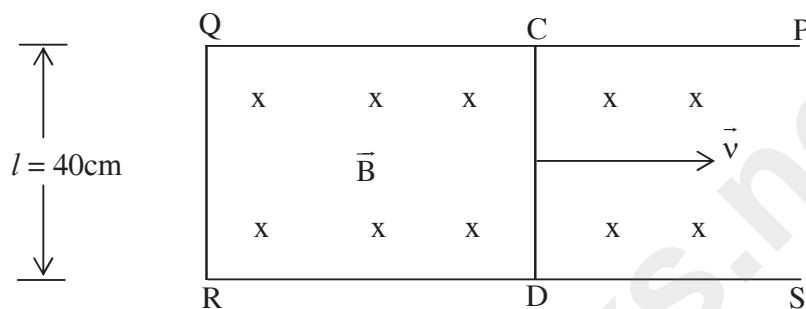

Figure 5

- (i) How much emf is induced between the two ends of the rod CD ?
- (ii) What is the direction in which the induced current flows?
- (c) (i) **Figure 6** below shows a series RCL circuit connected to an ac source which generates an alternating emf of frequency 50 Hz. The readings of the voltmeters V_1 and V_2 are 80 V and 60 V respectively. [4]

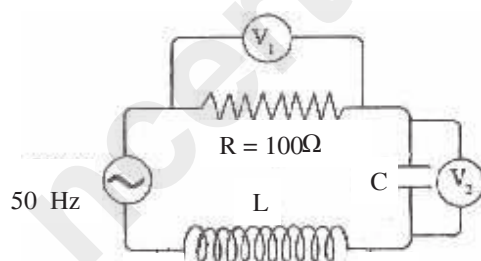

Figure 6

Find:

- (1) the current in the circuit.
 - (2) the capacitance C of the capacitor.
- (ii) At resonance, what is the relation between impedance of a series LCR circuit and its resistance R ?

Comments of Examiners

- (a) (i) The expression for F/l was wrong for many candidates. Several candidates derived the formula unnecessarily.
(ii) A number of candidates were not able to define 'Ampere' correctly.
- (b) (i) The $\text{emf} = B.L.v$ was simple substitution but many candidates did it incorrectly as $L = 40 \text{ cm}$ was not changed to 0.40 m .
(ii) Direction of induced current was given wrongly by many candidates.
- (c) (i) A number of candidates did not recognize $I = V/R$ and made some wrong calculations. Mistakes were also made in simplifying and solving for C from $X_c = 1/\omega C = 1/2\pi fC$.

Suggestions for teachers

- Ask students to read the questions very carefully. Tell them to do just what is asked, strictly following the directions.
- Ampere, the base unit of electricity is defined from the expression, $F/l = (\mu_0/2\pi) I_1 I_2/a$. So, stress (i) $I_1 = I_2 = I = 1 \text{ A}$, if $a = 1 \text{ m}$, $F/l = 2 \times 10^{-7} \text{ N/m}$, when the conductor is very long and is placed in vacuum.
- Emphasize the unit of each physical quantity. In numerical problems, in most cases, all data should be in SI units.
- Teach carefully, the use of Lenz's law to obtain the direction of the induced current; 'so as to oppose the action which causes it.'
- Help students understand that in an LCR circuit, current, I is the same in all components. So, the simplest formula for I is, $I = V/R$.

MARKING SCHEME

Question 4.

- (a) (i) $F = \left(\frac{\mu_0}{4\pi} \right) \frac{2I_1 I_2}{a}$ OR $\frac{\mu_0 I_1 I_2}{2\pi a}$
- (ii) Current flowing through each of the two (infinitely) long (thin) conductors is said to be 1 A if they attract or repel each other with a force of $2 \times 10^{-7} \text{ Nm}^{-1}$, when they are kept parallel to each other at a distance of 1 m in vacuum.
(must mention 2×10^{-7} and either Nm^{-1} or 1 m accepted)
- (b) (i) $e = Blv$
 $= 0.1 \times 0.4 \times 5.0$
 $e = 0.2 \text{ V}$
Correct substitution or correct formula
Correct result with unit
- (ii) From D to C or along DCQR

- (c) (i)
1. $I = \frac{V_R}{R} = \left(\frac{80}{100}\right) = 0.8 \text{ A}$
 2. $X_c = \frac{1}{2\pi f C} = \frac{V_C}{I} = 75 \Omega$ or implied
- $$\frac{1}{2\pi \times 50 \times C} = \frac{60}{0.8} \quad \text{or } \omega = 2\pi f = 2 \times 3.142 \times 50 = 314.2 \text{ rad/s}$$
- $$\therefore C = 42.5 \mu\text{F} \left. \vphantom{\begin{matrix} \therefore C = 42.5 \mu\text{F} \\ 43 \mu\text{F} \end{matrix}} \right\} \\ 43 \mu\text{F}$$
- Accept $C = 42$ to $43 \mu\text{F}$
- (ii) $Z = R$

SECTION B

Answer any two questions

Question 5

- (a) (i) In an electromagnetic wave, how are electric vector (\vec{E}), magnetic vector (\vec{B}) and velocity of propagation of the wave (\vec{c}) oriented? [2]
- (ii) How long would **gamma radiation** take to travel from sun to earth, a distance of $1.5 \times 10^{11} \text{ m}$?
- (b) With the help of a labelled diagram, show that fringe separation β in **Young's double slit** experiment is given by: [4]

$$\beta = \frac{\lambda D}{d}$$

where the terms have their usual meaning.

- (c) (i) What is the difference between **polarised** light and **unpolarised** light based on the direction of electric vector (\vec{E})? [2]
- (ii) What will be the effect on the **width** of the **central bright fringe** in the diffraction pattern of a single slit if:
- (1) Monochromatic light of smaller wavelength is used.
 - (2) Slit is made narrower.

Comments of Examiners

- (a) (i) Instead of saying that E, B, and c are mutually perpendicular, many candidates mentioned about planes.
 (ii) Some candidates did not know that $v = c = 3.0 \times 10^8$ m/s. Several candidates made mistakes in simplifying the exponential. At times, the unit was wrong.
- (b) Steps were left out by many candidates in this part.
- (c) (i) Many candidates did not know the relation between the electric field E and the state of polarization and hence could not answer correctly.
 (ii) Several candidates were not able to answer this part correctly.

Suggestions for teachers

- Explain to students that the speed of all e.m. radiation is $c = 3.0 \times 10^8$ m/s in vacuum/air. Teach the the rules for simplifying exponents.
- Emphasise the importance of reading questions very carefully.

MARKING SCHEME

Question 5.

- (a) (i) They are mutually perpendicular to each other OR correct diagram.

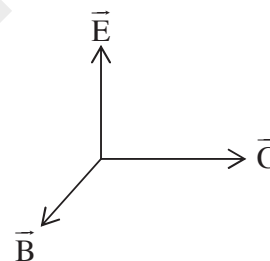

(ii)
$$t = \frac{S}{C}$$

$$= \frac{1.5 \times 10^{11}}{3 \times 10^8}$$

$$= 0.5 \times 10^3 \text{ OR } 500 \text{ s}$$

- (b)

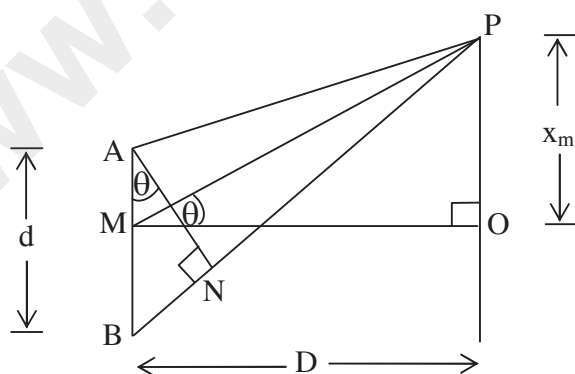

In ΔPMO , $\tan \theta = \frac{PO}{MO} = \frac{x_m}{D}$

Path difference = $BP - AP = BN = AB \sin \theta = d \sin \theta$

For a bright fringe to be formed at P, $d \sin \theta = m\lambda$

$$\text{In } \triangle BAN, \sin \theta = \frac{BN}{AB} = \frac{m\lambda}{d}$$

$$\tan \theta = \sin \theta \quad \therefore \theta \text{ is small}$$

$$\therefore \frac{x_m}{D} = \frac{m\lambda}{d}$$

$$\therefore X_m = \frac{m\lambda D}{d}$$

$$\text{Fringe width } \beta = x_1 = \frac{1 \cdot \lambda D}{d} \quad \text{OR}$$

$$\begin{aligned} \text{Fringe width } \beta &= x_m - x_{m-1} = \frac{m\lambda D}{d} - (m-1) \frac{\lambda D}{d} \\ &= \frac{\lambda D}{d} \end{aligned}$$

Second method:

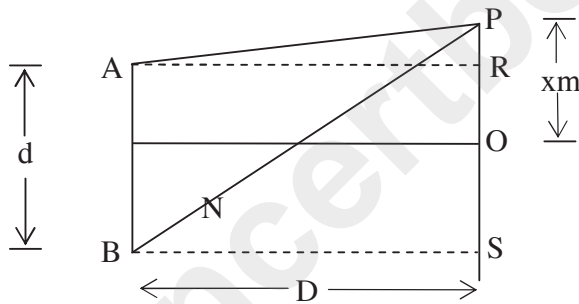

$$\left. \begin{aligned} BP^2 &= BS^2 + SP^2 \\ &= D^2 + \left(x_m + \frac{d}{2}\right)^2 \\ AP^2 &= AR^2 + RP^2 \\ &= D^2 + \left(x_m + \frac{d}{2}\right)^2 \end{aligned} \right\}$$

$$BP^2 - AP^2 = \left(x_m + \frac{d}{2}\right)^2 - \left(x_m + \frac{d}{2}\right)^2$$

$$(BP - AP) (BP + AP) = 2 x_m \cdot d$$

$$(BP - AP) \cancel{D} = \cancel{D} x_m \cdot d$$

$$m\lambda \cdot D = x_m d$$

$$\therefore x_m = \frac{m\lambda D}{d}$$

$$\text{Fringe width } \beta = x_1 \frac{1\lambda D}{d} = \frac{\lambda D}{d}$$

- (c) (i) In unpolarised light, electric vector points in all directions or infinite number of directions in a plane, perpendicular to the direction of propagation whereas in polarised light, it points in only one direction which is perpendicular to the direction of propagation of light OR correct diagram.

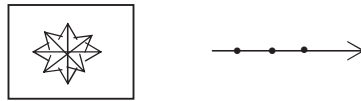

- (ii) (1) decreases
(2) increases

Question 6

- (a) At what angle, a ray of light should be incident on the first face AB of a regular glass prism ABC so that the emergent ray grazes the adjacent face AC ? [3]

See **Figure 7** below. (Refractive Index of glass = 1.6)

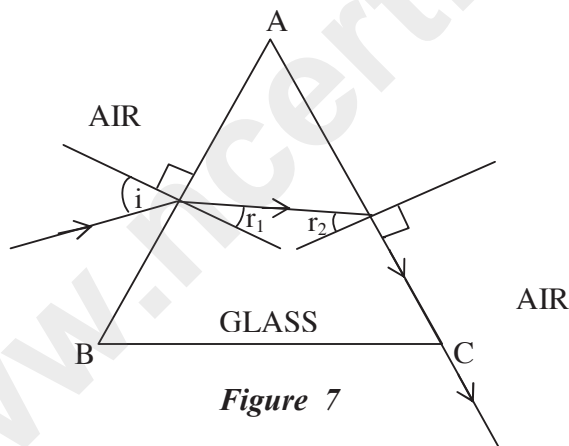

Figure 7

- (b) A convex lens 'L' and a plane mirror 'M' are arranged as shown in **Figure 8** below. [2]
Position of object pin 'O' is adjusted in such a way that the inverted image 'I' formed by the lens mirror combination, coincides with the object pin 'O'. Explain how and when this happens.

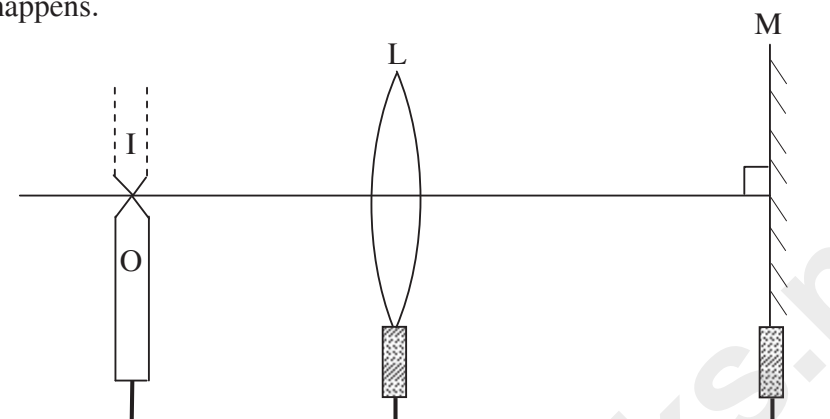

Figure 8

- (c) Starting with an expression for refraction at a **single spherical surface**, obtain an [3]
expression for **lens maker's formula**.

Comments of Examiners

- (a) Many candidates got confused and used very complicated formulas. Some candidates used the formula for min. deviation.
- (b) A number of candidates did not know that the image formation was due to rays returning to O after refraction through the lens and reflection from the mirror. Hence they did not mention the position of the object pin as the focus of the lens. Many wrong answers were given.
- (c) Several candidates derived the expression for refraction at a single spherical surface. This was not asked, this was to be assumed. It was clearly given in the question. Candidates also made mistakes in the sign convention used.

Suggestions for teachers

- Teach well the concept of critical angle of incidence, with $r = 90^\circ$; grazing angle of incidence, $\sin c = 1/n$; $(\sin i / \sin r) = n$; $r_1 + r_2 = A = 60^\circ$ etc. Encourage step by step calculation.
- Different cases of the incident rays retracing their path after reflection from (i) a plane mirror and (ii) a convex /concave mirror must be taught with the help of ray diagrams and explanation of the 'why' in each case should be done. Also, do image formation with a combination of lens and mirror.
- Ask students to read the questions very carefully and do just what is asked following the directions given.
- Discourage the learning of derivations by heart. Students should be made to understand the logic behind each step.

MARKING SCHEME

Question 6.

$$(a) \quad r_2 = c = \sin^{-1}\left(\frac{1}{\mu}\right) = \sin^{-1}\left(\frac{1}{1.6}\right)$$
$$= 38.7^\circ$$

$$r_1 = A - C$$

$$= 60^\circ - 38.7 = 21.3^\circ$$

$$\frac{\sin i}{\sin r_1} = \mu \text{ OR } \sin i = \mu \sin r_1$$

$$\sin i = 1.6 \times \sin(21.3^\circ)$$

$$\therefore i = 35.5^\circ$$

- (b) This happens when the object pin is kept at the focus of the lens.

Rays of light emerging from the lens become **parallel** to each other and to the principal axis of the lens. These rays fall on the plane mirror **normally** and hence get reflected back. The rays now retrace their path and meet at the focus of the lens, i.e. the image coincides with the object pin. OR ray diagram with f or F marked.

- (c) For the refraction at first (convex) spherical surface;

$$\frac{\mu}{v} - \frac{1}{u} = \frac{(\mu - 1)}{R_1}$$

For refraction at second spherical surface;

$$\frac{1}{v} - \frac{\mu}{v'} = \frac{(\mu - 1)}{R_2}$$

Adding:

$$\frac{1}{v} - \frac{1}{u} = (\mu - 1) \left(\frac{1}{R_1} - \frac{1}{R_2} \right)$$

$$\frac{1}{f} = (\mu - 1) \left(\frac{1}{R_1} - \frac{1}{R_2} \right)$$

Correct diagram

Question 7

- (a) Show that the **axial chromatic aberration** ($f_r - f_v$) for a convex lens is equal to the product of its mean focal length (f) and dispersive power (ω) of its material i.e. Prove: [3]

$$f_r - f_v = \omega f.$$

- (b) Draw a labelled diagram of an image formed by a **compound microscope**, with the image at **least distance of distinct vision**. Write any one expression for its magnifying power. [3]

- (c) What is meant by **long-sightedness**? How can this defect be corrected? [2]

Comments of Examiners

- (a) The starting expression for $1/f = (n-1)(1/R_1 - 1/R_2)$ was given incorrectly by several candidates. The definition of ω was wrong. Many candidates gave no explanation for the steps.
- (b) Many candidates made mistakes in the diagram of compound microscope: F_1 , F_2 , *arrows* on rays were not shown; formation of image I_1 was not correctly shown. Formation of I_2 at D was not correctly shown. In some Expression for m was not correct.
- (c) Several candidates did not know the meaning of long-sightedness. For correction, some wrote 'concave lens', in place of 'convex lens'.

Suggestions for teachers

- Explain the starting equation and the 'why' of each step well. Ask students not to learn derivations by heart.
- In teaching/learning, make sure that 'compound microscope' is not left out or neglected. Draw neat labelled diagrams on the black board; explain the formation of images as well as the magnifying power $m = m_o \times m_e$. At least one arrow is a must for each ray.
- Ask students to study carefully the physics behind the defects of the eye and its correction, using neat ray diagrams. Differentiate between long sightedness and short sightedness.

MARKING SCHEME

Question 7.

(a)

$$\frac{1}{f_r} = (\mu_r - 1) \left(\frac{1}{R_1} + \frac{1}{R_2} \right)$$
$$\frac{1}{f_v} = (\mu_v - 1) \left(\frac{1}{R_1} + \frac{1}{R_2} \right)$$
$$\frac{1}{f_v} - \frac{1}{f_r} = (\mu_v - \mu) \left(\frac{1}{R_1} + \frac{1}{R_2} \right)$$

$$\frac{f_r - f_v}{f_r f_v} = (\mu - 1) \left(\frac{\mu_v - \mu_r}{\mu - 1} \right) \left(\frac{1}{R_1} - \frac{1}{R_2} \right)$$

$$\frac{1}{f} = (\mu - 1) \left(\frac{R}{1} - \frac{R}{2} \right) \quad \sin \omega = \frac{\mu_v - \mu_r}{\mu - 1} \quad \text{or implied}$$

$$\frac{f_r - f_v}{f^2} = \omega \cdot \frac{1}{f}$$

$$\therefore [f_r - f_v = \omega f]$$

- (b) Two incident rays from an object + objective, with at least one arrow.
Two emergent rays with at least one arrow + eyepiece, with inverted image at D.

$$M = M_e M_o \quad \text{OR}$$

$$= \left(1 + \frac{D}{f_e} \right) \frac{v_o}{u_o} \dots \text{OR}$$

$$= \left(1 + \frac{D}{f_e} \right) \left(\frac{v_o}{f_o} - 1 \right)$$

- (c) (It is that defect of vision)

A person can't see objects at and beyond D (25 cm) upto his near point.

It can be corrected by using a convex lens (of appropriate focal length).

SECTION C

Answer any **two** questions.

Question 8

- (a) (i) What is meant by '**Quantization of charge**'? [3]
(ii) In Thomson's experiment, prove that the ratio of **charge to the mass** (e/m) of an electron is given by:

$$\frac{e}{m} = \frac{1}{2V} \cdot \frac{E^2}{B^2}$$

where the terms have their usual meaning.

- (b) In a photo-electric cell, a retarding potential of 0.5V is required to block the movement of electrons from the cathode when monochromatic light of wavelength 400 nm is incident on its surface. Find the **work function** of the material of the cathode. [3]

(c) Name a **phenomenon** or an **experiment** which proves:

[2]

(i) Particle nature of electro magnetic radiations.

(ii) Wave nature of particles.

(Description of the phenomenon / experiment is **not** required.)

Comments of Examiners

(a) (i) In place of $Q = ne$, some candidates wrote, Q is a simple multiple of ... which is not correct.

(ii) Many candidates were confused between v (velocity) and V (pd).

(b) Some candidates calculated λ_0 unnecessarily. Many candidates used very lengthy methods in the solution; mistakes were also made by candidates in calculating/ converting energy in joules, not taking common factors, simplifying exponents in the values of h, c and λ .

(c) (i) For an experiment or phenomenon which proves the particle nature of *em* radiation, some candidates gave Plank's quantum theory or de Broglie equation which was not correct.

(ii) For wave nature of particles, many candidates wrote - reflection, refraction, etc which was incorrect.

Suggestions for teachers

- Teach the mathematical statement, $Q = n.e$ where n is an integer and e is the charge on an electron.
- Stress upon the convenience of using eV for energy unit in modern physics problems. The work out is much simpler and easier. Work function is usually given in eV. Also, point out that when retarding/stopping potential V is given, work function in eV is simply = V (numerically).
- Explain the importance/relevance of photoelectric effect and Compton effect. These can be explained only assuming quantum nature of radiation (not its wave nature).

MARKING SCHEME

Question 8.

(a) (i) The charge on any body is always an /integral multiple of elementary charge ($\pm e$)

OR

$Q = \pm ne$ where n is an integer.

(ii) $\frac{1}{2}mv^2 = eV$ OR

$$\frac{e}{m} = \frac{v^2}{2V}$$

$$Bev = eE \quad \text{OR} \quad v = \frac{E}{B}$$

(b)
$$eVs = \frac{hc}{\lambda} - \omega$$

OR

$$\omega = \frac{hc}{\lambda} - eV_s$$

For hc/λ or eVs calculation

$$\begin{aligned}\omega &= \frac{6.63 \times 10^{-34} \times 3 \times 10^8}{400 \times 10^{-9}} - 0.8 \times 10^{-19} \\ &= 4.1725 \times 10^{-19} \text{ J}\end{aligned}$$

OR

$$\omega = 2.61 \text{ eV} \quad \text{Or may do in eV complete solution.}$$

- (c) (i) Photo electric effect OR
Compton effect OR
Raman effect.
- (ii) Electron diffraction OR
Davisson & Germer's experiment OR
GP Thomsons experiment.

Question 9

- (a) (i) State the postulate of **Bohr's theory** regarding: [3]
- (1) Angular momentum of an electron.
 - (2) Emission of a photon.
- (ii) Total energy of an electron orbiting around the nucleus of an atom is always negative. What is the significance of this?
- (b) (i) Draw a labelled graph showing variation of relative intensity of X-rays versus their wavelength λ . Mark λ_{\min} on the graph. [3]
- (ii) State how the value of λ_{\min} can be varied.
- (c) **Half life** of a certain radioactive substance is 6 hours. If you had 3.2 kg of this substance in the beginning, how much of it will disintegrate in one day? [2]

Comments of Examiners

- (a) (i) Some candidates unnecessarily explained the postulates, while only the statement was asked. Emission of electrons was not explained properly by many candidates. Some candidates gave the condition for emission of photoelectrons.
(ii) The significance of –ve energy was not known to many candidates. The word ‘significance’ was also not understood by some.
- (b) (i) The shape of the graph and position of λ_{\min} were not correct in many cases. At times, the right arm of the graph was shown as coming down steeply. Labelling of axes not correct for some candidates.
(ii) Many candidates mentioned just potential or pd without specifying Anode potential or Tube potential.
- (c) Some candidates made very lengthy calculations. Mistakes were also made in simplification.

Suggestions for teachers

- Teach the statement of postulates in words and in equation form. $L = n.h/2\pi$ and ΔE or $(E_f - E_i) = hf = hc/\lambda$.
- Tell students that the kinetic energy is always +ve; but potential energy of electron-proton system (H atom) is always –ve because of the attractive force. Total energy $E = U + K$ is always –ve for a bound system like H atom. This should be explained clearly with numerical values also.
- Explain the difference between anode potential and filament potential.
- Teach the concept of half-life with numerical examples. Explain the difference between the amount which decays and the amount left after decay.

MARKING SCHEME

Question 9.

- (a) (i) 1) Angular momentum of an electron is quantized OR
(Electron revolves around the nucleus in that orbit where) its angular momentum is an integral multiple of $\left(\frac{h}{2\pi}\right)$ or (t) OR
 $l = nt$ or $\frac{nh}{2\pi}$
- 2) An atom emits energy/photon when its electron jumps from higher excited state to a lower excited state or ground state. Or equivalent formula.
- (ii) It means electron is bound to be nucleus OR
electron can't leave the atom unless it is provided with sufficient / enough energy. OR
atom is in bound/stable state. OR
energy is required to remove an electron from an atom.

(b)

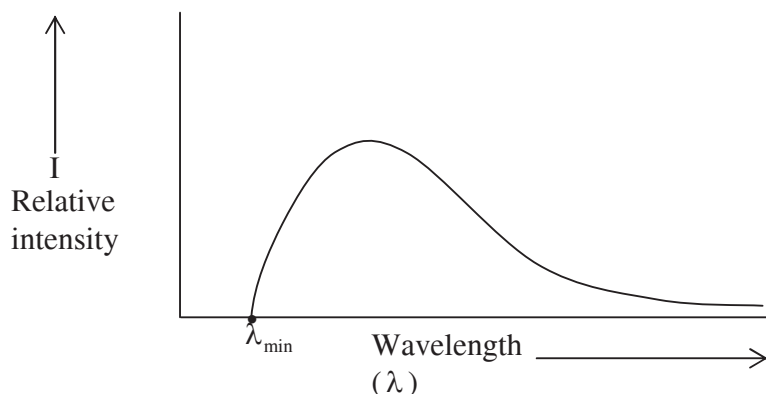

- (i) Axes correctly labelled
- (ii) Correct shape of the graph (with or without peaks/spikes)
With λ_{\min} marked
 λ_{\min} depends on tube potential i.e. potential difference between
The cathode and the anode.

(c) (1 day = 24 hours = 4T)

3.2 kg T 1.6kg 2T 0.8kg 3T 0.4kg

0.4 kg \rightarrow 0.2kg OR using $N = N_0 \cdot (1/2)^n$ where $n = t/T$

Amount disintegrated = 3.0 kg

Question 10

- (a) (i) What is the significance of **binding energy per nucleon** of a nucleus? [3]
- (ii) In a certain star, three alpha particles undergo **fusion** in a single reaction to form $^{12}_6\text{C}$ nucleus. Calculate the energy released in this reaction in MeV.
Given : $m(^4_2\text{He}) = 4.002604 \text{ u}$ and $m(^{12}_6\text{C}) = 12.000000 \text{ u}$.
- (b) Show by drawing labelled diagrams, the nature of output voltages in case of: [3]
- (i) A half wave rectifier.
- (ii) A full wave rectifier.
- (iii) An Amplifier.
- (In each case, input is an ac voltage)

Circuit diagrams of these devices are not required.

(c) Identify the logic gate whose truth table is given below and draw its symbol:

[2]

A	B	Y
0	0	1
0	1	1
1	0	1
1	1	0

Comments of Examiners

- (a) (i) Many candidates gave the definition of BE/nucleon, which was not asked. The 'significance' of BE per nucleon was asked.
 (ii) Calculation of mass defect, Δm was wrong in several cases, as candidates did not use 3 in $3m(\text{He})$ or did not subtract correctly. Some candidates wrongly used $E = m.c^2$ with m in u. Some did $E = E_1 - E_2$ which was very lengthy.
- (b) Many candidates gave full circuit diagrams which were not asked. Input signal was not asked but many candidates gave that also. Some candidates did not label the axes.
- (c) A number of candidates identified it as AND + NOT gate. Some wrote 'AND' gate. Many copied the Truth Table which was not required. The symbol of NAND gate was wrong in a few cases.

Suggestions for teachers

- Explain with example that high values of BE/A signifies high stability.
- Teach students to first calculate Δm in u only very carefully. To convert the mass defect in u to energy in MeV, use the conversion factor, $1 = 931 \text{ MeV/u}$. Also, explain that $E = m.c^2$ is valid only with mass m in kg. Here, $c = 3.0 \times 10^8 \text{ m/s}$.
- Stress upon labelling the axes for graphs. Explain the function and working of each device.
- Ask students to do just what is asked following the directions strictly and not to copy diagrams and tables from the question paper to the answer sheet.

MARKING SCHEME

Question 10.

- (a) (i) It gives us an idea of the relative stability of the nucleus.

(ii)
$$\Delta m = \left[3m\left({}^4_2\text{He}\right) \right] - \left[m\left({}^{12}_6\text{C}\right) \right]$$

OR

$$\left. \begin{aligned} (3 \times 4002604 - 12.0000) \text{u} \\ = 0.007812 \text{ u} \end{aligned} \right\}$$

$$\begin{aligned} \text{Energy released, } E &= 0.007812 \times 931 \\ &= 7.27 \text{ (MeV)} \end{aligned}$$

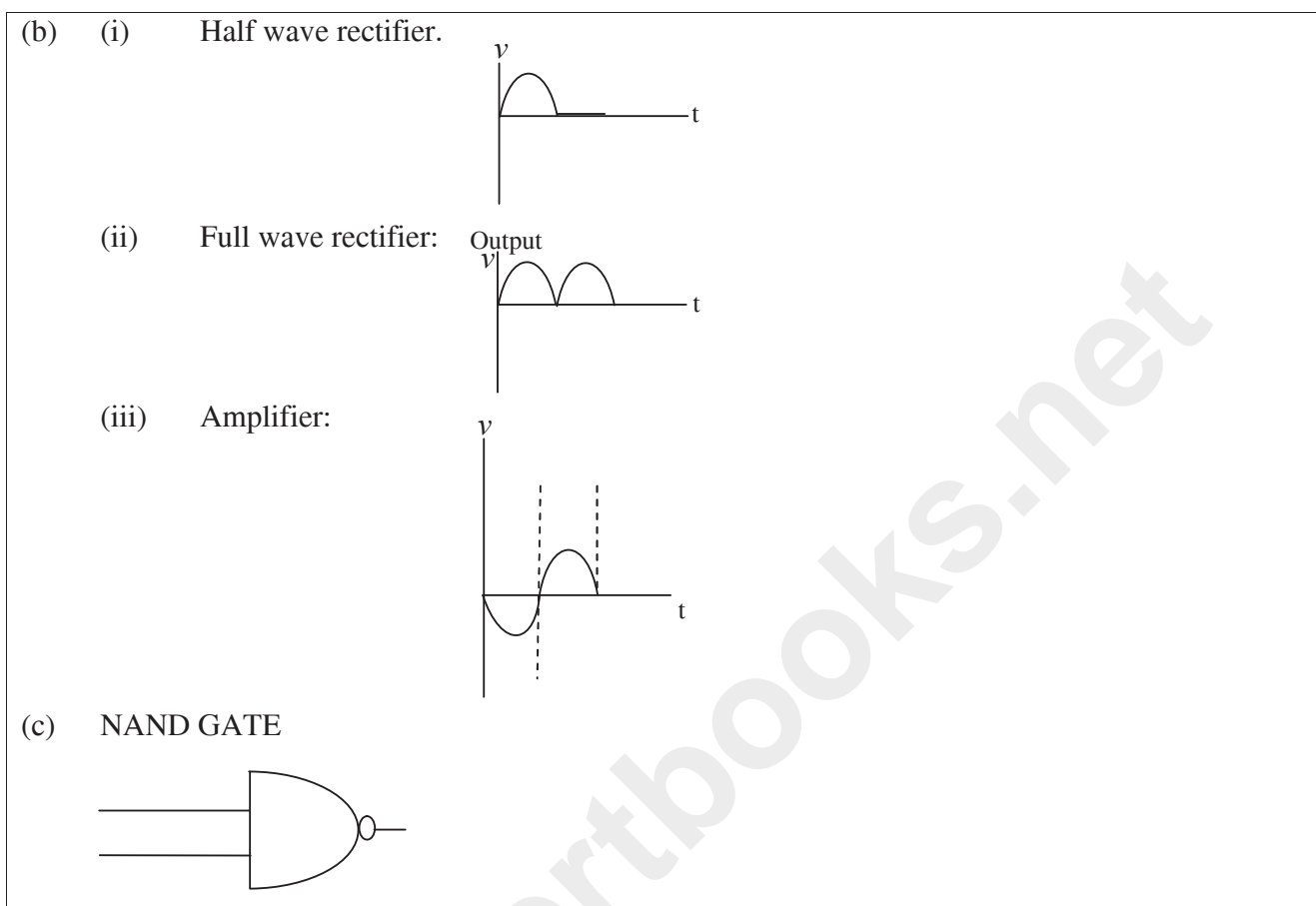

GENERAL COMMENTS:

(a) Topics found difficult by candidates in the Question Paper:

- Correct application of Gauss' law
- Distribution of charge in a network of capacitors.
- Vector form of Biot-Savart Law
- RLC Circuit, voltage across each; $X_c = 1/\omega C$ calculation
- Kirchhoff's Law equations
- Solving simultaneous equations
- Direction of induced current; Lenz's law.
- Derivations: Mixed grouping of cells, Magnetic force between parallel currents, Interference fringe-width formula, and Chromatic aberration formula.
- Relation between angles in the refraction through a prism, including critical angle.
- Compound microscope, ray diagram, magnifying power.
- Particle accelerators.
- Significance of BE/A and negative total energy.

- Conversion of energy into matter; examples.
- Modulation

(b) Concepts between which candidates got confused:

- Permittivity and relative permittivity.
- Seebeck effect and Peltier effect.
- Electric and magnetic dipole moments.
- Relative size and focal length of objective and eyepiece in a telescope.
- Long sightedness and short sightedness.
- Polarised light and un-polarised light in terms of electric field vector.
- Emission of photons from (i) H atom (Bohr's theory) and (ii) metals (photo-electric effect).
- Wave nature and particle nature.
- Mass defect, binding energy, energy released, and conversion factor ($1 \text{ u} = 931.5 \text{ MeV}$).
- The n-type and p-type semiconductors.
- Amount of radioactive substance decayed/left.

(c) Suggestions for students:

- While reading your text, mark important definitions, formulas, vector equations and make a list.
- Prepare notes combining your own reading and class room lecture material. Review the classroom lessons on the same day.
- Learn derivations step by step, understanding the logic of each step; start from defining equations or the given equations. Include diagrams if relevant.
- Work out as many problems as possible related to each topic.
- Practise drawing figures, graphs and circuit diagrams with labels.
- Keep your eyes/mind open for easier, shorter, and faster solutions/derivations.
- Read each question very carefully, underline the data given (if any), and plan out the steps, solution and results **exactly as required in the question**.
- Do not leave out units of final results, and arrows in ray diagrams.
- Try to understand what exactly is asked; do just that and that only.
- Keep your answers neat, legible and well-spaced.
- Keep the length of your answers proportional to the marks allotted.
- Do not copy diagrams, tables etc. from the question paper.
- Practice drawing figures, graphs and circuit diagrams with labels.
- Work systematically, with a definite plan of study and revision.