

ICSE 2025 EXAMINATION

Sample Question Paper - 8

Physics

Time: 2 Hours.

Total Marks: 80

General Instructions:

1. Attempt **all** questions from **Section A** and **any four** questions from **Section B**.
 2. The intended marks of questions or parts of questions are given in brackets [].
-

SECTION A

(Attempt **all** questions from this Section)

Question 1

[15]

Choose the correct answers to the questions from the given options. (Do not copy the questions, write the correct answer only.)

- i) What is the product of force and the time for which force acts known?
 - (a) Momentum
 - (b) Acceleration
 - (c) Inertia
 - (d) Impulse of Force
- ii) A force of 16 N acts on a body of mass 90 kg for two minutes. If the body is initially at rest, the final velocity of it is:
 - (a) 20.36 m/s
 - (b) 21.36 m/s
 - (c) 22.36 m/s
 - (d) 23.36 m/s
- iii) The series of energy inter-conversions in a steam engine is
 - (a) Chemical energy > Heat energy > Potential Energy
 - (b) Chemical energy > Heat energy
 - (c) Chemical energy > Heat energy > Kinetic Energy
 - (d) Chemical energy > Kinetic Energy
- iv) Name the process in which two light nuclei combine to form a heavy nucleus.
 - (a) Radioactivity
 - (b) Transmutation
 - (c) Fission reaction
 - (d) Fusion reaction

- v) A ray of light passing through a principal focus or appearing to meet at the principal focus, after refraction, will emerge:
- (a) Parallel to the principal focus
 - (b) Parallel to the principal axis
 - (c) Perpendicular to the principal focus
 - (d) Perpendicular to the principal axis
- vi) To reflect sound waves from any surface, it should have dimensions
- (a) Equal or less than the wavelength of the sound wave
 - (b) Equal or greater than the wavelength of the sound wave
 - (c) Always greater than the wavelength of sound wave
 - (d) Always less than the wavelength of sound wave
- vii) What is the safe limit of sound level in dB for our ears?
- (a) Up to 120 dB
 - (b) Up to 12 dB
 - (c) Up to 1200 dB
 - (d) Up to 240 dB
- viii) **Assertion (A):** Deviation of light rays occurs only at the first surface of the prism.
Reason (R): A prism does not produce colours but splits into various colours present in the light incident on it.
- (a) both A and R are true and R is the correct explanation of A.
 - (b) both A and R are true and R is not the correct explanation of A.
 - (c) Assertion is false but reason is true
 - (d) Assertion is true reason is false
- ix) When 1 coulomb of charge moves against a potential difference of 1 volt, how much work is done?
- (a) 1 joule
 - (b) 2 joule
 - (c) 0.5 joule
 - (d) 1.5 joule
- x) A bulb is rated as 270V, 0.5 A. Its power is
- (a) 125 watt
 - (b) 100 watt
 - (c) 60 watt
 - (d) 135 watt

- xi) A charged particle enters a uniform magnetic field, parallel to the field, its kinetic energy:
- Increases
 - Decreases
 - Remains constant
 - Becomes zero
- xii) The latent heat of the fusion of ice is 80 cal/g. The heat required to melt 2g of ice is:
- 40 cal
 - 80 cal
 - 160 cal
 - 120 cal
- xiii) Ocean currents carry icebergs over very long distances due to:
- high specific heat capacity of water
 - high specific latent heat of vapourisation of water
 - high specific latent heat of fusion of ice
 - low specific latent heat of fusion of ice
- xiv) The colour which deviates most in the formation of the spectrum of white light by a prism is
- Red
 - Green
 - Violet
 - Yellow
- xv) The nature of the image formed by the concave lens is always:
- Real and inverted
 - Real and erect
 - Virtual and erect
 - Virtual and inverted

Question 2

(i)

- The basic principle of a nuclear bomb is based on _____ [Uncontrolled chain, Controlled chain, fusion] reaction.
- _____ [Electric current/ Electric potential /Electric Power] is defined as the amount of work done in bringing a unit positive charge from infinity to that point.
- _____ [Class I/Class II/Class III] lever is used as a force multiplier.
- Mechanical advantage = _____. $\left[\frac{\text{Load}}{\text{effort}} / \frac{\text{effort}}{\text{Load}} / \frac{\text{Work output}}{\text{Work Input}} \right]$

- (e) A fuse is a short piece of wire of material of _____ [high conductivity/high resistivity, low resistivity/low conductivity] and _____ [Low melting point/high melting point].
- (ii) The work done by the heart is 1 joule per beat. Calculate the power of the heart if it beats 72 times in one minute. [2]
- (iii) Mention two properties of a wave—one property which varies and the other which remains constant when the wave passes from one medium to another. [2]

Question 3

- (i) [3]
- (a) Why is less effort needed to lift a load over an inclined plane as compared to lifting the load directly?
- (b) One isotope of uranium has a mass number of 235 and an atomic number of 92.
1. What is the number of electrons in the neutral atom of this isotope?
 2. What is the number of protons and neutrons in its nucleus?
- (ii) State any two properties which are common to both the beta rays and cathode rays. [2]
- (iii) Name any two electromagnetic waves with a frequency higher than violet light. State one use of each. [2]
- (iv) State two ways by which the frequency of transverse vibration of a stretched string can be decreased. [2]
- (v) Why does the temperature of the surroundings start falling when the ice of a frozen lake starts melting? [2]
- (vi) Four resistors of 2.0Ω each are joined end to end to form a square ABCD. Calculate the equivalent resistance of the combination between any two adjacent corners. [2]
- (vii) Why is the earth pin made longer and thicker than the other two pins in a three-pin plug? [2]

Question 5

- i) An object 10 cm long is placed at 15 cm from a convex lens of focal length 10 cm. [3]
(a) Find the position and size of the image.
(b) If the focal length of a lens is
(1) Positive
(2) Negative
In each case, state the kind of lens.
- ii) [3]
(a) What is a spectrum?
(b) Why is white light considered to be poly chromatic in nature?
(c) Give the range of the wavelength of those electromagnetic waves which are visible to us?
- iii) A ray of light is normally incident on one face of an equilateral glass prism [4]
(a) What is the angle of incidence on the first face of the prism?
(b) What is the angle of refraction from the first face of the prism?
(c) What do you understand by the term spectrum?
(d) Out of red light, violet light, yellow light and green light, which light has the maximum shift?

Question 6

- i) [3]
(a) Give two reasons why the efficiency of a single movable pulley is not 100%.
(b) What do you mean by equilibrium of a body?
(c) State the S.I unit of force.
- ii) [3]
(a) A body of mass 2 kg is thrown vertically upwards with an initial velocity of 20 m/s.
What will be its potential energy at the end of 2 s?
A boy weighing 42 kg makes a high jump of 1.5 m.
(b) What is his kinetic energy at the highest point?
(c) What is his potential energy at the highest point? ($g = 10 \text{ m/s}^2$)
- iii) Ajit, an engineer, is designing a new roller coaster for an amusement park. The roller coaster has a loop-the-loop section as shown below, where the cars travel upside down. He needs to ensure that the passengers remain safely in their seats even when they are upside down. [4]

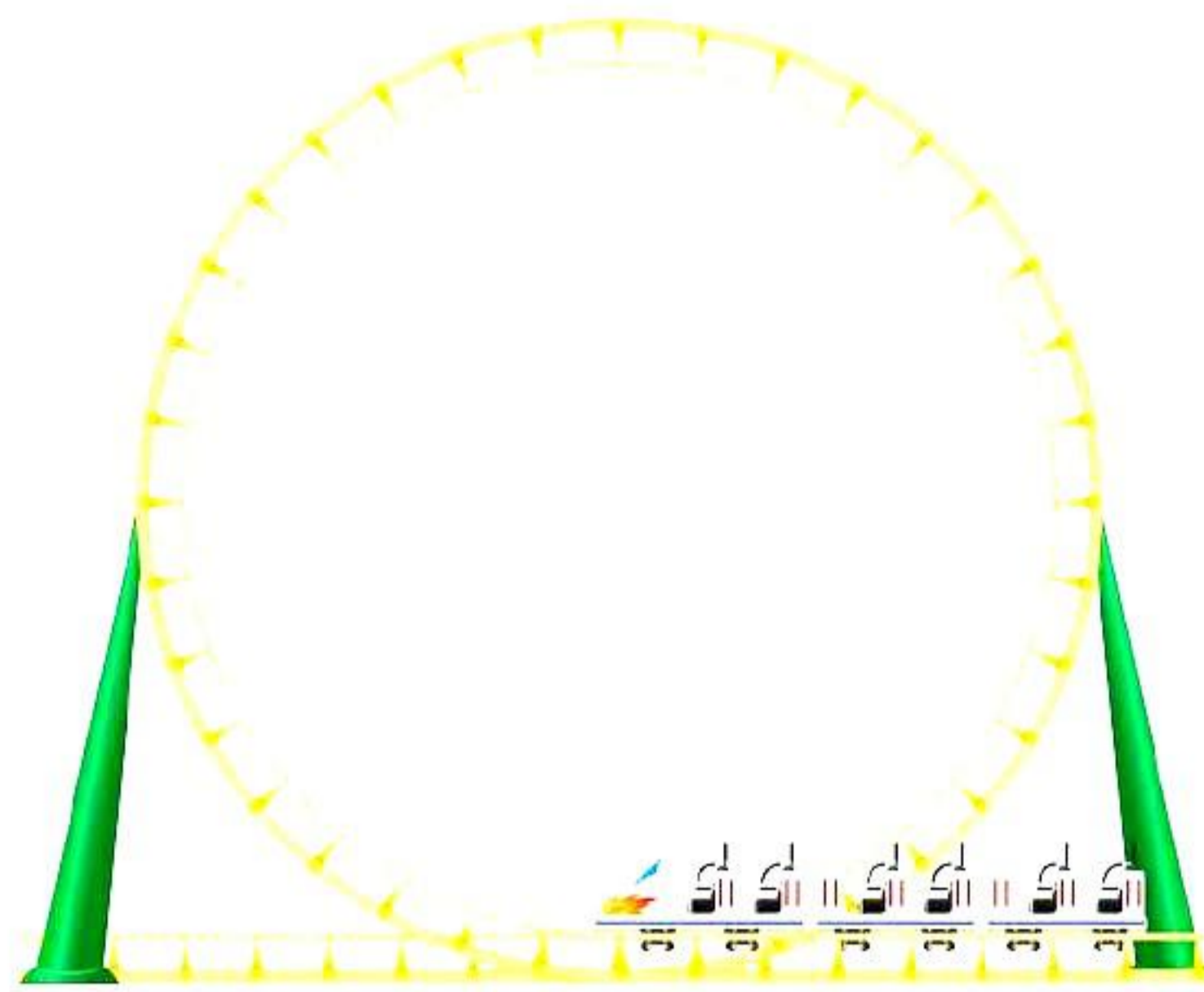

- i. For the given case, what provides the necessary force that keeps the passengers moving along the circular loop-the-loop section?
- ii. What factors Ajit needs to consider while designing the roller coaster so that the passengers remain safely in their seats even when they are upside down? Assume that the all the passengers are seated properly supported with the help of seat seatbelts.
- iii. What would happen if the roller coaster car were to slow down too much while going through the loop-the-loop section?
- iv. How does the centripetal force differ from a centrifugal force with reference to the direction in which they act? Give the direction of centripetal and centrifugal force when the cars are upside down with the help of diagram.

Question 7

- i) [3]
 - (a) Define moment of force and state its SI unit. A mechanic can open a nut by applying a force of 150 N while using a lever handle of length 40 cm.
 - (b) For the give case what will be the magnitude of moment of force required to open a nut?
 - (c) A body of mass 1 kg initially at rest is moved by a horizontal force of 0.5 N on a smooth frictionless table. Calculate the work done by the force in 10 s.
- ii) Study the potential difference v/s current graph given below and answer the following questions: [3]

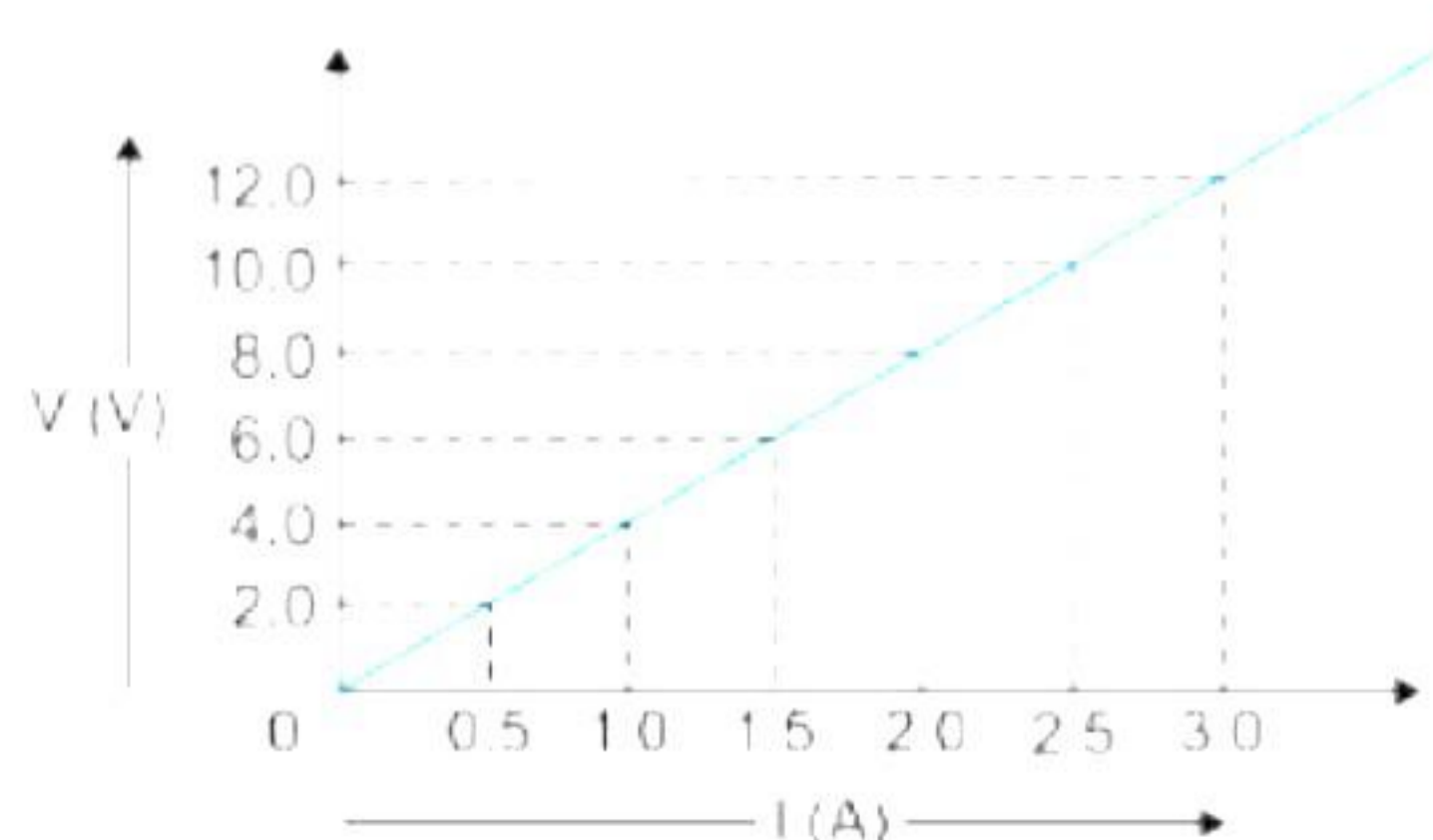

- (a) What is the nature of the graph? What is the relation between V and I?
 (b) Calculate the resistance of the conductor using graph.

iii) The diagram given below represents the magnetic field lines along the axis of a current carrying solenoid. Answer the following questions: [4]

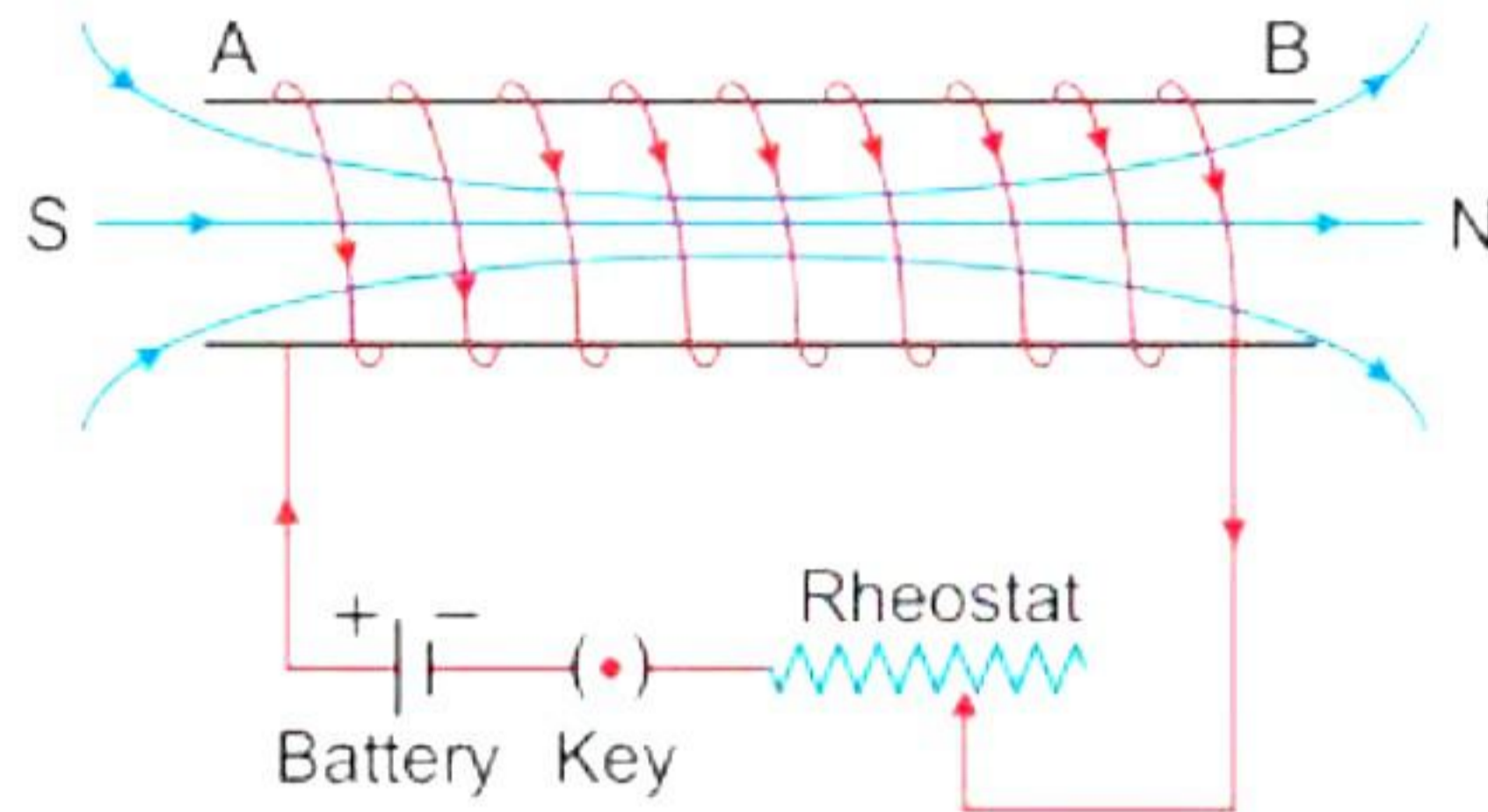

- (a) How is the field strength at all points in case of uniform magnetic field?
 (b) How does the magnetic field vary inside a solenoid?
 (c) Which magnet is the strongest?
 (d) Which magnet produces field lines similar to those produced around a current-carrying solenoid?

Question 8

i) [3]

(a) Define the following terms:

- (1) α -particle
- (2) β -particle

(b) A radioactive nucleus undergoes a series of decays according to the sequence:

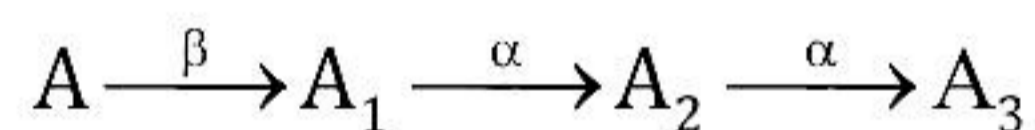

If the mass number and atomic number of A_3 are 172 and 69, respectively, what is the mass number and atomic number of A?

(c) State one use and one harmful effect of radioactivity.

ii) [3]

(a) What is Einstein's mass energy equivalence?

(b) A mass of lead is embedded in a block of wood. Radiations from a radioactive source incident on the side of block produce a shadow on a fluorescent screen placed beyond the block. The shadow of wood is faint, but the shadow of lead is dark.

- 1) Give reason for this difference.
- 2) If the block of wood is replaced by a block of aluminium, will there be any change in the shadow?

- iii) [4]
An electric appliance of resistance 20 ohm and a resistance of 6 ohm are connected in series with 12 V battery.

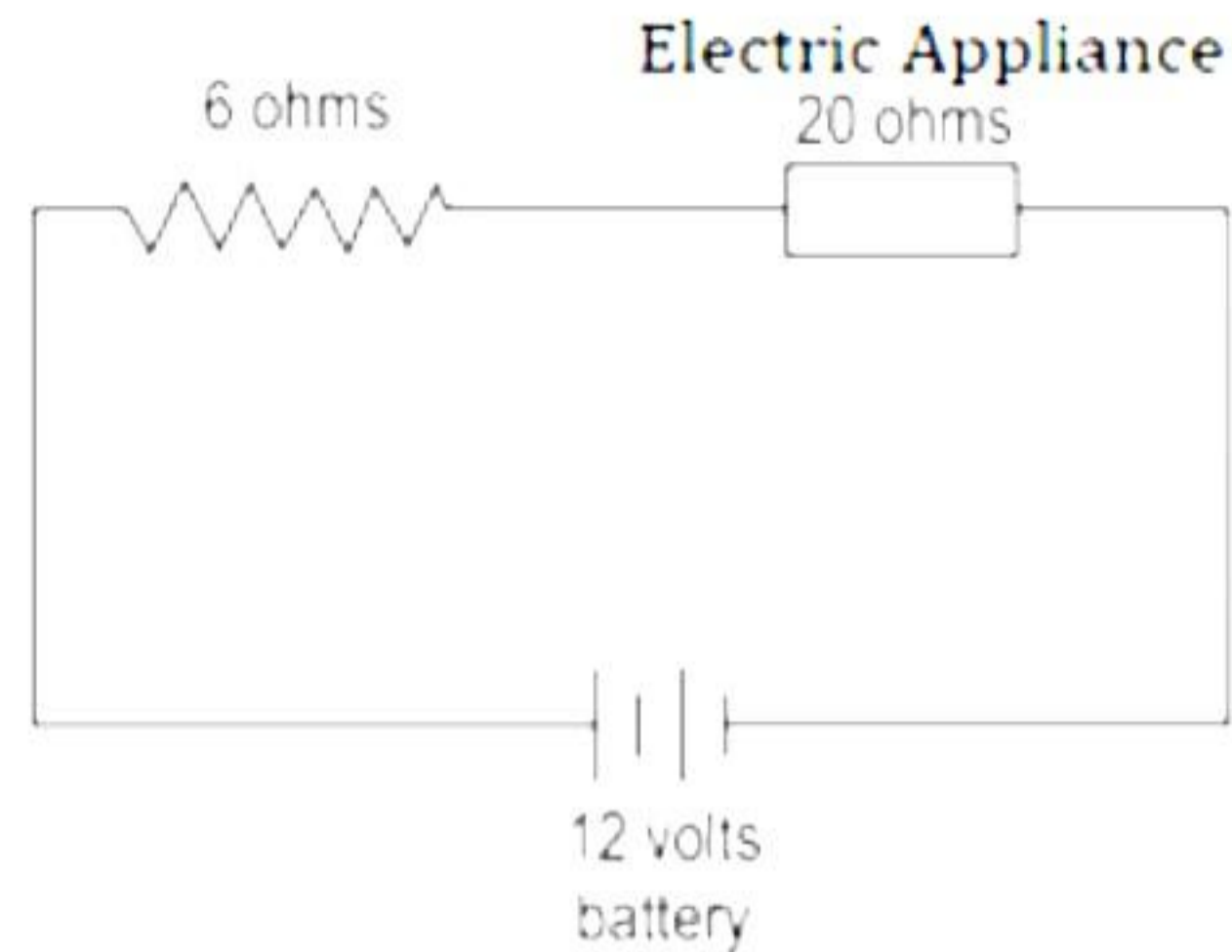

- (a) Calculate the total resistance of circuit.
(b) Find the total current in the circuit.
(c) What is the potential difference across the resistance wire of 6 ohms.
(d) Calculate the potential difference across the electrical appliance.

Question 9

- i) [3]
(a) What are isobars?
(b) Give an example of isobars.
(c) State two differences between a chemical change and a nuclear change.
- ii) [3]
(a) Two friends were playing on identical guitars whose strings were adjusted to give notes of the same pitch. Will the quality of the two notes be same? Give a reason for your answer.
(b) The wavelength of sound emitted by a source is 1.7×10^{-2} m. Calculate the frequency of sound if its velocity is 343.4 m/s.
- iii) [4]
A person standing between two vertical cliffs, 660 m from the nearest cliff, produces sound. He hears the first echo after 5 seconds and the second echo 3 seconds later.
A person stands between two vertical cliffs, 660 meters away from the closest one, and makes a sound. The first echo reaches them after 4 seconds, followed by the second echo 2 seconds later.

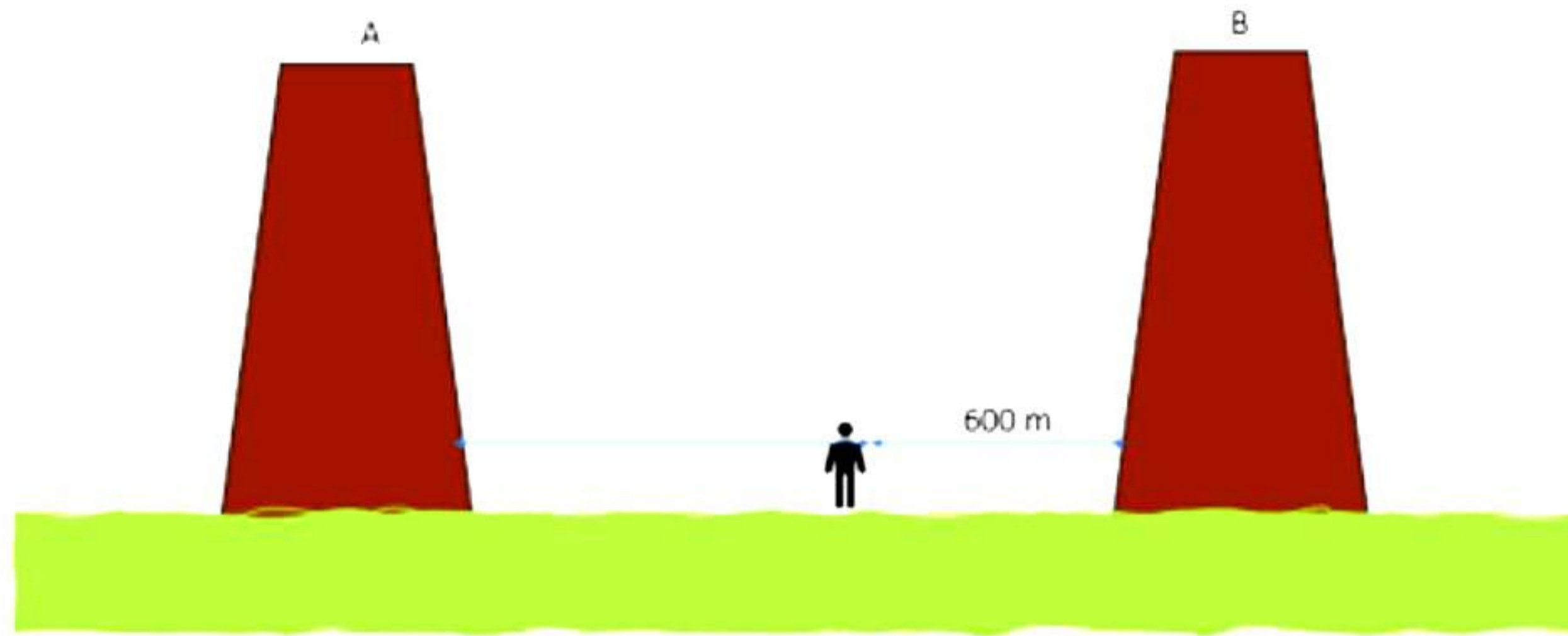

Answer the following questions based on the given information.

- (a) Calculate the speed of sound in air.
- (b) Find the distance between man and cliff A.
- (c) Find the distance between cliff A and B.
- (d) If man stands exactly between two cliffs, what will be the the time period after which the echo is heard?

Solution

Section A

Solution 1

- i) Correct option – d: Impulse of force

The impulse of force is the product of force and time.

- ii) Correct option – b: 21.36 m/s

$F = 16 \text{ N}$; $m = 90 \text{ kg}$; $t = 120 \text{ s}$; $u = 0$; $v = ?$

$$v = u + \frac{F}{m}t$$
$$= 0 + \frac{16}{90} \times 120$$
$$= 21.36 \text{ m/s}$$

- iii) Correct option – c: Chemical energy \rightarrow Heat energy \rightarrow Kinetic Energy

Chemical energy \rightarrow Heat energy \rightarrow Kinetic Energy is a series of energy inter conversions in steam engines.

- iv) Correct option – d: Fusion reaction

Fusion reaction is the process in which two light nuclei combine to form a heavy nucleus.

- v) Correct option – b: Parallel to the principal axis

A ray of light passing through a principal focus or appearing to meet at the principal focus will emerge parallel to the principal axis after refraction.

- vi) Correct option – b: Equal or greater than the wavelength of the sound wave

To reflect sound waves from any surface, it should have dimensions equal to or greater than the wavelength of the sound wave.

- vii) Correct option – a: Up to 120 dB

The safe limit of sound level in dB for our ears is up to 120 dB

- viii) Correct option – c: Assertion is false but reason is true.

Dispersion of white light occurs only at the first surface of a prism, while deviation occurs at both the prism's surfaces.

- ix) Correct option – a: 1 joule
When 1 coulomb of charge moves against a potential difference of 1 volt, then 1 Joule of work is done.
- x) Correct option – d: 135 watt
 $V = 270 \text{ V}, I = 0.5 \text{ A}$
 $P = V \times I = 270 \times 0.5 = 135 \text{ watt}$
- xi) Correct option – c: remains constant.
A charged particle enters a uniform magnetic field parallel to the field; its kinetic energy remains constant.
- xii) Correct option – c: 160 cal
Here, $m = 2 \text{ g}; L = 80 \text{ cal/g}$
Heat required = $mL = 2 \times 80 = 160 \text{ cal}$
- xiii) Correct option – c: high specific latent heat of fusion of ice
Ocean currents carry icebergs over very long distances due to the high specific latent heat of fusion of ice (i.e. 3360000 J/kg).
- xiv) Correct option – c: Violet
The colour which deviates most in forming the spectrum of white light by a prism is violet.
- xv) Correct option – c: virtual and erect
The nature of the image formed by the concave lens is always virtual and erect.

Solution 2

- (i)
- (a) Uncontrolled chain
The basic principle of a nuclear bomb is based on uncontrolled chain reaction.
- (b) Electric potential
Electric Potential is defined as amount of work done in bringing a unit positive charge from infinity to that point.
- (c) Class II
A lever of the second type (or class II) is used as a force multiplier. In second class lever, the effort arm is always longer than the load arm and so its mechanical advantage is always greater than 1.
- (d) Load/ Effort
M.A : It is the ratio of the load to the effort.
$$M.A. = \frac{\text{Load}}{\text{Effort}}$$

(e) High resistivity, low melting point

A fuse is a short piece of wire of material of high resistivity and low melting point.

(ii) Work done in 1 beat = 1 J

Work done in 72 beats = 72 J

Time in which work is done, $t = 60$ s

$$\therefore \text{Power} = \frac{\text{Work done}}{\text{time taken}} = \frac{72}{60} = 1.2 \text{ W}$$

(iii) The two properties of a wave are wavelength and frequency. The wavelength of a wave changes when a wave passes from one medium to another, and the frequency of a wave remains constant when it passes from one medium to another.

Solution 3

(i)

(a) For an object resting on an inclined plane, the vertical force of gravity acting on it is split into two smaller forces; one perpendicular to the plane and one parallel to the plane. Only the parallel force needs to be counter acted by pushing, ignoring friction.

The slope provides "mechanical advantage" as a simple machine.

(b)

1. Given that,

$$A = 235,$$

$$Z = 92$$

Now,

$$\text{Atomic Number } Z = \text{number of protons} = \text{number of electrons} = 92$$

\therefore The neutral atom of ${}_{90}^{235}\text{U}$ will have 92 electrons.

2. The number of protons = $Z = 92$

$$\text{The number of neutrons} = A - Z = 235 - 92 = 143.$$

(ii) Common properties of beta rays and cathode rays:

(a) Both are negatively charged with charge and mass equal to that of an electron.

(b) The electric and magnetic fields deflect both.

(c) Both cause fluorescence on striking a fluorescent material.

(iii) Two electromagnetic waves whose frequencies are higher than those of violet light are

(a) Ultraviolet radiation

Use: In the treatment of skin disorders and for killing bacteria

(b) X-rays

Use: In radiography and for detecting flaws in metals

(iv) The frequency of transverse vibration of a stretched string can be decreased by

2. Decreasing the tension in the string
3. Increasing the length of the string

(v) Ice has a high specific latent heat of fusion of 336,000 J/kg. Thus, when the ice of the frozen lake starts melting, it absorbs a large amount of heat energy from the surroundings. This leads to a decrease in the surrounding temperature.

(vi)

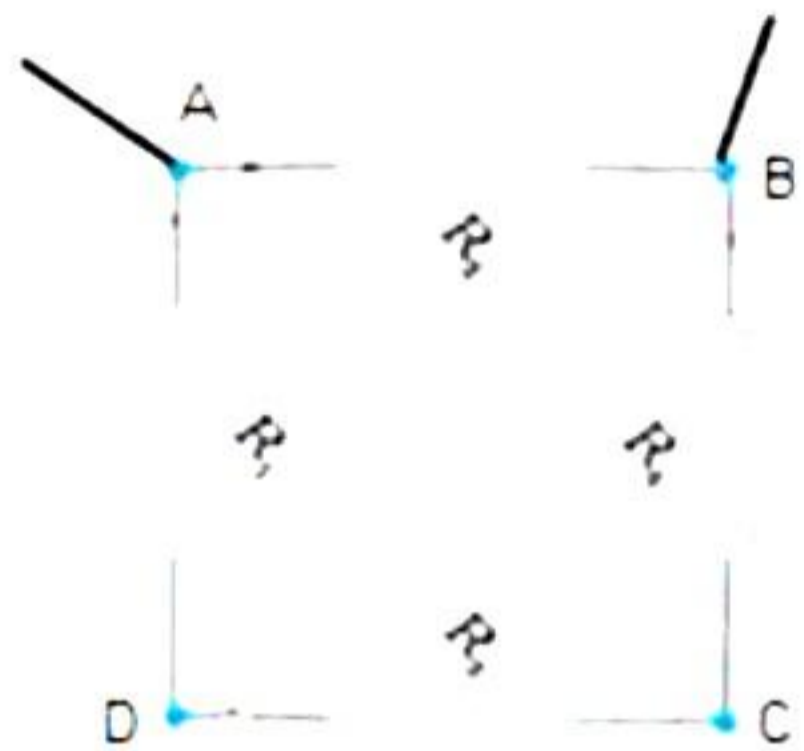

Resistances $R_1 = R_2 = R_3 = R_4 = 2\Omega$ are connected, as shown in the diagram above. Between A and B, the series combination of resistors R_1 , R_3 and R_4 is connected in parallel with R_2 . Total resistance between A and B = R_{AB} .

Then

$$\frac{1}{R_{AB}} = \frac{1}{2} + \frac{1}{6} = \frac{3+1}{6} = \frac{4}{6}$$

$$R_{AB} = 1.5 \Omega$$

(vii) The earth pin is long so that the earth connection is made first. This ensures the user's safety because if the appliances are defective, the fuse will blow off. The earth pin is made thicker so that even by mistake, it cannot be inserted into the hole for a live or neutral connection of the socket.

SECTION B

Solution 4

i)

(a) BC indicates partly refracted ray.

(b) BC' indicates partly reflected ray.

(c) A critical angle is the angle of incidence in the denser medium corresponding to which the angle of refraction in the rarer medium is 90° . In the above given case, critical angle, $c = 48^\circ$

ii)

(a)

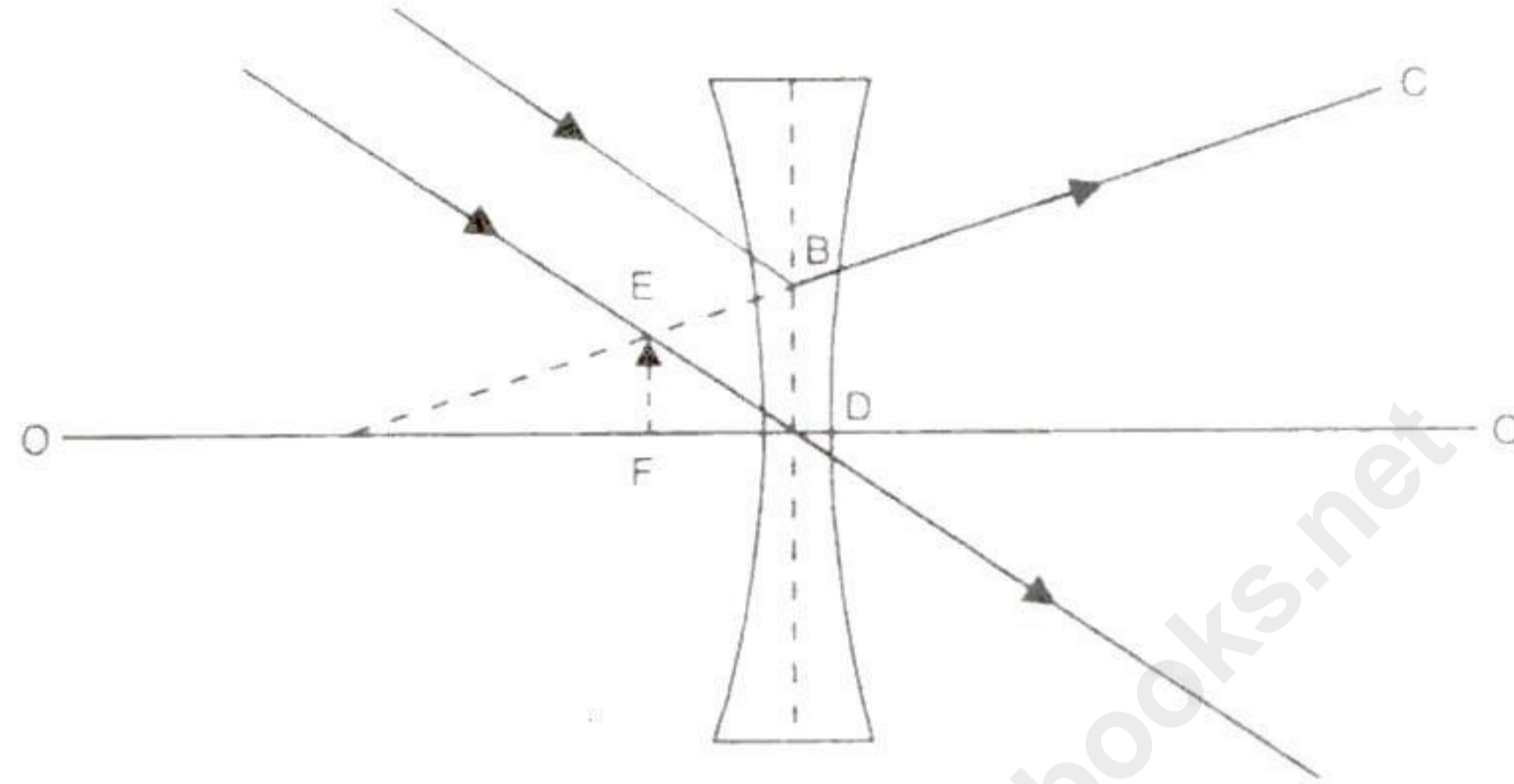

(b) This is due to the unequal refraction of rays diverging from the lower and upper ends of the sun. Rays from the lower edge have to go through a greater thickness of air than rays from the upper edge. So the vertical diameter appears to be diminished in size, whereas the horizontal diameter remains unaltered.

(c) Yes, the rays from the virtual image are divergent after reflection but they can be converged on to a photographic plate by the lens of the camera, forming a real image.

iii)

(a) $\mu = 1.5$;

$i = 30^\circ$

$$\text{Now, } \mu = \frac{\sin i}{\sin r}$$

$$\text{Or } \sin r = \frac{\sin i}{\mu} = \frac{\sin 30^\circ}{1.5} = \frac{0.5}{1.5} = 0.3333$$

$$r = 19.45^\circ$$

Also, speed of light in glass

$$v = \frac{c}{\mu} = \frac{3 \times 10^8}{1.5} = 2 \times 10^8 \text{ ms}^{-1}$$

(b)

Convex lens	Concave lens
Convex lenses are called converging lenses because they cause parallel rays to converge.	Concave lenses are called diverging lenses because they cause parallel rays to diverge.
A convex lens is thicker at the centre than at the edge. It magnifies or makes things look larger.	A concave lens is thinner in the middle and thicker at the edge.
A convex lens can only form a virtual image because the parallel rays passing through the lens bend towards one another.	A concave lens can form both virtual and real images because the parallel rays passing through the lens spread as they leave the lens.
It has a real focus.	It has a virtual focus.
Examples: Lenses of the human eye, camera, microscope, and telescope.	Examples: Lenses of laser lights, binoculars and flashlights.

Solution 5

i)

(a) Given that,

$$h_1 = 10\text{cm}$$

$$u = -15\text{cm}$$

$$f = +10\text{cm}$$

$$\frac{1}{v} - \frac{1}{u} = \frac{1}{f}$$

$$\frac{1}{v} = \frac{1}{u} + \frac{1}{f} = \frac{1}{10} - \frac{1}{15} = \frac{1}{30}$$

$$v = 30\text{cm}$$

$$\frac{-h_2}{h_1} = \frac{v}{u}$$

$$h_2 = \frac{-30}{15} \times 10 = -20\text{cm}$$

(b) (1) convex (2) concave

ii)

(a) The band of colored components of a light beam is called a spectrum. Visible spectrum is obtained when a beam of white light passes through prism. The spectrum appears to be continuous as each colour blends in to the subsequent colour.

(b) Poly chromatic light consists of many colors each having its characteristic wavelength. White Light is polychromatic light because white light is made up of seven colours.

(c) 780 nm-400nm, (7800Å-4000 Å)

iii)

(a) 0°

(b) 0°

(c) On passing white light through the prism, the band of colours seen on the screen is called the spectrum.

(d) Violet light

Solution 6

i)

(a) Due to

- Friction in the pulley bearings or at the axle.
- The weight of the pulley and string, the effort needed to lift a load L will be more than $\frac{L}{2}$, so the mechanical advantage will be less than 2. Since the velocity ratio will remain 2.

Hence, efficiency will be less than 100%.

- (b) When a number of forces acting on a body produce no change in its state of rest or of linear or rotational motion, the body is said to be in equilibrium.
- (c) S.I unit of force is Newton.

ii)

- (a) Height gained by the body in 2 seconds is

$$s = ut + \frac{1}{2}at^2$$

$$h = 20 \times 2 + \frac{1}{2}(-10)(2^2)$$

$$h = 20\text{m}$$

$$\text{PE} = mgh$$

$$\text{PE} = 2 \times 10 \times 20$$

$$\text{PE} = 400\text{Joules}$$

- (b) At the highest point, the velocity of the body would become zero. As a result, kinetic energy at the highest point is zero.

- (c) Given that,

$$M = 42 \text{ kg}$$

$$h = 1.5 \text{ m}$$

Now, Potential energy at the highest point = mgh

$$\text{PE} = 42 \times 10 \times 1.5$$

$$\text{PE} = 630 \text{ joules}$$

iii)

- i. For the given case, the force that keeps the passengers moving along the circular loop-the-loop section is provided by the normal force exerted by their seats on their bodies. This normal force acts as the centripetal force that keeps the passengers moving in a circular path without falling.
- ii. Amit needs to design the roller coaster so that there is enough centripetal force always acting on each passenger to keep them safely in their seats even when they are upside down. This can be achieved by ensuring that there is enough normal force always exerted by their seats on their bodies.
- iii. If the roller coaster car slows down too much while going through the loop-the-loop section, there may not be enough centripetal force on each passenger to keep them safely in their seats. As a result, they could potentially fall out of their seats.
- iv. Both centripetal and centrifugal force will act in opposite direction.

i.e., When the cars are upside down the centripetal force will be along the centre of loop the loop and the centrifugal force will be along the direction away from centre as shown below.

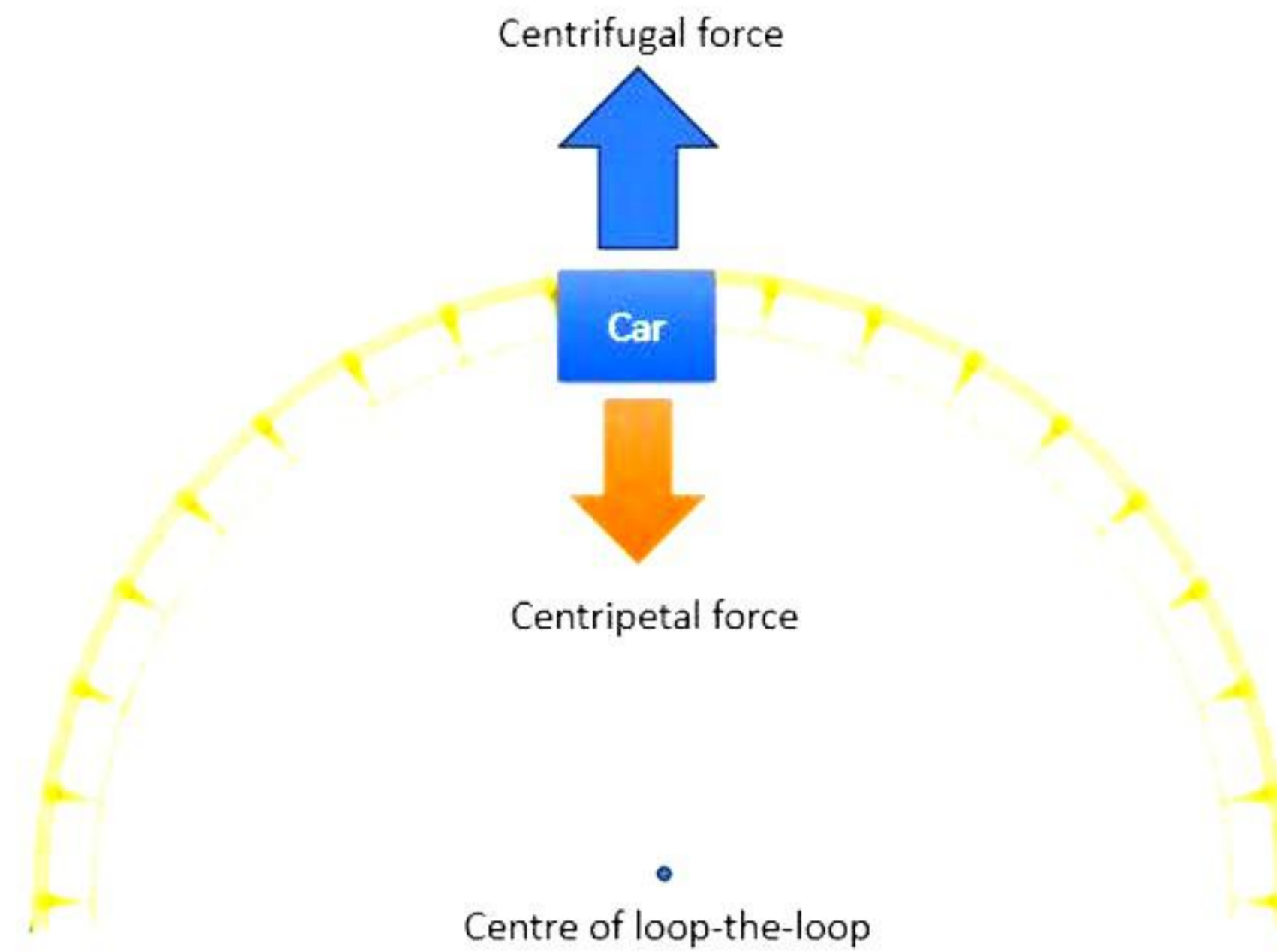

Solution 7

i)

(a) The turning effect produced by a force on a rigid body about a point, pivot or fulcrum is called the moment of force or torque. The SI unit of moment of force is newton meter (Nm).

(b) In the first case $F = 50\text{ N}$, $r = 40\text{cm} = 0.4\text{m}$

The moment of force needed to open the nut = $150\text{ N} \times 0.4\text{m} = 60\text{Nm}$

(c) Work done.

$$W = FS = 0.5 \times 25 = 12.5\text{J}$$

ii)

(a) It is a straight-line graph.

The relation between voltage and current can be expressed as

$$V \propto I \Rightarrow V = IR$$

(Here, R is constant also known as resistance according to Ohm's law)

(b) Consider one reading of potential difference and the corresponding value of current.

From the graph,

$$\text{For } V = 8\text{ V}, I = 2\text{ A}$$

Thus, by substituting the value of V and I we get,

$$V = IR$$

$$R = V/I = 8/2 = 4\ \Omega$$

iii)

(a) The magnetic field strength in case of uniform magnetic field is same at all points.

(b) Inside the solenoid, the magnetic field remains uniform.

- (c) An electromagnet is the strongest one.
 (d) The field lines around a current-carrying solenoid are similar to that produced by a bar magnet.

Solution 8

i)

(a)

1. An α particle is a helium nucleus. Thus, the α particle carries twice the positive charge of proton and is four times as heavy.
2. β -Particle is an electron of nuclear origin.

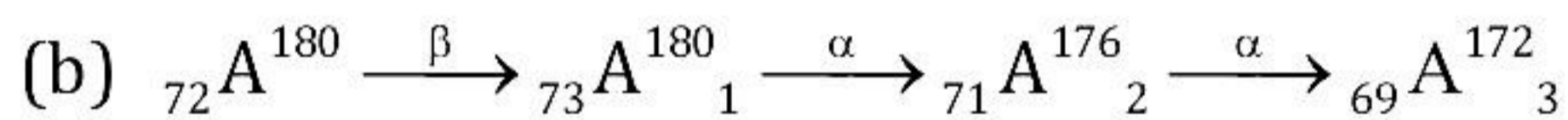

- (c) Use: The radiations are used to cure some disease like cancer.
 Harmful effect: The radiations can damage the living tissues.

ii)

(a) Einstein suggested that mass and energy are interchangeable. Because of loss in mass

Δm , energy released is E ,

Where,

$$E = \Delta mc^2$$

Δm is loss in mass in kg, c is speed of light and E is energy in joule.

(b)

- 1) The shadow of wood is faint because only the α -radiations are stopped by wood (since α -radiations are least penetrating). The shadow of lead is dark because β and γ -radiations are also stopped by lead.
- 2) If wood is replaced by aluminum (or any other light metal), the shadow of aluminum block will remain faint because aluminum will not stop the γ -radiations.

iii)

(a) Total resistance of the circuit, $R_t = 6 + 20 = 26 \Omega$.

(b)

Current,

$$I = \frac{V}{R} = \frac{12}{26} = 0.46 \text{ A}$$

(a) In series, current flowing through resistances is same.

Therefore, potential difference across resistance wire $V_r = 0.46 \times 6 = 2.76 \text{ V}$

(b) Potential difference across an electrical appliance would be,

$$V_{\text{appliance}} = I R_{\text{appliance}}$$

$$\rightarrow V_{\text{appliance}} = 0.46 \times 20 = 9.2 \text{ V}$$

Solution 9

i)

(a) Isobars are two nuclei having the same atomic number Z but different mass numbers.

(b) Examples:

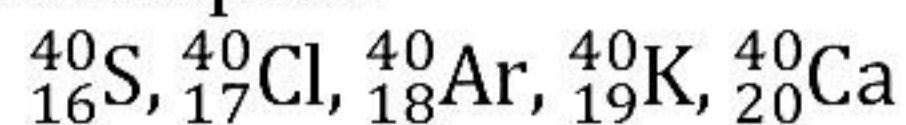

(c)

- A chemical change is due to changes in orbital electrons, while a nuclear change is due to changes in nucleons inside the nucleus.
- Nuclear change requires much more energy than chemical change.

ii)

(a) No, because both the guitars emit the same fundamental note but the subsidiary notes will not be exactly same due to which the waveforms of the two guitars will be different, so they will differ in quality.

(b)

$$v = f \times \lambda$$

$$v = 343.4 \text{ ms}^{-1}$$

$$f = ?$$

$$\lambda = 1.7 \times 10^{-2}$$

$$343.4 = f \times 1.7 \times 10^{-2}$$

$$f = \frac{343.4}{1.7 \times 10^{-2}}$$

$$f = 2.02 \times 10^4 \text{ Hz}$$

iii)

(a) Given that,

The distance between cliff B and man, $d_1 = 660 \text{ m}$

Time period, $T_1 = 4 \text{ sec}$

Now,

Speed of sound in air, $v = 2 \times 660 / 4 = 330 \text{ m/s}$

(b) Given that,

Time period after which second echo was heard, $T_2 = 4 + 2 = 6 \text{ sec}$

Now,

Distance travelled by sound wave in 6 sec, $d_2 = 6 \times 330 = 1980 \text{ m}$

(c) Distance between two cliffs, $d = d_1 + d_2 = 1980 + 330 = 2640 \text{ m}$

(d) Now if person moves exactly between two cliffs the distance between man and either cliff will, $d' = 1320 \text{ m}$

Now,

Time period after which Echo hear, $T' = \frac{2 \times 1320}{330} = 8 \text{ sec}$