

X - ICSE BOARD - 2018

Date: 16.03.2018 Physics - Question Paper Solutions

SECTION - I (40 Marks)

Attempt all questions from this Section

Question 1

- (a) (i) State and define the S.I. unit of power.
(ii) How is the unit horse power related to the S.I. unit of power?

Ans. (i) The rate of doing work is called power.

$$P = \frac{W}{t}$$

S.I. unit of power is Joule/sec also called watt (w)

- (ii) 1 horse power (hp) = 746 watts

(b) State the energy changes in the following cases while in use:

- (i) An electric iron
(ii) A ceiling fan

Ans. (i) Electrical energy into heat energy.
(ii) Electrical energy into mechanical energy.

(c) The diagram below shows a lever in use :

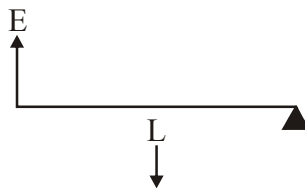

- (i) To which class of levers does it belong?
(ii) Without changing the dimensions of the lever, if the load is shifted towards the fulcrum what happens to the mechanical advantage of the lever?

Ans. (i) It belongs to class-II lever.

(ii) If local is shifted towards the fulcrum.

Mechanical advantage will increase ($M \cdot A > 1$)

(d) (i) Why is the ratio of the velocities of light of wavelengths 4000\AA and 8000\AA in vacuum $1 : 1$?

(ii) Which of the above wavelengths has a higher frequency ?

Ans. (i) In vacuume light or any electromagnetic wave velocity is always constant 3×10^8 m/s and it does not depend on wavelength or frequency.

(ii) As we know $v = n\lambda$, where v = velocity and 'n' is frequency, therefore frequency is inversely proportional to wavelength. therefore wavelength of 4000\AA will have more frequency.

(e) (i) Why is the motion of a body moving with a constant speed around a circular path said to be accelerated ?

(ii) Name the unit of physical quantity obtained by the formula $\frac{2K}{V^2}$.

Where K : kinetic energy, V : Linear velocity.

Ans. (i) In circular motion with constant speed linear velocity changes in terms of direction therefore it is accelerated motion.

(ii) We know that kinetic energy $K.E. = \frac{1}{2}mv^2$

$$\therefore \frac{2K}{V^2} = 2 \left(\frac{1}{2}mv^2 \right) / v^2 = m(\text{mass})$$

\therefore Physical quantity is 'mass'.

Question 2

(a) The power of a lens is $-5D$.

(i) Find its focal length.

(ii) Name the type of lens.

Ans. (i) Given power of lens = $-5D$

focal length (f)

$$f = \frac{1}{d} = \frac{1}{(-5)} = \frac{-1}{5} = -0.2m$$

(ii) As power is negative lens is concave.

(b) State the position of the object in front of a converging lens if :

- (i) It produces a real and same size image of the object.
- (ii) It is used as a magnifying lens.

Ans. (i) To get real and same size image, object is placed at '2F'.
(ii) To be used as magnifying object must be placed between lens and F_1 .

(c) (i) State the relation between the critical angle and the absolute refractive index of a medium.
(ii) Which colour of light has a higher critical angle ? Red light or Green light.

Ans. (i) $\mu = \frac{1}{\sin c}$ or $\sin c = \frac{1}{\mu}$, where 'c' is critical angle and ' μ ' is absolute refractive index.
(ii) Critical angle for 'Red' colour is higher.

(d) (i) Define scattering.
(ii) The smoke from a fire looks white.

Which of the following statements is true ?

1. Molecules of the smoke are bigger than the wavelength of light.
2. Molecules of the smoke are smaller than the wavelength of light

Ans. (i) Scattering is the process of absorption and then re-emission of light energy.
(ii) The smoke from a fire looks white because molecules of the smoke are bigger than wavelength of light, scatter the light off all wavelengths of white light to the same extent.
Therefore, statement-1 is true.

(e) The following diagram shows a 60° , 30° , 90° glass prism of critical angle 42° . Copy the diagram and complete the path of incident ray AB emerging out of the prism marking the angle of incidence on each surface.

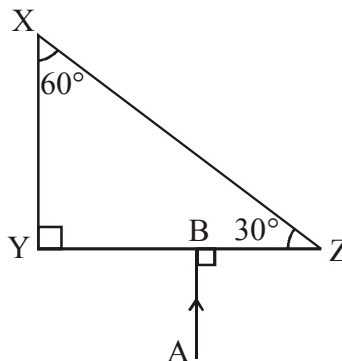

Ans.

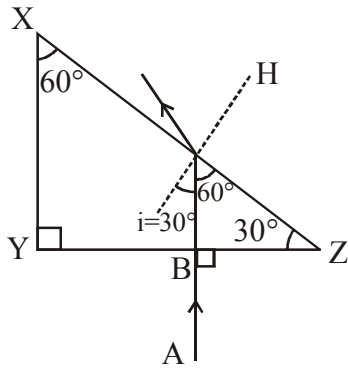

Here ' i ' is less than ' i_c '

Question 3

(a) Displacement distance graph of two sound waves A and B, travelling in a medium, are as shown in the diagram below.

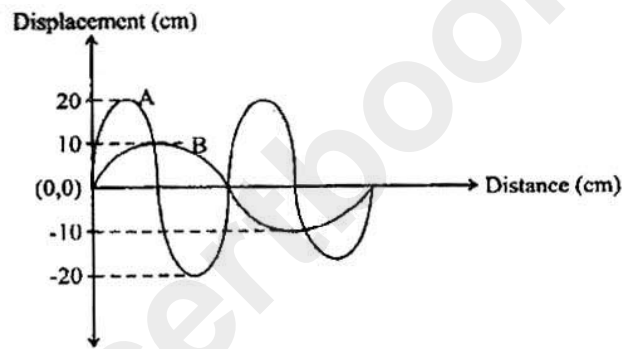

Study the two sound waves and compare their :

- (i) Amplitude
- (ii) Wavelengths

Ans. For sound wave 'B' amplitude is half of amplitude of 'A' similarly wavelength of 'B' is double of wavelength of 'A'.

(b) You have three resistors of values 2Ω , 3Ω and 5Ω . How will you join them so that the total resistance is more than 7Ω ?

- (i) Draw a diagram for the arrangement.
- (ii) Calculate the equivalent resistance.

Ans. To get total resistance more than 7Ω . We can connect 2Ω , 3Ω and 5Ω in series.

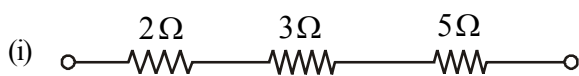

(ii) $R_{\text{equivalent}} = 2 + 3 + 5 = 10\Omega$

- (c) (i) What do you understand by the term nuclear fusion?
(ii) Nuclear power plants use nuclear fission reaction to produce electricity.
What is the advantage of producing electricity by fusion reaction?

Ans. (i) Nuclear fusion :

When two light nuclei are combined to form single heavy nucleus with release of energy is called nuclear fusion.

- (ii) In fusion high energy per unit mass released than fission, therefore it is useful in producing electricity.

- (d) (i) What do you understand by free vibrations of a body?
(ii) Why does the amplitude of a vibrating body continuously decrease during damped vibrations?

Ans. (i) Free vibrations are produced when a body is disturbed from its equilibrium position and released.

- (ii) Body continuously loses energy due to frictional force of the surrounding medium in damped oscillations, therefore amplitude of body continuously decreases.

- (e) (i) How is the c.m.f. across primary and secondary coils of a transformer related with the number

of turns of coil in them?

- (ii) On which type of current do transformers work?

Ans. (i)
$$\frac{E_S}{E_P} = \frac{N_S}{N_P}$$

Here e.m.f. is directly proportional to number of turns.

- (ii) Transformer works on alternating current or A.C. current.

Question 4

- (a) (i) How can a temperature in degree Celsius be converted into S.I. unit of temperature?
(ii) A liquid X has the maximum specific heat capacity and is used as a coolant in Car radiators. Name the liquid X.

Ans. (i) S.I. unit of temperature is Kelvin. To convert temperature in degree celsius to degree Kelvin 273.15 is added to celsius.

- (ii) Liquid 'X' will be 'water', as water has highest specific heat capacity.

- (b) A solid metal weighing 150 g melts at its melting point of 800°C by providing heat at the rate of 100 W. The time taken for it to completely melt at the same temperature is 4 min. What is the specific latent heat of fusion of the metal?

Ans. Given :

$$m = 150 \text{ g} = 150 \times 10^{-3} \text{ kg} = 0.15 \text{ kg}$$

$$\text{Power } (P) = 100 \text{ W, Time } (t) = 4 \text{ min} = 4 \times 60 \text{ sec}$$

The amount of heat supplied in 4 min

$$\text{Heat energy} = 100 \times 4 \times 60 = 24000 \text{ J}$$

This heat energy is used in melting.

Let ' L ' be latent specific heat.

$$\therefore M.L = 24000$$

$$\therefore L = \frac{24000}{0.15} = 16 \times 10^3 J kg^{-1}$$

(c) Identify the following wires used in a household circuit :

- (i) The wire is also called as the phase wire.
- (ii) The wire is connected to the top terminal of a three pin socket.

Ans. (i) Live wire
(ii) Earth wire

(d) (i) What are isobars ?
(ii) Give one example of isobars.

Ans. (i) The atoms of different elements which have the same mass number ' A ', but different atomic number ' Z ' are called 'Isobars'.
(ii) ${}_{11}^{23}Na$ and ${}_{12}^{23}Mg$ are isobars having same mass number '23' and different atomic numbers.

(e) State any two advantages of electromagnets over permanent magnets.

Ans. Following are the advantages of electromagnet over permanent magnets.

- (i) An electromagnet can produce a strong magnetic field.
- (ii) The strength of the magnetic field of an electromagnet can be easily changed by changing current in its solenoid.

SECTION - II (40 Marks)

Attempt any four questions from this Section

Question 5

- (a) (i) Derive a relationship between S.I. and C.G.S. unit of work.
(ii) A force acts on a body and displaces it by a distance S in a direction at an angle θ with the direction of force. What should be the value of θ to get the maximum positive work?

Ans. (i) SI unit of work = Nm (Joule)
CGS unit of work = dyne cm (erg)
 $1 N = 10^5$ dyne
 $1 m = 10^2$ cm

$$\therefore 1 \text{ Joule} = 10^5 \times 10^2 \text{ dyne cm} = 10^7 \text{ erg}$$

$$(ii) W = \vec{F} \cdot \vec{S} = FS \cos \theta$$

$$\cos \theta \text{ maximum value } 1 = FS$$

$$\therefore \theta = 0^\circ$$

- (b) A half metre rod is pivoted at the centre with two weights of 20 gf and 12 gf suspended at a perpendicular distance of 6 cm and 10 cm from the pivot respectively as shown below.

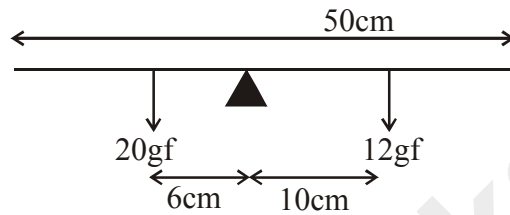

- (i) Which of the two forces acting on the rigid rod causes clockwise moment ?
(ii) Is the rod in equilibrium ?
(iii) The direction of 20 kgf force is reversed. What is the magnitude of the resultant moment of the forces on the rod?

Ans.

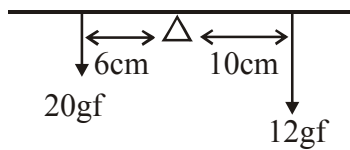

- (i) Force due to 12gf

- (ii) Yes.

- (iii) $\tau_1 = \tau_1 + \tau_2$

$$= [20 \times 10^{-3} \times 9.8 \times 6 \times 10^{-2}] + [10 \times 10^{-2} \times 9.8 \times 12 \times 10^{-3}]$$

$$= 2 \times 120 \times 10^{-3} \times 9.8 \times 10^{-2}$$

$$= 0.2352 \text{ Nm}$$

- (c) (i) Draw a diagram to show a block and tackle pulley system having a velocity ratio of 3 marking the direction of load(L), effort(E) and tension (T).
- (ii) The pulley system drawn lifts a load of 150 N when an effort of 60 N is applied. Find its mechanical advantage.
- (iii) Is the above pulley system an ideal machine or not ?

Ans. (i) Block and tackle pulley system :

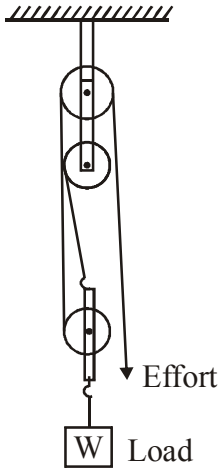

(ii) Mechanical advantage (M.A) = $\frac{\text{Load}}{\text{Effor}} = \frac{150\text{N}}{60\text{N}} = \frac{5}{2} = 2.5$

(iii) No

Question 6

- (a) A ray light XY passes through a right angled isosceles prism as shown below.

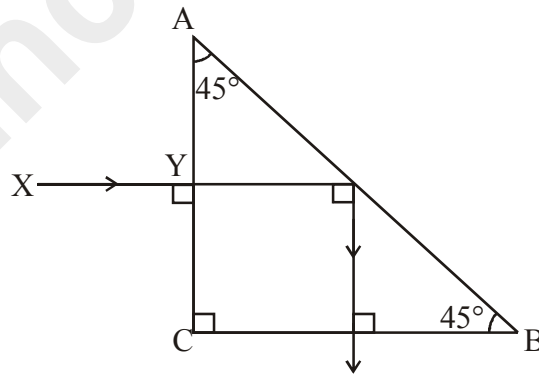

- (i) What is the angle through which the incident ray deviates and emerges out of the prism?
- (ii) Name the instrument where this action of prism is put into use.
- (iii) Which prism surface will behave as a mirror ?

Ans. (i) 90°

(ii) Periscope

(iii) AB

- (b) An object AB is placed between O and F_1 on the principal axis of converging lens as shown in the diagram.

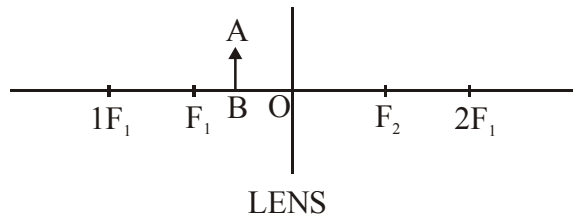

Copy the diagram and by using three standard rays starting from point A, obtain an image of the object AB.

Ans.

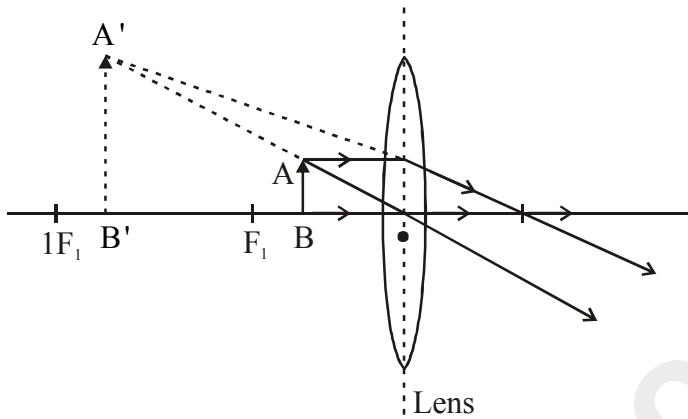

- (c) An object is placed at a distance of 12 cm from a convex lens of focal length 8 cm. Find :

- (i) the position of the image
- (ii) nature of the image

Ans.

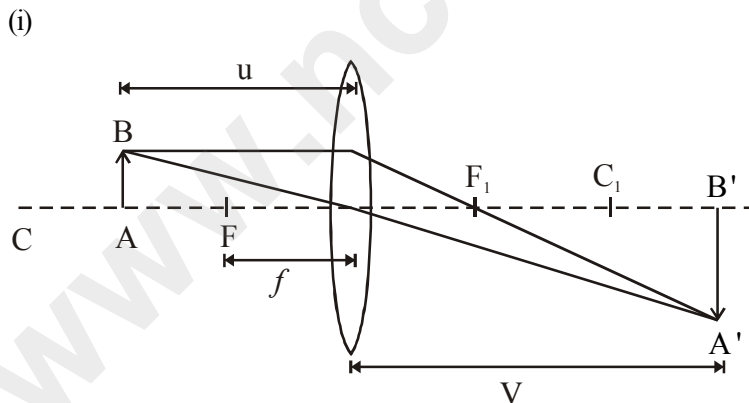

Given data :

$$u = -12 \text{ cm}, f = +8 \text{ cm}, v = ?$$

Lens formula,

$$\frac{1}{v} - \frac{1}{u} = \frac{1}{f}$$

$$\frac{1}{v} - \frac{1}{(-12)} = \frac{1}{8}$$

$$\frac{1}{v} = \frac{1}{8} - \frac{1}{12}$$

$v = 24$ cm [Position of image]

(ii) Nature of image : Real, inverted and magnified.

Question 7

(a) Draw the diagram of a right angled isosceles prism which is used to make an inverted image erect.

Ans.

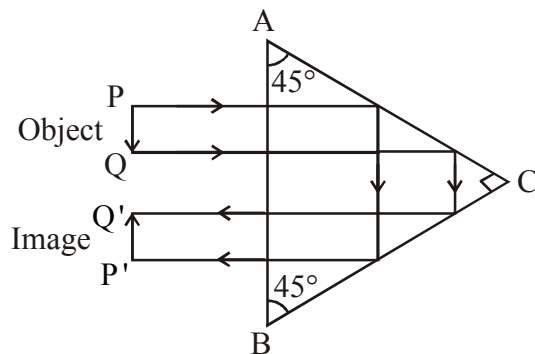

(b)

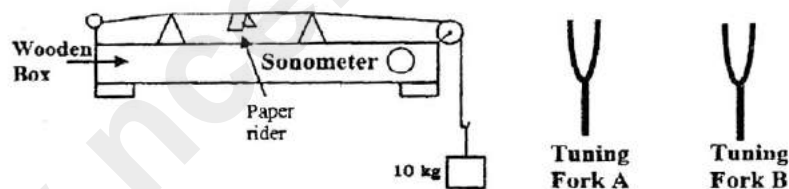

The diagram above shows a wire stretched over a sonometer. Stems of two vibrating tuning forks A and B are touched to the wooden box of the sonometer. It is observed that the paper rider (a small piece of paper folded at the centre) present on the wire flies off when the stem of vibrating tuning fork B is touched to the wooden box but the paper just vibrates when the stem of vibrating tuning fork A is touched to the wooden box.

- (i) Name the phenomenon when the paper rider just vibrates.
- (ii) Name the phenomenon when the paper rider flies off.
- (iii) Why does the paper rider fly off when the stem of tuning fork B is touched to the box?

Ans.

- (i) Vibration (The frequency of fork is close to the natural frequencies of vibrating wire).
- (ii) Resonance
- (iii) The paper rider flies off because the natural frequency of vibration of wire matches the frequency of the tuning fork.

- (c) A person is standing at the sea shore. An observer on the ship which is anchored in between a vertical cliff and the person on the shore fires a gun. The person on the shore hears two sounds, 2 seconds and 3 seconds after seeing the smoke of the fired gun. If the speed of sound in the air is 320 ms^{-1} then calculate :
- the distance between the observer on the ship and the person on the shore.
 - the distance between the cliff and the observer on the ship.

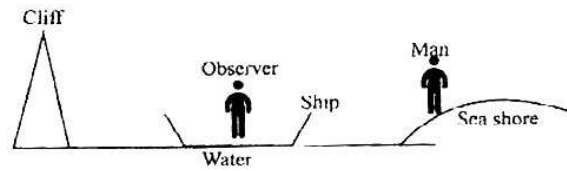

Ans. (i) $d_1 = 320 \times 1.5 = 320 \times 1.5 = 640 \text{ m}$

(ii) $d_2 = \frac{320}{2} = 160 \text{ m}$

Question 8

- (a) (i) A fuse is rated 8A. Can it be used with an electrical appliance rated 5 KW, 200 V ? Give a reason.
 (ii) Name two safety devices which are connected to the live wire of a household electric circuit.

Ans. $P = 5 \times 10^3 \text{ W}$

(i) $V = 200$

$\therefore P = IV$

$5 \times 10^3 = I[200]$

$\frac{5000}{200} = I$

$I = 25 \text{ A}$

$25 \text{ A} > 8 \text{ A}$

Yes it can be used \because current is greater than 8A

- (ii) Fuse, MCB

Switch

- (b) (i) Find the equivalent resistance between A and B.

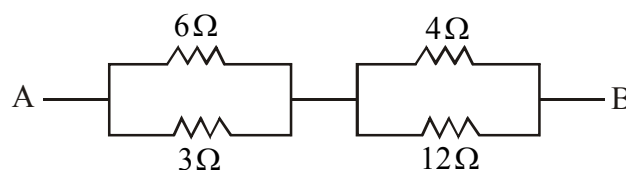

- (ii) State whether the resistivity of a wire changes with the change in the thickness of the wire.

Ans. (i) 6Ω and 3Ω are in parallel $\therefore \frac{1}{R_p} = \frac{1}{R_1} + \frac{1}{R_2}$

$$\therefore R_{p_1} = \frac{6 \cdot 3}{6 + 3} = \frac{18}{9} = 2\Omega$$

4Ω and 2Ω are in parallel $\therefore \frac{1}{R_p} = \frac{1}{R_1} + \frac{1}{R_2}$

$$\therefore R_{p_2} = \frac{4 \cdot 2}{4 + 2} = \frac{8}{6} = \frac{4}{3}\Omega$$

$$\therefore \text{Total } R_T = R_{p_1} + R_{p_2} = 2 + \frac{4}{3} = \frac{10}{3}\Omega$$

(ii) $R = \rho L / A \quad \therefore \rho = \frac{RA}{L} \quad A = \pi r^2 = \frac{R(\pi r^2)}{L}$

\Rightarrow Resistivity $\propto r^2 \Rightarrow$ Thus if thickness increases resistivity increases.

(c) An electric iron is rated 220V, 2kW.

(i) If the iron is used for 2h daily find the cost of running it for one week if it costs Rs. 4.25 per kWh.

(ii) Why is the fuse absolutely necessary in a power circuit?

Ans. (i) $P = IV$

$$2 \times 10^3 = I(220)$$

$$I = \frac{2 \times 10^3}{220} = 9.09 \text{ A}$$

$$2 \text{ kW in sec } \therefore \text{ for } 2h = 2 \text{ kW} \times 2 \times 60 \times 60 = 14400000 \text{ W} = 14400 \text{ kWh}$$

$$\text{Since cost is 4.25 per kWh therefore for 14400 kWh cost} = 14400 \times 4.25 = 61200 \text{ Rs.}$$

(ii) If excessive current passes through the type, it melts thus fuse is used to prevent excessive current passing through the device.

Question 9

- (a) (i) Heat supplied to a solid changes it into liquid. What is this change in phase called?
(ii) During the phase change does the average kinetic energy of the molecules of the substance increase?
(iii) What is the energy absorbed during the phase change called?

Ans. (i) Solid \rightarrow liquid, melting

(ii) No

(iii) Latent heat of fusion

- (b) (i) State two differences between “Heat Capacity” and “Specific Heat Capacity”.
- (ii) Give a mathematical relation between Heat Capacity and Specific Heat Capacity.

Ans. (i) Heat capacity : Amount of heat required to raise the temperature of whole body by 1°C .

- extensive
- $J/^{\circ}\text{C}$

Specific heat capacity: Amount of heat required to raise the temperature of unit mass of a pure substance by 1°C

- intensive
- $J/\text{kg}^{\circ}\text{C}$

(ii) Heat capacity = mass \times specific heat capacity

- (c) The temperature of 170g of water at 50°C is lowered to 5°C by adding certain amount of ice to it. Find the mass of ice added.

Ans. Given data :

$$M_w = 170 \text{ gm}, S_w = 1 \text{ cal} / \text{gm}^{\circ}\text{C} = 4200 \text{ J} / \text{kg}^{\circ}\text{C}$$

$$\Delta T = 5^{\circ}\text{C}, L_f = 80 \text{ cal} / \text{gm} = 336000 \text{ J} / \text{kg}$$

Amount of heat given by water = Amount of heat absorb by ice ...[Principle of calorimetry]

$$M_w S_w \Delta T = M_{ice} \times L_f$$

$$(170)(1)(5) = M_{ice} \times (80)$$

$$\therefore M_{ice} = \frac{170 \times 1 \times 5}{80} = 10.625 \text{ gm}$$

Question 10

(a)

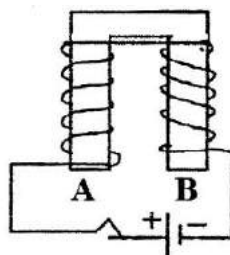

The diagram shows a coil wound around a U shape soft iron bar AB.

- (i) What is the polarity induced at the ends A and B when the switch is pressed ?
- (ii) Suggest one way to strengthen the magnetic field in the electromagnet.

(iii) What will be the polarities at A & B if the direction of current is reversed in the circuit ?

Ans. (i) A - South, B - North

(ii) Increase the number of turns of coils, increasing current.

(iii) A - North, B - South

(b) The ore of Uranium found in nature contains ${}_{92}\text{U}^{235}$ and ${}_{92}\text{U}^{238}$. Although both the isotopes are fissionable, it is found out experimentally that one of the two isotopes is more easily fissionable.

(i) Name the isotope of Uranium which is easily fissionable.

(ii) Give a reason for your answer.

(iii) Write a nuclear reaction when Uranium 238 emits an alpha particle to form a Thorium (Th) nucleus.

Ans. (i) ${}^{235}\text{U}$

(ii) ${}^{235}_{92}\text{U}$ is less stable than ${}^{238}_{92}\text{U}$

(iii) ${}^{238}_{92}\text{U} \longrightarrow {}^{234}_{90}\text{Th} + {}^4_2\text{He}$

(c) Radiations given out from a source when subjected to an electric field in a direction perpendicular to their path are shown below in the diagram. The arrows show the path of the radiation A, B and C. Answer the following questions in terms of A, B and C.

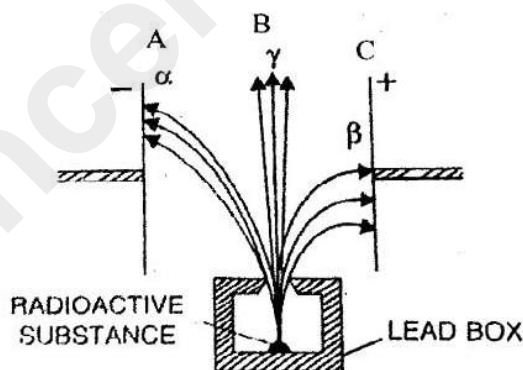

(i) Name the radiation B which is unaffected by the electrostatic field.

(ii) Why does the radiation C deflect more than A ?

(iii) Which among the three causes the least biological damage externally?

(iv) Name the radiation which is used in carbon dating.

Ans. (i) Gamma radiations

(ii) Because the mass of B particles is less than that of α , hence radiation deflects more than A.

(iii) γ rays

(iv) β radiation ${}^{14}_6\text{C} \longrightarrow {}^{14}_7\text{N} + {}^0_{-1}\beta^-$