

**ICSE Board
Class X Physics
SCIENCE Paper - I
Board Paper - 2019**

Time: 2 hours

Maximum Marks: 80

General Instructions:

Answers to this paper must be written on the paper provided separately.

*You will **not** be allowed to write during the first **15** minutes.*

This time is to be spent in reading the question paper.

The time given at the head of paper is the time allotted for writing the answers.

***Section I** is compulsory. Attend **any four** questions from **Section II**. The intended marks of questions or parts of questions are given in brackets [].*

SECTION - I (40 Marks)

*Attempt **all** question from this Section.*

Question 1

(a) The diagram below shows a claw hammer used to remove a nail; [2]

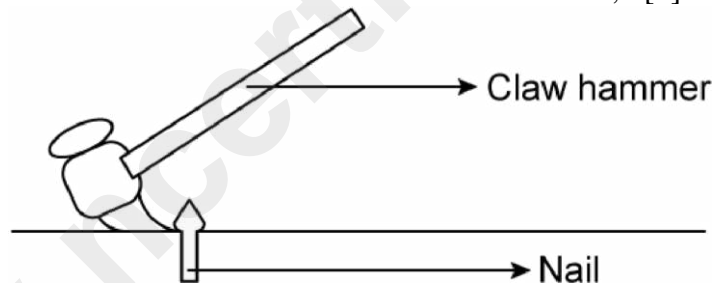

(i) To which class of lever does it belong?

(ii) Given one more example of the **same class** of lever mentioned by you in (i) for which the **mechanical advantage is greater than one**.

(b) Two bodies A and B have masses in the ratio 5:1 and their kinetic energies are in the ratio 125:9. Find the ratio of their velocities. [2]

(c) [2]

(i) Name the physical quantity which is measured in calories.

(ii) How is calories related to the S.I. unit of that quantity?

(d) [2]

(i) Define couple.

(ii) State the S.I. unit of moment of couple.

(e)

[2]

(i) Define critical angle.

(ii) State one important factor which affects the critical angle of a given medium.

Solution 1:

(a) (i) Class first lever.

(ii) Pliers.

(b) (i) Let mass, kinetic energy and velocity of bodies A and B be (m_A, m_B) , (k_A, k_B) and (v_A, v_B) respectively.

$$\text{Given: } \frac{m_A}{m_B} = \frac{5}{1}$$

$$\text{And } \frac{k_A}{k_B} = \frac{125}{9}$$

This implies,

$$\frac{\frac{1}{2} m_A (v_A)^2}{\frac{1}{2} m_B (v_B)^2} = \frac{125}{9}$$

$$\Rightarrow \frac{m_A}{m_B} \times \left(\frac{v_A}{v_B} \right)^2 = \frac{125}{9}$$

$$\Rightarrow \frac{5}{1} \times \left(\frac{v_A}{v_B} \right)^2 = \frac{125}{9}$$

$$\Rightarrow \left(\frac{v_A}{v_B} \right)^2 = \frac{125}{9} \times \frac{1}{5} = \frac{25}{9}$$

$$\Rightarrow \frac{v_A}{v_B} = \sqrt{\frac{25}{9}} = \frac{5}{3}$$

$$\therefore v_A : v_B = 5 : 3$$

(c) (i) Heat energy is measured in calories.

(ii) 1 calorie (1 cal) = 4.186 J

(d) (i) Two equal and opposite parallel forces not acting along a same line which produce rotation is called a couple. A couple is always needed to produce rotation.

(ii) The SI unit of the moment of couple is Newton-metre (Nm).

(e) (i) The angle of incidence in the denser medium corresponding to the angle of refraction in the rarer medium is 90° and is called the critical angle.

(ii) Factors affecting the critical angle: (any one)

1) Wavelength of light

2) Temperature

Question 2

(a) An electromagnetic radiation is used for photography in fog. [2]

(i) Identify the radiation.

(ii) Why is this radiation mentioned by you, ideal for this purpose?

(b) [2]

(i) What is the relation between the refractive index of water with respect to air (${}_a\mu_w$) and the refractive index of air with respect to water (${}_w\mu_a$).

(ii) If the refractive index of water with respect to air (${}_a\mu_w$) is $\frac{5}{3}$.

Calculate the refractive index of air with respect to water (${}_w\mu_a$).

(c)

The specific heat capacity of a substance A is $3,800 \text{ Jkg}^{-1}\text{K}^{-1}$ and that of a substance B is $400 \text{ Jkg}^{-1}\text{K}^{-1}$. Which of the two substances is a good conductor of heat? Give a reason for your answer. [2]

(d)

A man playing a flute is able to produce notes of different frequencies. If he closes the holders near his mouth, will the pitch of the note produced, increase or decrease? Give a reason. [2]

(e)

The diagram below shows a light source P embedded in a rectangular glass block ABCD of critical angle 42° . Complete the path of the ray PQ till it emerges out of the block. [Write necessary angles.] [2]

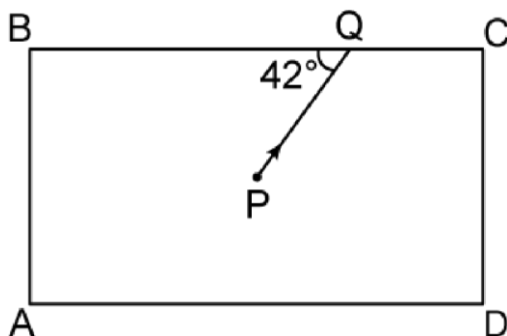

Solution 2:

- (a) (i) Infrared radiation is suitable electromagnetic radiation for photography in fog.
(ii) It is because they have low frequency, the energy associated with them is also low so they do not scatter much and can penetrate appreciably through it.

(b)

$${}_a\mu_w = \frac{\mu_w}{\mu_a}$$

$${}_w\mu_a = \frac{\mu_a}{\mu_w}$$

$$\therefore {}_a\mu_w = \frac{1}{{}_w\mu_a}$$

(ii) Given:

$${}_a\mu_w = \frac{5}{3}$$

$$\therefore {}_w\mu_a = \frac{1}{{}_a\mu_w} = \frac{3}{5}$$

(c)

Specific heat of substance A = $3800 \text{ Jkg}^{-1} \text{ K}^{-1}$

Specific heat of substance B = $400 \text{ Jkg}^{-1} \text{ K}^{-1}$

A good conductor of heat has low specific heat and a bad conductor of heat has high specific heat. Thus, substance B is a good conductor of heat.

(d) If the man closes the holes in a flute near his mouth a sound of lower frequency note will be produced because the length of vibrating air column increase and the frequency of vibrating air column is inversely proportional to the length of vibrating air column.

(e) The complete ray diagram with necessary angles is as follows:

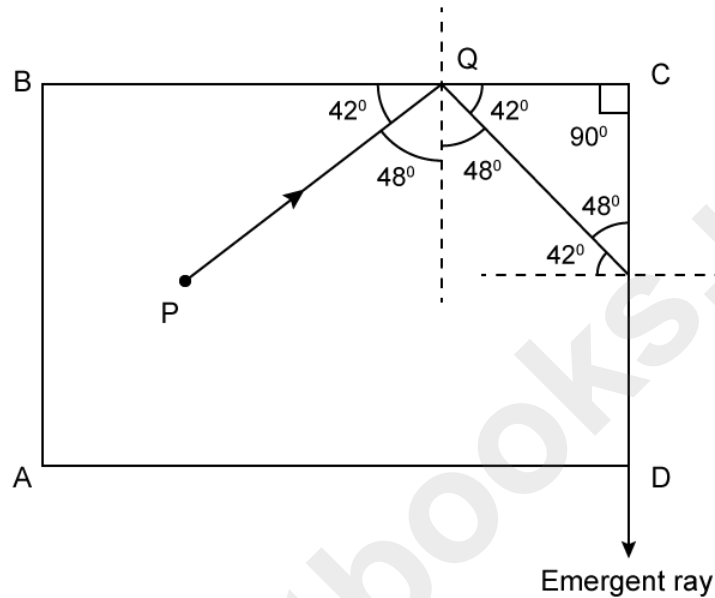

Question 3

- (a) [2]
- (i) If the lens is placed in water instead of air, how does its focal length change?
 - (ii) Which lens, thick or thin has greater focal length?
- (b) Two waves of the same pitch have amplitudes in the ratio 1: 3. [2]
 What will be the ratio of their:
- (i) Intensities and (ii) Frequencies?
- (c) How does an increase in the temperature affect the specific resistance of a: [2]
- (i) Metal and
 - (ii) Semiconductor?
- (d) [2]
- (i) Define resonant vibrations.
 - (ii) Which characteristic of sound, makes it possible to recognize a person by his voice without seeing him?
- (e) It is possible for a hydrogen (H) nucleus to emit an alpha particle? [2]

Solution 3:

- (a) (i) Focal length does not depend in external parameter.
(ii) A thin lens has a greater focal length than a thick length.

(b) (i) Same pitch: $\frac{A_1}{A_2} = \frac{1}{3}$

Intensities, $I \propto A^2$

$$\therefore \frac{I_1}{I_2} = \frac{1}{9}$$

- (ii) Frequency of sound is independent of amplitude.

Thus, $f_1:f_2 = 1:1$

- (c) (i) For metals, with increase in temperature, the specific resistance increases.

- (ii) Specific resistance of a semiconductor decreases with the increases in temperature.

- (d) (i) When the frequency of the externally applied periodic force on the body is equal to its natural frequency, the body begins to vibrate with an increased amplitude. Such large amplitude vibrations are called resonant vibrations.

- (ii) Quality of sound or Timbre.

- (e) No, it is not possible because an alpha particles consists of two protons and two neutrons.

Question 4

- (a) Calculate the effective resistance across AB: [2]

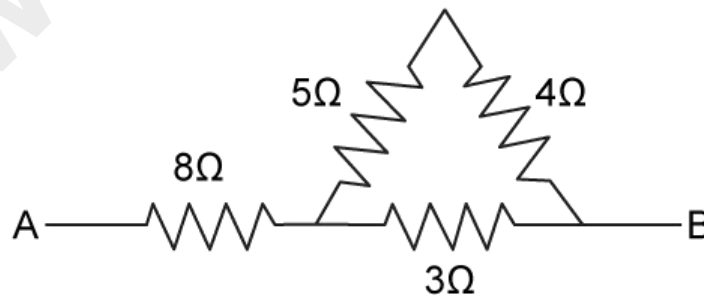

- (b) [2]
(i) State whether the specific heat capacity of a substance remains the same when its state changes from solid to liquid.
(ii) Given one example to support your answer.

(c) A magnet kept at the centre of two coils A and B is moved to and fro as shown in the diagram. The two galvanometers show deflection. [2]

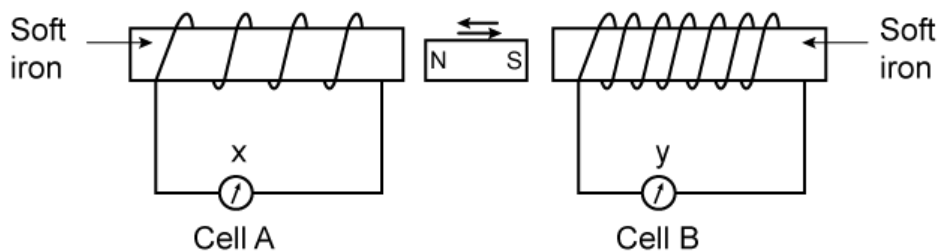

State with a **reason** whether:

$$x > y$$

$$\text{or } x < y.$$

[x and y are magnitudes of deflection.]

(d)

[2]

(i) Why a nuclear fusion reaction is called a thermos nuclear reaction?

(ii) Complete the reaction:



(e) State two ways to increase the speed of rotation of a D.C. motor. [2]

Solution 4:

(a) It is given that 5Ω and 4Ω in series.

$$\therefore R_1 = (5 + 4)\Omega = 9\Omega$$

Diagram can be simplified as follows:

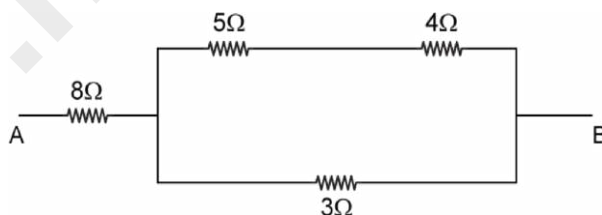

Now, 9Ω and 3Ω are in parallel.

$$\therefore R_2 = \frac{9 \times 3}{9 + 3} = \frac{27}{12} = \frac{9}{4}\Omega$$

Now, 8Ω and R_2 are in series

$$\therefore R_3 = 8 + \frac{9}{4} = \frac{41}{4}\Omega = 10.25\Omega$$

(b) (i) The specific heat capacity of a substance is different in its different phases.

(ii) The specific heat capacity of water is $4200 \text{ JK}^{-1}\text{kg}^{-1}$.

In the solid state (ice): $2100 \text{ JK}^{-1}\text{kg}^{-1}$

In the vapour state (steam): $460 \text{ JK}^{-1}\text{kg}^{-1}$

(c) $x < y$, because the number of turns of coil is maximum in coil B rather than in coil A.

(d) (i) Nuclear fusion is not possible at normal temperature. At high temperature and due to thermal agitations, both nuclei acquire sufficient kinetic energy to overcome the force of repulsion between them when they approach each other and thus get fused.

Thus, the nuclear fusion reaction is also called a thermonuclear reaction.

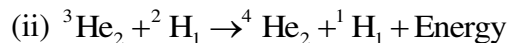

(e) Ways to increase the speed of rotation of a DC motor:

1. By increasing the strength of current in the coil
2. By increasing the number of turns in the coil

SECTION II (40 Marks)

Attempt any **four** questions from this Section

Question 5

(a) A body of mass 10 Kg is kept at a height of 5 m. It is allowed to fall and reach the ground.

[3]

- (i) What is the total mechanical energy possessed by the body at the height of 2 m assuming it is a frictionless medium?
- (ii) What is the kinetic energy possessed by the body just before hitting the ground? Take $g = 10\text{m/s}^2$.

(b) A uniform meter scale is in equilibrium as shown in the diagram: [3]

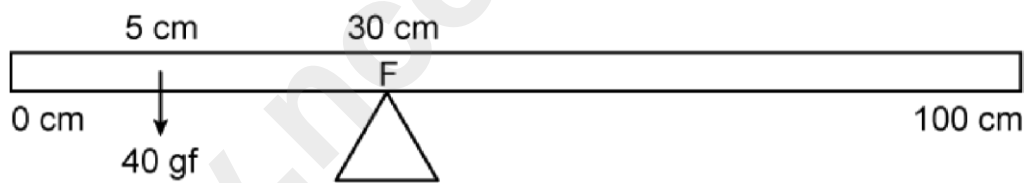

- (i) Calculate the weight of the meter scale.
- (ii) Which of the following options is correct to keep the ruler in equilibrium when 40 gf wt is shifted to 0 cm mark?
F is shifted towards 0 cm. or
F is shifted towards 100 cm.

(c) The diagram below shown a pulley arrangement: [4]

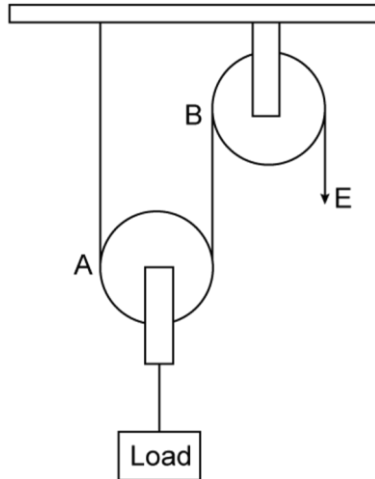

- (i) Copy the diagram and mark the direction of tension on each strand of the string.
- (ii) What is the velocity ratio of the arrangement?
- (iii) If the tension acting on the string is T , then what is the relationship between T and effort E ?
- (iv) If the free end of the string moves through a distance x , find the distance by which the load is raised.

Solution 5:

(a) It is given that Mass(m) = 10 kg,

Height(h) = 5m,

$g = 10\text{ms}^{-2}$,

Potential Energy (U) = mgh

$$= 10 \times 10 \times 5\text{J}$$

$$= 500\text{J}$$

(ii) According to the law of conservation of energy, the kinetic energy possessed by the body just before touching the ground is 500J.

(b) (i) Let the weight of the meter scale be x gf and it acts at the centre of gravity (ie, 50 cm mark).

Anti- clock wise moment = 40×25 gf cm

Clockwise moment = $x \times 20$ gf cm

When the meter scale is balanced,

Clockwise moment = Anticlockwise moment

$$\Rightarrow x \times 20 = 40 \times 25$$

$$\Rightarrow x = \frac{40 \times 25}{20} \text{ gf}$$

$$= 50\text{gf}$$

Therefore, Weight of meter scale is 50gf.

(ii) F is shifted towards 0 cm.

(c) (i) The diagram with direction of tension on each strand is shown below:

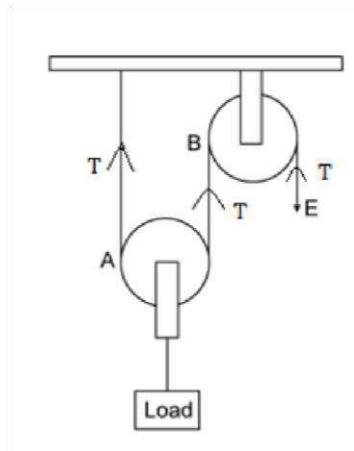

(ii) Velocity ratio = 2

(iii) $E = T$

(iv) The load will be raised by a distance $\frac{x}{2}$.

Question 6

(a) How does the angle of deviation formed by a prism change with the increase in the angle of incidence? [3]

Draw a graph showing the variation in the angle of deviation with the angle of incidence at a prism surface.

(b) A virtual, diminished image is formed when an object is placed between the optical centre and the principal focus of a lens. [3]

(i) Name the type of lens which forms the above image.

(ii) Draw a ray diagram to show the formation of the image with the above stated characteristics.

(c) An object is placed at a distance of 24 cm from a convex lens of focal length 8 cm. [4]

(i) What is the nature of the image so formed?

(ii) Calculate the distance of the image from the lens.

(iii) Calculate the magnification of the image.

Solution 6:

(a) (i) As the angle of incidence increases, the angle of deviation first decreases, reaches to a maximum value for a critical angle of incidence, and then on further increasing the angle of incidence, the angle of deviation begins to increase.

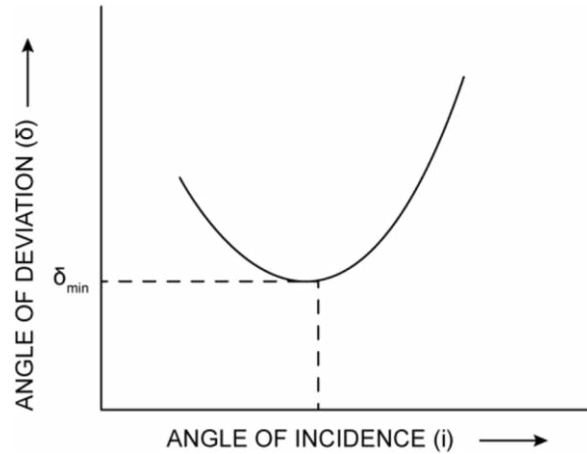

(b) (i) Concave Lens.

(ii) Ray diagram to show the formation of image (A'B') is give below:

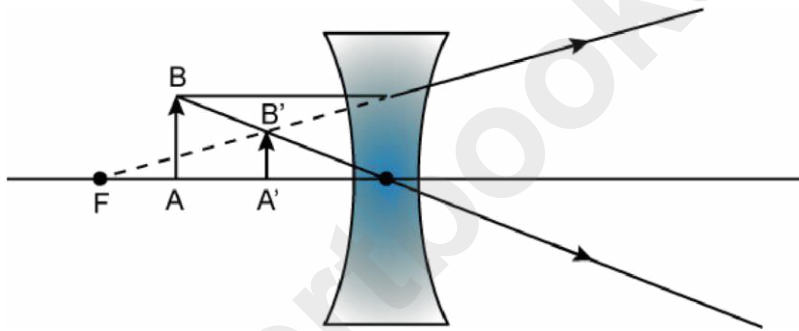

(c) (i) A real inverted and diminished image is formed.

(ii) It is given that:

$$u = -24\text{cm}, f = +8\text{cm}$$

From the relation,

$$\begin{aligned} \frac{1}{u} - \frac{1}{v} &= \frac{1}{f} \\ \Rightarrow \frac{1}{v} &= \frac{1}{u} + \frac{1}{f} \\ &= \frac{1}{-24} + \frac{1}{8} \\ &= \frac{-1+3}{24} = \frac{1}{12} \end{aligned}$$

$$\text{Or } v = 12 \text{ cm}$$

Therefore, the image is at a distance 12cm behind the lens.

$$\text{(iii) Magnification (m), } \frac{v}{u} = \frac{12}{-24} = -\frac{1}{2}$$

Negative sign signifies inverted image.

Question 7

- (a) It is observed that during march-past we hear a base drum distinctly from a distance compared to the side drums. [3]
- Name the characteristic of sound associated with the above observation.
 - Given a reason for the above observation.
- (b) A pendulum has a frequency of 4 vibrations per second. An observer starts the pendulum and fires a gun simultaneously. He hears the echo from the cliff after 6 vibrations of the pendulum. If the velocity of sound in air is 340 m/s, find the distance between the cliff and observer. [3]
- (c) Two pendulums C and D are suspended from a wire as shown in the figure given below. Pendulum C is made to oscillate by displacing it from its mean position. It is seen that D also starts oscillating. [4]

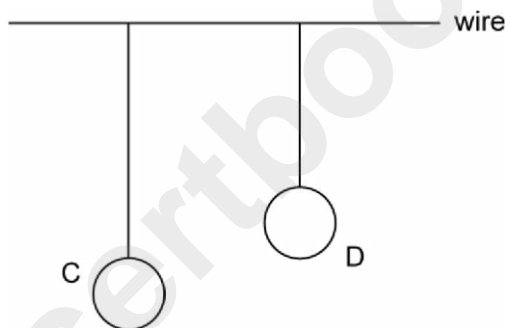

- Name the type of oscillation, C will execute.
- Name the type of oscillation, D will execute.
- If the length of D is made equal to C then what difference will you notice in the oscillations of D?
- What is the name of the phenomenon when the length of D is made equal to C?

Solution 7:

(a) (i) Pitch and Timbre.

(ii) The amplitude of vibration of medium particles is very large in the base drum compared to the side drum. The frequency of vibration of medium particles is also very low compared to the side drum.

(b) Time taken to complete 4 vibration = 1 second

Time taken to complete 1 vibration = $\frac{1}{4}$ second

Thus, Time taken to complete 6 vibrations

$$= \frac{1}{4} \times 6 \text{ seconds}$$

$$= 1.5 \text{ seconds}$$

Time = 1.5s

Velocity = 340m/s

Thus, Distance between the cliff and observer

$$d = \frac{v \times t}{2}$$

$$= \frac{340 \times 1.5}{2} \text{ m}$$

$$= 255 \text{ m}$$

(c) (i) C will execute free or natural oscillations.

(ii) D will execute forced oscillations.

(iii) The natural frequency of D becomes equal to C, and therefore, there is exchange of energy between C and D. Pendulum D starts oscillating slowly with small amplitude, and it ultimately acquires the same amplitude which pendulum C initially had.

(iv) Resonance.

Question 8

(a) [3]

- (i) Write one advantage of connecting electrical appliance in parallel combination.
- (ii) What characteristic should a fuse wire have?
- (iii) Which wire in a power circuit is connected to the metallic body of the appliance?

(b) The diagram below shows a dual control switch circuit connected to a bulb. [3]

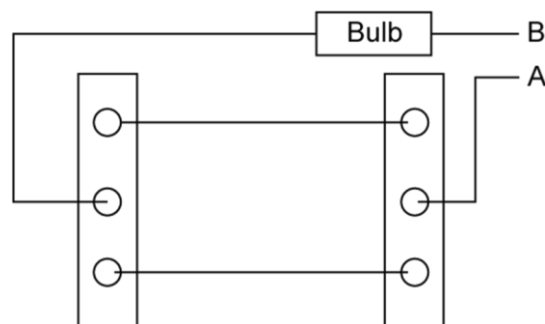

- (i) Copy the diagram and complete it so that bulb is switch ON.
- (ii) Out of A & B which one is the live wire and which one is the neutral wire?

(c)

[4]

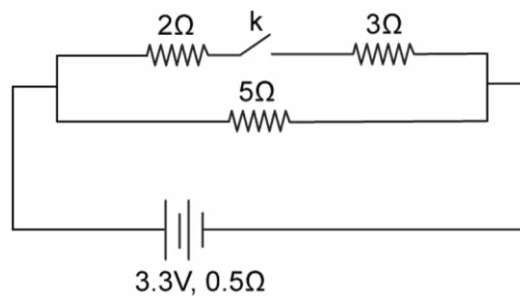

The diagram above shows a circuit with the key k open. Calculate:

- (i) the resistance of the circuit when the key k is open.
- (ii) the current drawn from the cell when the key k is open.
- (iii) the resistance of the circuit when the key k is closed.
- (iv) the current drawn from the cell when the key k is closed.

Solution 8:

- (a) (i) Each appliance gets connected to 220 V supply for its normal working.
- (ii) Fuse wire must have low melting point and its specific resistance must be more than that of copper or aluminium.
- (iii) Earth wire.

(b) (i) The diagram below shows the bulb in switched ON mode:

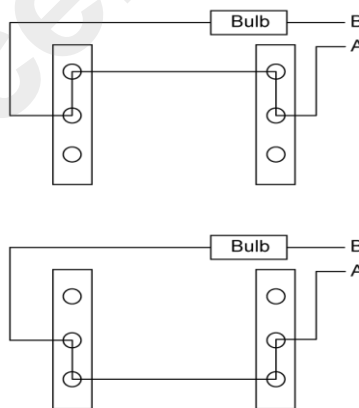

(ii) A is live wire, B is neutral wire.

(c) When the key k is open:

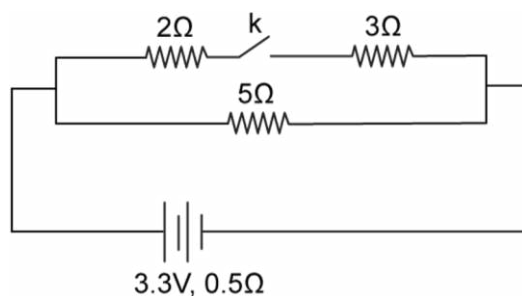

Resistance (R_1) of the circuit $= (5 + 0.5)\Omega = 5.5\Omega$

(ii) When key is closed:

2Ω and 3Ω are in series and their equivalent resistance $= (2 + 3)\Omega = 5\Omega$

5Ω and 5Ω are in parallel

$$\frac{1}{R_p} = \frac{1}{5} + \frac{1}{5} = \frac{1+1}{5} = \frac{2}{5}$$

$$R_p = \frac{5}{2}\Omega = 2.5\Omega$$

Resistance of circuits (R_2) when key k is closed

$$= (R_p + 0.5)\Omega$$

$$= (2.5 + 2.5)\Omega$$

$$= 3.0\Omega$$

(iv) Current (I_2) drawn when key k is closed

$$= \frac{V}{R_2} = \frac{3.3}{3} \text{ A} = 1.1 \text{ A}$$

Question 9

(a)

[3]

(i) Define Calorimetry.

(ii) Name the material used for making a Calorimeter.

(iii) Why is a Calorimeter made up of thin sheets of the above material answered in (ii)?

(b)

The melting point of naphthalene is 80°C and the room temperature is 30°C . A sample of liquid naphthalene at 100°C is cooled down to the room temperature.

Draw a temperature time graph to represent this cooling. In the graph, mark the region which corresponds to the freezing process. [3]

(c)

104 g of water at 30°C is taken in a calorimeter made of copper of mass 42g. When a certain mass of ice at 0°C is added to it, the final temperature of the mixture after the ice has melted, was found to be 10°C . Find the mass of ice added.

[Specific heat capacity of water $= 4.2 \text{ J g}^{-1} \text{ }^\circ\text{C}^{-1}$; Specific latent heat of fusion of

ice = 336Jg⁻¹; Specific heat capacity of copper = 0.4 J g⁻¹ °C⁻¹] [4]

Solution 9:

- (a) (i) The measurement of the quantity of heat is called calorimetry.
- (ii) Copper.
- (iii) Calorimeter made up of thin sheets of copper because copper is a good conductor of heat, the vessel acquires the temperature of its contents quickly. Copper also has low specific heat; therefore, a small amount of energy is needed to acquire that temperature.

(b) (i) BC represents the freezing process in the below graph:

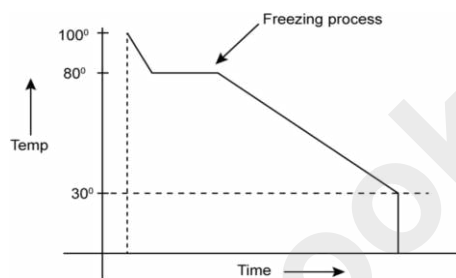

(c) It is given that

$$m_w = 104\text{g},$$

$$T_w = 30^\circ\text{C}$$

$$m_c = 42\text{ g},$$

$$T = 10^\circ\text{C}$$

$$m_i = ?$$

Bt calorimeter,

Heat lost = Heat gained

$$m_w S_w (t_w - T) + m_c S_c (T_w - T) = m_i \alpha + m_i S_w (T - T_i)$$

$$\Rightarrow (104)(4.2)(30 - 10) + (42)(0.4)(30 - 10) = m_i (336) + m_i (4.2)(10 - 0)$$

$$\Rightarrow m_i = \frac{(104)(4.2)(20) + (42)(0.4)(20)}{(336 + 42)}$$

$$\Rightarrow m_i = 24\text{g}$$

Question 10

(a) Draw a neat labeled diagram of an A.C. generator. [3]

(b) [3]

- (i) Define nuclear fission.
- (ii) Rewrite and complete the following nuclear reaction by filling in the atomic number of Ba and mass number of Kr:

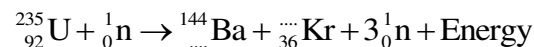

(c)

The diagram below shows a magnetic needle kept just below the conductor AB which is kept in North South direction. [4]

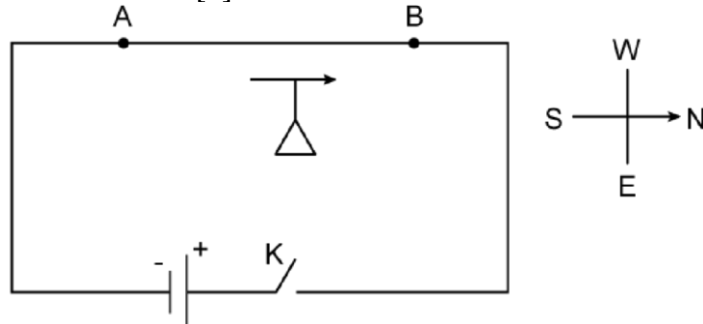

- (i) In which direction will the needle deflect when the key is closed?
- (ii) Why is the deflection produced?
- (iii) What will be the change in the deflection if the magnetic needle is taken just above the conductor AB?
- (iv) Name one device which work on this principle.

Solution 10:

(a) The diagram of A.C. generator is shown below:

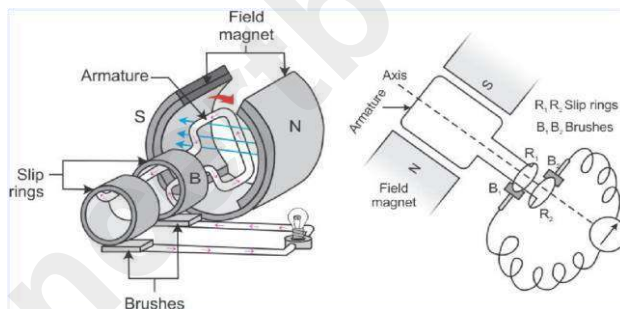

(b) (i) Nuclear fission is the process in which a heavy nucleus is split into two light nuclei of nearly the same size, by bombarding it with slow neutrons.

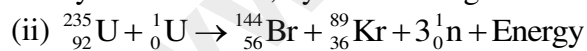

- (c) (i) Needle deflects towards the east.
- (ii) On passing the current in the wire AB, a magnetic field is produced around it and the magnetic needle experiences a torque in this magnetic field, so it deflects to align itself in the direction of the magnetic field at that point.
- (iii) Needle deflects towards the West.
- (iv) Electric motor