

Attempt **all** questions from **Section A** and **any four** questions from **Section B**.  
**All working, including rough work, must be clearly shown and must be done on the same sheet as the rest of the answer.**

**Omission of essential working will result in loss of marks.**

The intended marks for questions or parts of questions are given in brackets [ ].

**Mathematical tables are provided.**

---

### SECTION A (40 Marks)

Attempt **all** questions from this Section.

#### Question 1

(a) Solve the following in equation and write down the solution set: [3]

$$5x - 12 < 10x + 3 \leq 7x + 15, x \in W$$

**Represent the solution on a real number line.**

**Ans.** The given inequality is:

$$5x - 12 < 10x + 3 \leq 7x + 15$$

which forms two cases that are:

$$\text{Case 1: } 10x + 3 > 5x - 12$$

$$\text{Case 2: } 10x + 3 \leq 7x + 15$$

Solving the case 1, we have

$$10x + 3 > 5x - 12$$

$$\Rightarrow 10x - 5x > -12 - 3$$

$$\Rightarrow 5x > -15$$

$$\Rightarrow x > \frac{-15}{5}$$

$$\therefore x > -3$$

Solving the case 2, we get

$$10x + 3 \leq 8x + 15$$

$$\Rightarrow 10x - 7x \leq 15 - 3$$

$$\Rightarrow 3x \leq 12$$

$$\Rightarrow x \leq \frac{12}{3}$$

$$\therefore x \leq 4$$

So, we get  $x > -3$  and  $x \leq 4$

$$\Rightarrow -3 < x \leq 4$$

Since  $x \in \mathbb{w}$ , Therefore,  $x = \{0, 1, 2, 3, 4\}$

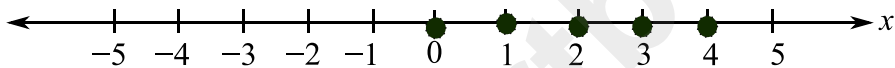

**(b) A man invests Rs. 5100 in shares of a company which is paying 10% dividend. If Rs. 100 shares are available at a discount of 15%. Find: [3]**

**(i) Number of shares he purchases.**

**(ii) His annual income.**

**Ans.** Given,

Total amount of investment = Rs. 5100

Dividend (%) = 10%

Face value = Rs. 100

Discount offered (%) = 15%

Market Value of share = 100 - 15% of 100

$$= 100 - 15$$

$$= \text{Rs.}85$$

We know that, Numbers of share =  $\frac{\text{Investment}}{\text{Market value}}$

$$= \frac{5100}{85} = 60 \text{ shares}$$

Also, Annual Income =  $\frac{\text{Number of share} \times \text{Dividend percent} \times \text{Face value}}{100}$

$$= \frac{60 \times 10 \times 100}{100}$$

$$= \text{Rs. } 600$$

Hence, the total number of shares purchased is 60 and the annual income is Rs. 600

**(c) In class of 60 students, marks obtained by the students a class test (out of 10) are given below,**

Marks	1	2	3	4	5	6	7	8	9	10
Number of students	2	5	6	6	5	15	6	5	8	2

**Calculate the following for the given distribution: [4]**

**(i) Median**

**(ii) Mode**

**Ans.** Let the marks obtained be represented by  $x$  and the number of students be represented by  $f$

Then, we can arrange the data as:

Marks( $x$ )	Number of students( $f$ )	( $fx$ )
1	2	2
2	5	10
3	6	18
4	6	24
5	5	25
6	15	90
7	6	42
8	5	40
9	8	72
10	2	20
Total	$\sum f = 60$	$\sum fx = 343$

i. We know, Mean =  $\frac{\sum fx}{\sum f}$

$$= \frac{343}{60} = 5.72$$

ii. Mode = Class with highest frequency

Here in the above table, we see 15 is the highest frequency

Hence, Mode =6

### Question 2

**(a) Using the factor theorem, show that  $(x - 3)$  is a factor of  $x^3 + x^2 - 9x - 9$ , Hence, factorise the polynomial completely. [3]**

**Ans.** Let's take the given polynomial be P(x).

We have  $P(x) = x^3 + x^2 - 9x - 9$

According to question,  $(x - 3)$  is a factor of given polynomial

We know that, under factor theorem,  $x-a$  is a factor of  $P(x)$  only if  $P(a) = 0$

So, to prove that, we substitute the value of  $x$  by 3

$$P(3) = 3^3 + 3^2 - 9 \times 3 - 9$$

$$P(3) = 27 + 9 - 27 - 9$$

$$P(3) = 0$$

Therefore,  $x-3$  is a factor of  $P(x)$

Now, factorising the polynomial, we get

$$x^3 + x^2 - 9x - 9$$

$$= x^3 - 9x + x^2 - 9$$

$$= x(x^2 - 9) + 1(x^2 - 9) \quad [ \because (a^2 - b^2) = (a+b)(a-b) ]$$

$$= (x^2 - 9)(x + 1)$$

$$= (x + 3)(x - 3)(x + 1)$$

**(b) Prove that:** 
$$\frac{\cot^2 \theta (\sec \theta - 1)}{(1 + \sin \theta)} + \frac{\sec^2 \theta (\sin \theta - 1)}{(1 + \sec \theta)} = 0 \quad [3]$$

Ans. Given, L.H.S =

$$\frac{\cot^2 \theta (\sec \theta - 1)}{(1 + \sin \theta)} + \frac{\sec^2 \theta (\sin \theta - 1)}{(1 + \sec \theta)}$$

$$= \frac{\cot^2 \theta (\sec \theta - 1)(1 + \sec \theta) + \sec^2 \theta (\sin \theta - 1)(1 + \sin \theta)}{(1 + \sec \theta)(1 + \sin \theta)}$$

$$= \frac{\cot^2 \theta (\sec^2 \theta - 1) + \sec^2 \theta (\sin^2 \theta - 1)}{(1 + \sec \theta)(1 + \sin \theta)}$$

$$= \frac{c \cot^2 \theta \tan^2 \theta + \sec^2 \theta (-\cos^2 \theta)}{(1 + \sec \theta)(1 + \sin \theta)}$$

$$= \frac{c \cot^2 \theta \tan^2 \theta - \sec^2 \theta \cos^2 \theta}{(1 + \sec \theta)(1 + \sin \theta)}$$

$$= \frac{c \cot^2 \theta \times \frac{1}{c \cot^2 \theta} - \sec^2 \theta \times \frac{1}{\sec^2 \theta}}{(1 + \sec \theta)(1 + \sin \theta)}$$

$$= \frac{1 - 1}{(1 + \sec \theta)(1 + \sin \theta)}$$

$$= 0$$

= R.H.S.

Hence, L.H.S = R.H. S proved.

**(c) In an Arithmetic Progression (A.P.) the second and seventh terms are 3 and 13 respectively, Find the:[4]**

**(i) First term**

**(ii) Common difference**

**(iii) Sum of the first 10 terms**

**Ans.**

Let the first term of A.P be 'a' and common difference be 'd'.

Then using formula  $a_n = a + (n-1)d$  to get  $n^{th}$  term, we get

$$a_2 = a + (2-1)d$$

$$\Rightarrow 3 = a + d \dots \dots \dots (i)$$

[Given: Second term is 3 and seventh term is 13]

Also,

$$a_7 = a + (7-1)d$$

$$\Rightarrow 13 = a + 6d \dots \dots \dots (ii)$$

Now, solving (i) and (ii) simultaneously, we get

$$a + d - a - 6d = 3 - 13$$

$$\Rightarrow -5d = -10$$

$$\therefore d = 2$$

Putting value of d in (i), we get

$$a + 2 = 3$$

$$\therefore a = 1$$

We know that, the sum of first n terms =  $\frac{n}{2}[2a+(n-1)d]$

So, the sum of first 10 terms

$$\begin{aligned} S_{10} &= \frac{10}{2}[2(1)+(10-1)2] \\ &= 5(2+9 \times 2) \\ &= 5(2+18) \\ &= 5 \times 20 \\ &= 100 \end{aligned}$$

### Question 3

(a) Simplify: [3]

$$\cos A \begin{bmatrix} -\sin A & \cos A \\ \cos A & \sin A \end{bmatrix} + \sin A \begin{bmatrix} \cos A & \sin A \\ \sin A & -\cos A \end{bmatrix}$$

Ans.

$$\begin{aligned} &\cos A \begin{bmatrix} -\sin A & \cos A \\ \cos A & \sin A \end{bmatrix} + \sin A \begin{bmatrix} \cos A & \sin A \\ \sin A & -\cos A \end{bmatrix} \\ &= \begin{bmatrix} -\sin A \cdot \cos A & \cos^2 A \\ \cos^2 A & \cos A \cdot \sin A \end{bmatrix} + \begin{bmatrix} \sin A \cdot \cos A & \sin^2 A \\ \sin^2 A & -\cos A \cdot \sin A \end{bmatrix} \\ &= \begin{bmatrix} -\sin A \cdot \cos A + \sin A \cdot \cos A & \cos^2 A + \sin^2 A \\ \cos^2 A + \sin^2 A & \cos A \cdot \sin A + (-\cos A \cdot \sin A) \end{bmatrix} \\ &= \begin{bmatrix} -\sin A \cdot \cos A + \sin A \cdot \cos A & 1 \\ 1 & \cos A \cdot \sin A - \cos A \cdot \sin A \end{bmatrix} \left[ \because \sin^2 A + \cos^2 A = 1 \right] \\ &= \begin{bmatrix} 0 & 1 \\ 1 & 0 \end{bmatrix} \end{aligned}$$

(b) P and Q are two points on the X axis and Y axis respectively. A(6, 5) divides the line segment PQ in the ratio 5 : 6. Find: [3]

(i) The coordinates of P and Q

(ii) Slope of the line PQ.

**Ans.**

Let the co ordinates of P and Q be (a,0) and (0,b) on x-axis and y- axis respectively

We know that,

The co ordinates of the point which divides the line segment joining  $(x_1, y_1)$  and  $(x_2, y_2)$

internally in the ratio m:n is  $\left( \frac{mx_2 + nx_1}{m+n}, \frac{my_2 + ny_1}{m+n} \right)$

According to question, A(6,5) divides the line joining P and Q internally in the ratio 5:6,

Thus, using the above formula, we get

$$\left( \frac{6a}{11}, \frac{5b}{11} \right) = (6, 5)$$

So,

$$\frac{6a}{11} = 6$$

$$\Rightarrow a = \frac{6 \times 11}{6}$$

$$\therefore a = 11$$

And

$$\frac{5b}{11} = 5$$

$$\Rightarrow b = \frac{5 \times 11}{5}$$

$$\therefore b = 11$$

Therefore, the required coordinates of P and Q are (11, 0) and (0, 11)

Now,

P(11,0) and Q(0,11)

We know, slope of the line =  $\frac{y_2 - y_1}{x_2 - x_1}$

Therefore, Slope of line PQ =  $\frac{11-0}{0-11} = \frac{11}{-11} = -1$

**(c) A solid metallic sphere of radius 9 cm is melted and made into a solid cylinder of height 54cm. Find the: [4]**

**(i) Radius of the cylinder**

**(ii) Curved surface area of the cylinder**

**Take  $\pi = 3.1$**

**Ans.**

(i) Given, radius of metallic sphere( $r$ ) = 9cm

We know, volume of sphere =  $\frac{4}{3}\pi r^3$

$\therefore$  Volume of metallic sphere =  $\frac{4}{3}\pi(7)^3$

Let  $r_1$  be radius of the cylinder

Height of the cylinder ( $h$ ) = 54cm

We know, volume of cylinder =  $\pi r^2 h$

$\therefore$  Volume of given cylinder =  $\pi r_1^2 \times 54$

Now, according to question,

Volume of sphere = Volume of cylinder

$$\Rightarrow \frac{4}{3}\pi(9)^3 = \pi r_1^2 \times 54$$

$$\Rightarrow \frac{4}{3} \times 729 = 54r_1^2$$

$$\Rightarrow \frac{4 \times 729}{3 \times 54} = r_1^2$$

$$\Rightarrow r_1^2 = 18$$

$$\therefore r_1 = 9$$

Hence, the radius of the cylinder is 9cm

(ii.) Height of cylinder (h) = 54 cm and radius(r) = 9cm

So, The curved surface area of cylinder =  $2\pi rh$

$$= 2 \times 3.1 \times 9 \times 54$$

$$= 3013.2$$

#### Question 4

(a) The following numbers,  $x + 2$ ,  $2x - 4$ ,  $3x - 12$  and  $x+3$  are in proportion. Find K. [3]

**Ans.** Given that,  $x + 2$ ,  $2x - 4$ ,  $3x - 12$  and  $x+3$  are in proportion.

$$\therefore \frac{x+2}{2x-4} = \frac{3x-12}{x+3}$$

$$\Rightarrow (x+2)(x+3) = (3x-12)(2x-4)$$

$$\Rightarrow x^2 + 3x + 2x + 6 = 6x^2 - 12x - 24x + 48$$

$$\Rightarrow x^2 + 5x + 6 = 6x^2 - 36x + 48$$

$$\Rightarrow x^2 + 5x + 6 - 6x^2 + 36x - 48 = 0$$

$$\Rightarrow -5x^2 + 41x - 42 = 0$$

$$\Rightarrow 5x^2 - 41x + 42 = 0$$

$$\Rightarrow 5x^2 - 35x - 6x + 42 = 0$$

$$\Rightarrow 5x(x-7) - 6(x-7) = 0$$

$$\Rightarrow (x-7)(5x-6) = 0$$

either,

$$(x-7) = 0$$

$$x = 7$$

Or

$$(5x-6) = 0$$

$$x = \frac{6}{5}$$

$$\therefore x = 7 \text{ or } \frac{6}{5}$$

**(b) Solve for x the quadratic equation  $x^2 + 5x - 6 = 0$ . Give your answer correct to three significant figures. [3]**

**Ans.**

Given equation,  $x^2 + 5x - 6 = 0$

Comparing it with the quadratic equation  $ax^2 + bx + c = 0$ , we get

$a = 1$ ,  $b = 5$  and  $c = -6$

$$\therefore b^2 - 4ac = (5)^2 - 4 \times 1 \times (-6)$$

$$= 25 + 24$$

$$= 49$$

Substituting this value in the formula  $x = \frac{-b \pm \sqrt{b^2 - 4ac}}{2a}$

We get,

$$x = \frac{-(5) \pm \sqrt{49}}{2 \times 1}$$
$$\Rightarrow x = \frac{-5 \pm 7}{2}$$
$$\Rightarrow x = \frac{-5 + 7}{2} = 1$$
$$\Rightarrow x = \frac{-5 - 7}{2} = -6$$

$\therefore x = 1 \text{ or } -6$

**(c) Use ruler and compass only for answering this question. Draw a circle of radius 4 cm. Mark the centre as O. Mark a point P outside the circle at a distance of 7 cm from the centre, Construct two tangents to the circle from the external point P. Measure and write down the length of any one tangent.**

**Ans.** Steps for construction are as below:

- i. Take measure 4 cm in compass and draw a circle, with center as O.
- ii. Draw a straight line from O to P, such that  $OP = 7\text{cm}$
- iii. Now find the midpoint of OP by drawing a perpendicular bisector
- iv. Mark the midpoint as X
- v. Take measure of XO in the compass and cut arcs at S and T on the Circle
- vi. Join PS and PT
- vii. Measure of PS comes out to be 5.74 cm

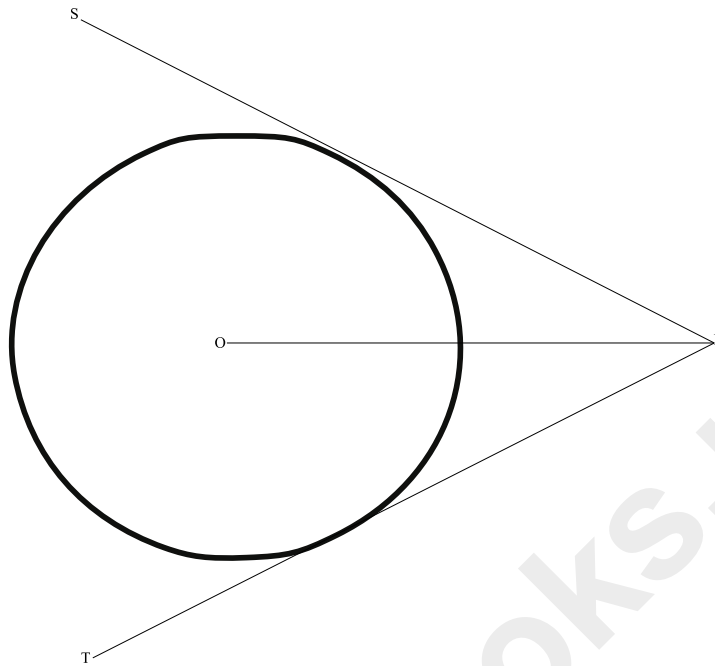

**SECTION B (40 Marks)**

Attempt any **four** questions from this Section.

**Question 5**

(a) There are 30 discs numbered 1 to 30. They are put in a closed box and shaken thoroughly. A disc is drawn at random from the box. [3]

Find the probability that the number on the disc is:

- (i) An even number
- (ii) Divisible by 2 and 3 both.
- (iii) A number less than 18.

**Ans.**

According to question,

Total number of discs numbered 1 to 30 = 30

So, the number of possible outcomes in the sample space is  $n(S) = 30$

We know, Probability of an event =  $\frac{\text{Number of favourable outcomes}}{\text{Total number of possible outcomes}}$

i. Let A be the event of getting an even number

$$\therefore A = \{2, 4, 6, 8, 10, 12, 14, 16, 18, 20, 22, 24, 26, 28, 30\}$$

$$\therefore n(A) = 15$$

Therefore, the probability of getting an even number =  $\frac{n(A)}{n(S)} = \frac{15}{30} = \frac{1}{2}$

ii. Let B be the event of getting a number divisible by 2 and 3. To get the numbers which are divisible by 2 and 3 both, we need to find the numbers which are divisible by 6.

$$\therefore B = \{6, 12, 18, 24, 30\}$$

$$\therefore n(B) = 5$$

Therefore, the probability of getting a number divisible by 2 and 3 =  $\frac{n(B)}{n(S)} = \frac{5}{30} = \frac{1}{6}$

iii. Let C be the event of getting a number less than 18.

$$\therefore C = \{1, 2, 3, 4, 5, 6, 7, 8, 9, 10, 11, 12, 13, 14, 15, 16, 17\}$$

$$\therefore n(C) = 17$$

Therefore, the probability of getting a number less than 16 =  $\frac{n(C)}{n(S)} = \frac{17}{30}$

(b) Priya opened a recurring deposit account for 22 months. The rate of interest is 10% per annum and Priya receives Rs. 500 as interest at the time of maturity. Find the amount Priya deposited each month. [3]

Ans.

Given, Rate of interest given by bank (r) = 10%

Time period (n) = 22 months

Interest at the time of maturity = Rs.500

Let, the principle deposited every month be P

According to question,

$$\begin{aligned}P \frac{n(n+1)}{2} \times \frac{r}{12 \times 100} &= 500 \\ \Rightarrow P \frac{22(23+1)}{2} \times \frac{10}{1200} &= 500 \\ \Rightarrow P \frac{20 \times 21}{2} \times \frac{10}{1200} &= 500 \\ \Rightarrow P &= \frac{500 \times 2 \times 1200}{20 \times 21 \times 10} \\ \therefore P &= 285.72\end{aligned}$$

Therefore, the amount deposited by Priya each month is Rs 285.72.

(c) Use a graph sheet for this question. [4]

Take 1 cm = 1 unit along both x and y axis.

(i) Plot the following points:

A(0,5), B(3,0), C(1,0), and D(1,-5)

(ii) Reflect the points B, C, and D on the y axis and name them as B', C' and D' respectively.

(iii) Write down the coordinates of B', C' and D'.

(iv) Join the points A, B, C, D, D', C', B', A in order and give a name to the closed figure ABCDD'C'B'.

Ans.

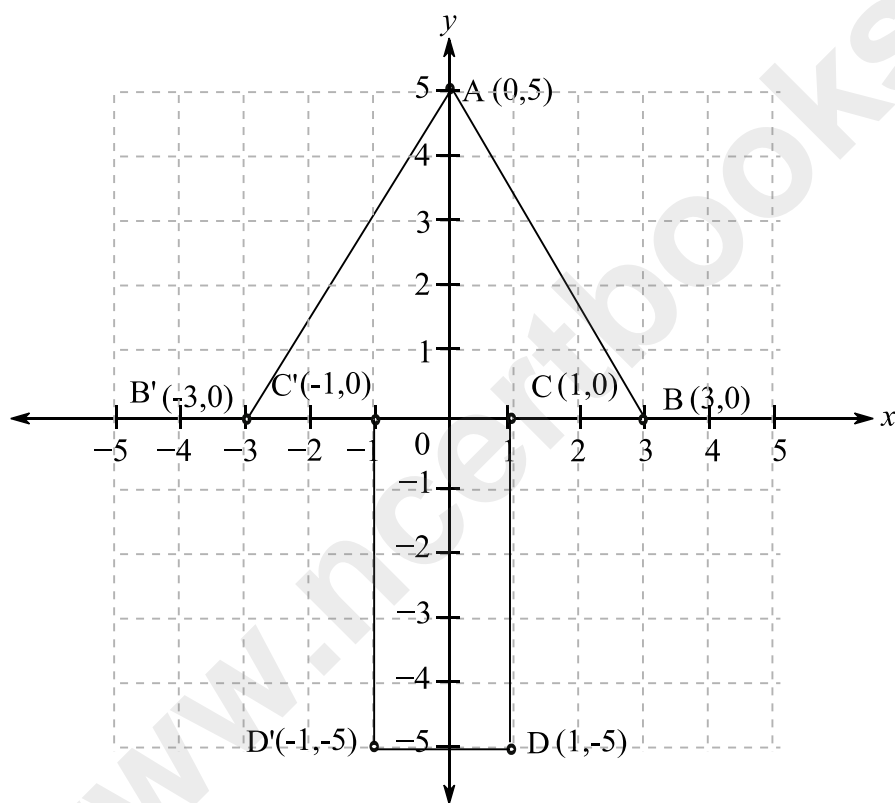

### Question 6

(a) In the given figure  $\angle PQR = \angle PST = 90^\circ$ ,  $PQ = 4$  cm and  $PS = 3$  cm. [3]

(i) Prove that  $\triangle PQR = \triangle PST$

(ii) Find Area of  $\triangle PQR$ : Area of quadrilateral SRQT.

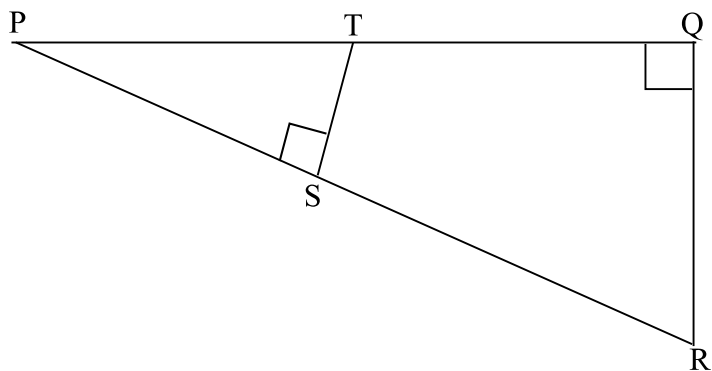

**Ans.**

Given,  $PQ = 4\text{cm}$  and  $PS = 3\text{cm}$

(i). Here, in  $\triangle PQR$  and  $\triangle PST$

$$\angle PQR = \angle PST = 90^\circ$$

And  $\angle RPQ = \angle SPT$  [  $\because$  Being common angle]

$\therefore \triangle PQR \sim \triangle PST$  [Being AA similarity]

$$\text{So, } \frac{PQ}{PS} = \frac{QR}{ST} = \frac{PR}{PT} = \frac{4}{3}$$

$$\therefore \frac{\text{ar}(\triangle PQR)}{\text{ar}(\triangle PST)} = \frac{4^2}{3^2} = \frac{16}{9}$$

$$\therefore \text{ar}(\triangle PST) = \frac{9}{16} \text{ar}(\triangle PQR) \dots \dots \dots \text{eq(1)}$$

(ii)

$$\frac{ar(\Delta PQR)}{ar(\Delta PST)} = \frac{4^2}{3^2} = \frac{16}{9}$$

$$\frac{ar(\Delta PQR) - ar(\Delta PST)}{ar(\Delta PST)} = \frac{16 - 9}{9} = \frac{7}{9}$$

$$\frac{ar(\square SRQT)}{ar(\Delta PST)} = \frac{7}{9}$$

$$\frac{ar(\square SRQT)}{\frac{9}{16} ar(\Delta PQR)} = \frac{7}{9} \dots\dots\dots \text{From equation 1}$$

$$\frac{ar(\square SRQT)}{ar(\Delta PQR)} = \frac{7}{9} \times \frac{9}{16}$$

$$\frac{ar(\square SRQT)}{ar(\Delta PQR)} = \frac{7}{16}$$

**(b) The first and last term of a Geometrical Progression (G.P.) are 3 and 96 respectively. If the common ratio is 2, find: [3]**

- (i) 'n' the number of terms of the G.P.**
- (ii) Sum of the n terms.**

Ans. Given first term (a) = 4, last term (l) = 128 and common difference (r) = 2.

(i). We know, formula to find nth term of a G.P is  $a_n = ar^{n-1}$  or  $l = ar^{n-1}$

So, according to question,

$$128 = 4 \times 2^{n-1}$$

$$\Rightarrow 2^{n-1} = 32$$

$$\Rightarrow 2^{n-1} = (2)^5$$

$$\Rightarrow n - 1 = 5$$

$$\therefore n = 6$$

(ii). We have,  $n=6$ ,  $r=2$  and  $a=4$

Formula for the sum of  $n$  terms of a G.P ( $S_n$ ) =  $\frac{a(r^n - 1)}{r - 1}$

$$\begin{aligned}\therefore \text{Sum of 6 terms } (S_6) &= \frac{4(2^6 - 1)}{2 - 1} \\ &= \frac{4(64 - 1)}{1} \\ &= 4 \times 63 = 252\end{aligned}$$

(c) A hemispherical and a conical hole is scooped out of a solid wooden cylinder. Find the volume of the remaining solid where the measurements are as follows: The height of the solid cylinder is 7 cm, radius of each of hemisphere, cone and cylinder is 3 cm. Height of cone is 3 cm. Give your answer correct to the nearest whole number Take

$$\pi = \frac{22}{7}$$

[4]

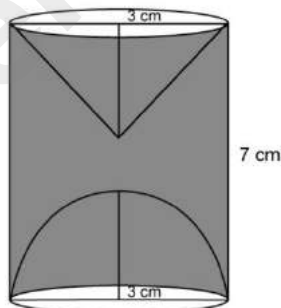

**Ans.**

Given, Height of cylinder ( $h$ ) = 7cm

Radius ( $r$ ) = 3cm

$$\therefore \text{Volume of cylinder } (V_1) = \pi r^2 h$$

$$= \pi(3)^2 7 = \pi.63cm^3$$

Height of cone ( $H$ ) = 3cm

$$\therefore \text{Volume of cone } (V_2) = \frac{1}{3} \pi r^2 H$$

$$= \frac{1}{3} \pi (3)^2 3 = \pi 9 \text{cm}^3$$

$$\text{Volume of hemisphere } (V_3) = \frac{2}{3} \pi r^3$$

$$= \frac{2}{3} \pi (3)^3 = \pi 18 \text{cm}^3$$

According to question,

$$\text{Volume of remaining solid} = V_1 - V_2 - V_3$$

$$\begin{aligned} \therefore \text{Remaining volume} &= \pi \cdot 63 - \pi 9 - \pi 18 \\ &= \pi (63 - 9 - 18) \\ &= \frac{22}{7} \times 36 \\ &= 113.14 \text{cm}^3 \end{aligned}$$

### Question 7

(a) In the given figure AC is a tangent to the circle with centre O. If  $\angle ADB = 55^\circ$ , find x and y, Give reasons for your answer. [3]

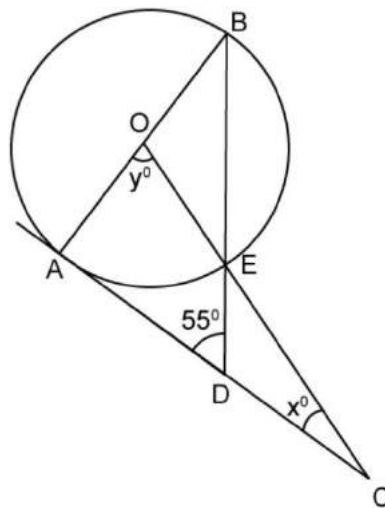

**Ans.**

Given that, AC is a tangent to the circle with centre O

And  $\angle ADB = 55^\circ$

Here,  $\triangle ABD$  is a right angled triangle, so  $\angle BAD = 90^\circ$

We know,

Sum of interior angles of a triangle =  $180^\circ$

$$\angle ADB + \angle BAD + \angle ABD = 180^\circ$$

$$\Rightarrow 55^\circ + 90^\circ + \angle ABD = 180^\circ$$

$$\Rightarrow \angle ABD = 180^\circ - 145$$

$$\therefore \angle ABD = 35^\circ$$

Since,  $\angle AOE$  is subtended at the centre and  $\angle EBA$  on the circle by the arc AE,

Thus,  $2\angle ABD = \angle AOE$

$$\angle AOE = 2 \times 35$$

$$\therefore y = 70^\circ$$

In  $\triangle AOC$ ,  $\angle OAC = 90^\circ$

$\therefore$  Sum of interior angles of triangle =  $180^\circ$

$$\therefore \angle OAC + \angle AOC + \angle ACO = 180^\circ$$

$$\Rightarrow 90^\circ + y + x = 180^\circ$$

$$\Rightarrow x + y = 90^\circ$$

$$\Rightarrow x - 35^\circ = 90$$

$$\therefore x = 55^\circ$$

**(b) The model of a building is constructed with scale factor 1: 30. [3]**

**(i) If the height of the model is 50 cm, find the actual height of the building in meters.**

**(ii) If the actual volume of a tank at the top of the building is  $27m^3$ , find the volume of the tank on the top of the model.**

**Ans.** Given scale factor is 1:30

(i). The ratio of height of the model and building is 1:30

So, if height of the model is 50cm

Then, the actual height of the building =  $50 \times 30 = 1500 \text{ cm} = 24\text{m}$

(i). Given, actual volume of tank =  $27\text{m}^3$

Given scale factor = 1:30

Here,

$$1\text{m} = \frac{10}{3}\text{cm}$$

$$(1\text{m})^3 = \left(\frac{10}{3}\right)^3$$

$$1\text{m}^3 = \frac{1000}{27}\text{cm}^3$$

$$\text{Then, } 27\text{m}^3 = \frac{1000}{27} \times 27 = 1000\text{cm}^3$$

Now,

$$1\text{cm}^3 = 0.001\text{litres}$$

$$\therefore 1000\text{cm}^3 = 0.001 \times 1000 = 1\text{litres}$$

Therefore, the required volume of model tank is 1litres.

(c) Given,  $\begin{vmatrix} 6 & 4 \\ -1 & 1 \end{vmatrix} \mathbf{M} = 10\mathbf{I}$ , where  $\mathbf{M}$  is a matrix and  $\mathbf{1}$  is unit matrix of order  $2 \times 2$ . [4]

(i) State the order of matrix  $\mathbf{M}$ .

(ii) Find the matrix  $\mathbf{M}$

Ans.

$$(i) \begin{vmatrix} 6 & 4 \\ -1 & 1 \end{vmatrix} \mathbf{M} = 10\mathbf{I}$$

For matrix multiplication, the number of columns in first matrix should be equal to the number of rows in the other matrix and the resulting matrix will have order as below:

$$\begin{vmatrix} | & | \\ m \times n & \times \\ | & | \\ n \times q & \\ | & | \\ m \times q & \end{vmatrix} = \begin{vmatrix} | & | \\ m \times q & \end{vmatrix}$$

As given:

$$\begin{vmatrix} 6 & 4 \\ -1 & 1 \end{vmatrix} M = \begin{vmatrix} 10 & 0 \\ 0 & 10 \end{vmatrix}$$

So, the order of M should be 2 x 2

$$\text{Let } M = \begin{vmatrix} p & q \\ r & s \end{vmatrix}$$

$$\begin{vmatrix} 6 & 4 \\ -1 & 1 \end{vmatrix} M = \begin{vmatrix} 6 & 4 \\ -1 & 1 \end{vmatrix} \times \begin{vmatrix} p & q \\ r & s \end{vmatrix} = \begin{vmatrix} 6p + 4r & 6q + 4s \\ -p + r & -q + s \end{vmatrix}$$

$$\Rightarrow \begin{vmatrix} 6p + 4r & 6q + 4s \\ -p + r & -q + s \end{vmatrix} = \begin{vmatrix} 10 & 0 \\ 0 & 10 \end{vmatrix}$$

$$6p + 4r = 10 \dots \dots \dots \text{eq1}$$

$$-p + r = 0 \dots \dots \dots \text{eq2}$$

$$6q + 4s = 0 \dots \dots \dots \text{eq3}$$

$$-q + s = 10 \dots \dots \dots \text{eq4}$$

From eq2 we get,

$$r = p$$

Substituting the value of r in eq1

$$6r + 4r = 10$$

$$10r = 10$$

$$r = 1$$

$$\Rightarrow p = 1$$

From eq4 we get,

$$s = 10 + q$$

Substituting the value of r in eq3

$$6q + 4(10 + q) = 0$$

$$6q + 40 + 4q = 0$$

$$10q = -40$$

$$q = -4$$

$$\Rightarrow s = 10 - 4 = 6$$

Therefore,  $M = \begin{vmatrix} 1 & -4 \\ 1 & 6 \end{vmatrix}$

**Question 8**

**(a) The sum of the first three terms of an Arithmetic Progression (A.P.) is 90 and the product of the first and third term is 875. Find the first term and the common difference. [3]**

**Ans.** Let the first term of A.P be  $a$  and the common difference be  $d$ .  
So, the first three terms could be  $a-d$ ,  $a$ , and  $a+d$ .

According to question,

$$a-d+a+a+d=90$$

$$\Rightarrow 3a=90$$

$$\therefore a = \frac{90}{3}=30 \dots\dots\dots(1)$$

And,

$$(a-d)(a+d)=875$$

$$\Rightarrow a^2-d^2=875 \quad [ \because (a+b)(a-b) = a^2 - b^2 ]$$

Putting value of  $a$  from (1), we get

$$\Rightarrow (30)^2 - d^2 = 875$$

$$\Rightarrow 900 - 875 = d^2$$

$$\Rightarrow d^2 = 25$$

$$\therefore d = 5$$

**(b) The vertices of a  $\Delta ABC$  are  $A(2, 7)$ ,  $B(-2, 3)$  and  $C(4, -6)$ , Find: [3]**

**(i) Slope of BC.**

**(ii) Equation of a line perpendicular to BC and passing through A.**

**Ans.** Given, the vertices of triangle ABC are  $A(2, 7)$ ,  $B(-2, 3)$  and  $C(4, -6)$ ,

i.e. know, slope of line =  $\frac{y_2 - y_1}{x_2 - x_1}$

$$\therefore \text{Slope of BC} = \frac{-6 - 3}{4 - (-2)} = \frac{-9}{6} = -\frac{3}{2}$$

ii. Let AE be the line which is perpendicular to BC and passes through A

So, Slope of AE =  $-\frac{1}{\text{Slope of BC}}$  [  $\because$  AE is perpendicular to BC ]

$$\therefore \text{Slope of AE} = -\left(\frac{1}{-\frac{3}{2}}\right) = \frac{2}{3}$$

Now, we have

Slope of AE (m) =  $\frac{2}{3}$  and A (2,7)

$\therefore$  Equation of line AE

$$= y - 7 = \frac{2}{3}(x - 2)$$

$$\Rightarrow 3y - 21 = 2x - 4$$

$$\Rightarrow 3y - 21 - 2x + 4 = 0$$

$$\Rightarrow 3y - 2x - 17 = 0$$

**(c) Using ruler and a compass only construct a semi-circle with diameter BC = 7cm. Locate a point A on the circumference of the semicircle such that A is equidistant from B and C. Complete the cyclic quadrilateral ABCD, such that D is equidistant from AB and BC. Measure  $\angle ADC$  and write it down. [4]**

**Ans.**

- 1) Construct a semi-circle with diameter  $BC = 7$  cm i.e. radius 3.5 cm
- 2) Draw the perpendicular bisector of  $BC$  and extend it to touch the semi-circle
- 3) Mark this point as  $A$  (Since  $A$  should be equidistant from  $B$  and  $C$ )
- 4) Join  $AB$  and  $AC$
- 5) Draw the angle bisector of angle  $ABC$  and extend it to meet the semi-circle
- 6) Mark this point as  $D$  ( $D$  is equidistant from  $AB$  and  $BC$ )
- 7) Join  $AD$  and  $CD$
- 8) Measure of  $\angle ADC$  is  $135^\circ$

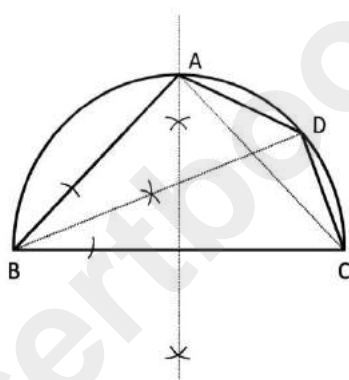

**Question 9**

(a) The data on the number of patients attending a hospital in a month are given below. Find the average (mean) number of patients attending the hospital in a month by using the shortcut method. [3]

Take the assumed mean as 45. Give your answer correct to 2 decimal places.

Number of patients	10-20	20-30	30-40	40-50	50-60	60-70
Number of days	4	5	3	8	3	2

**Ans.** Given, Assumed mean ( $A$ ) = 45

The frequency table can be obtained using the data above:

Number of patients	Mid-point(x)	Number of days(f)	d = x-A =x- 45	fd
10-20	15	4	-30	-120
20-30	25	5	-20	-100
30-40	35	3	-10	-30
40-50	45	8	0	0
50-60	55	3	10	30
60-70	65	2	20	140
		$\sum f = 25$		$\sum fd = 80$

We have formula for mean =  $A + \frac{\sum fd}{\sum f}$

$\therefore$  Mean number of patients attending the hospital in a day

$$= 45 + \frac{80}{25} = 45 + 3.2 = 48.2$$

Hence, the mean or average number of patients attending the hospital in a month

$$= 48.2 \times 30$$

$$= 1446$$

**(b) Using properties of proportion solve for x, given. [3]**

$$\frac{\sqrt{7x} + \sqrt{5x-4}}{\sqrt{7x} - \sqrt{5x-4}} = 2$$

**Ans.** Given,  $\frac{\sqrt{7x} + \sqrt{5x-4}}{\sqrt{7x} - \sqrt{5x-4}} = 2$

Using rationalization, we get

$$\frac{\sqrt{7x} + \sqrt{5x-4}}{\sqrt{7x} - \sqrt{5x-4}} \times \frac{\sqrt{7x} + \sqrt{5x-4}}{\sqrt{7x} + \sqrt{5x-4}} = 2$$

$$\Rightarrow \frac{(\sqrt{7x})^2 + (\sqrt{5x-4})^2}{(\sqrt{7x})^2 - (\sqrt{5x-4})^2} = 2$$

$$\Rightarrow \frac{7x + 2\sqrt{7x}\sqrt{5x-4} + 5x - 4}{7x - 5x + 4} = 2$$

$$\Rightarrow 12x + 2\sqrt{7x}\sqrt{5x-4} - 4 = 2(2x + 4)$$

$$\Rightarrow 12x + 2\sqrt{7x}\sqrt{5x-4} - 4 = 4x + 8$$

$$\Rightarrow 2\sqrt{7x}\sqrt{5x-4} = -8x + 12$$

Squaring both the sides, we get

$$(2\sqrt{7x}\sqrt{5x-4})^2 = (-8x + 12)^2$$

$$\Rightarrow 4 \times 7x(5x-4) = 64x^2 - 192x + 144$$

$$\Rightarrow 28x(5x-4) = 64x^2 - 192x + 144$$

$$\Rightarrow 140x^2 - 112x - 64x^2 + 192x = 144$$

$$\Rightarrow 76x^2 - 80x - 144 = 0$$

$$\Rightarrow 19x^2 - 20x - 36 = 0$$

$$\Rightarrow 19x^2 - 38x + 18x - 36 = 0$$

$$\Rightarrow 19x(x-2) + 18(x-2) = 0$$

$$\Rightarrow (x-2)(19x+18) = 0$$

Either,

$$x - 2 = 0$$

$$x = 2$$

Or

$$19x + 18 = 0$$

$$x = \frac{-18}{19}$$

**(c) Rahul invests Rs. 8400 in 12%, Rs. 100 shares at Rs. 120 He sells the shares when the price of each share rises by Rs. 30. He invests the proceeds in 5% Rs. 100 shares at Rs. 105, Find:[4]**

- (i) The sale proceeds**
- (ii) The number of Rs. 105 shares he buys.**
- (iii) The change in his annual income.**

**Ans.**

Purchase price of each share = Rs. 120

Then, number shares purchased for Rs.8400 =  $\frac{8400}{120} = 70$

As the price of share increases by Rs. 30,

So,

Selling price of each share = Rs. (120 +30) = Rs.150

i. Sale proceeds shares = Rs. (150 × 70) = Rs. 10500

ii. The number of shares purchased at Rs. 105 each =  $\frac{10500}{105} = 100$

iii. Initially,

Total face value of share = Face value of each share × numbers of share  
= 100 × 70 = Rs.7000

Dividend = 12% of total face value

$$= \frac{12}{100} \times 7000 = \text{Rs.}840$$

After the price of share rises by Rs.30,

Total face value of share = 100 × 100 = Rs. 10000

And, Dividend = 5% of 10000 =  $\frac{5}{100} \times 10000 = \text{Rs.}500$

Hence, the change in annual income = Rs.(840-500) =Rs. 340

### Question 10

(a) Use graph paper for this question. The marks obtained by 120 students in an English test are given below. [6]

Marks	0-10	10-20	20-30	30-40	40-50	50-60	60-70	70-80	80-90	90-100
No. of students	5	9	16	22	26	18	11	6	4	3

Draw the ogive and hence, estimate:

(i) The median marks.

(ii) The number of students who did not pass the test if the pass percentage was 50.

(iii) The upper quartile marks.

Ans. We have to prepare a frequency table first,

Class Interval	Frequency	Cumulative frequency
0-10	5	5
10-20	9	14
20-30	16	30
30-40	22	52
40-50	26	78
50-60	18	96
60-70	11	107
70-80	6	113
80-90	4	117
90-100	3	120

Here,  $n = 120$  and  $\frac{n}{2} = \frac{120}{2} = 60$

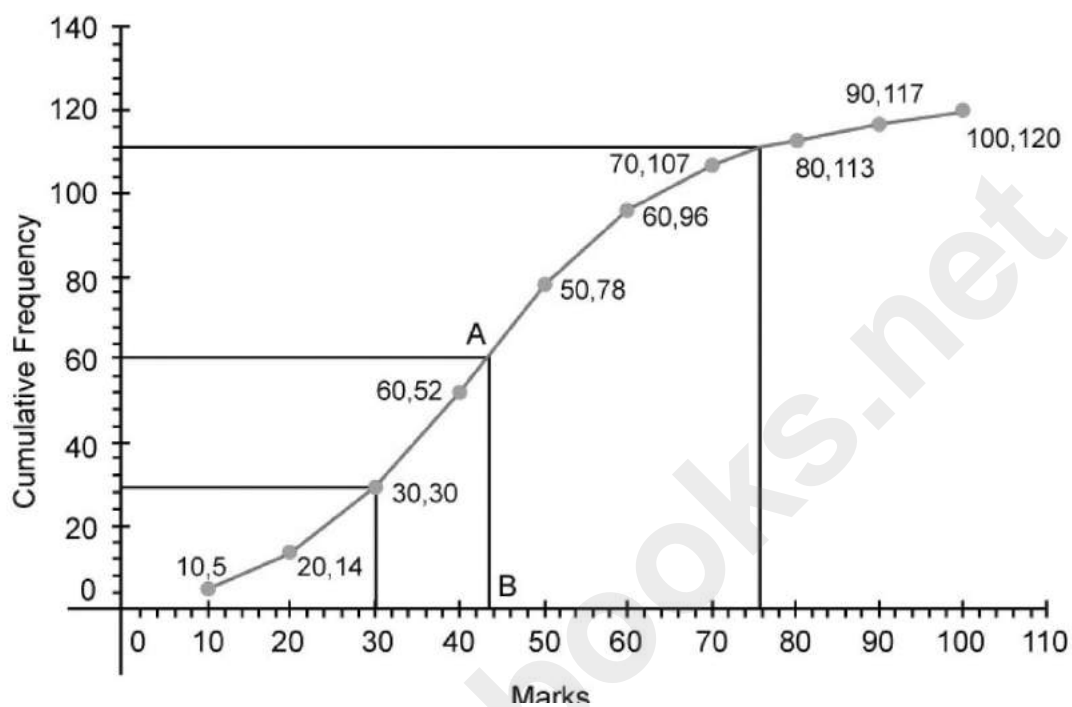

i. Through mark 60, draw a line segment parallel to x-axis which meets the curve at A. From A, draw a line parallel to y-axis which meets the x-axis at point B. Therefore,

Median = 43

ii. Number of students who did not pass the test = the students who obtained less than 50 % marks =  $5+9+16+22+26=78$

iii. The formula for upper quartile =  $\left(\frac{3n}{4}\right)^{th}$  term.

Therefore, the upper quartile marks =  $\left(\frac{3 \times 120}{4}\right)^{th}$  term =  $90^{th}$  term = 117

(b) A man observes the angle of elevation of the top of the tower to be  $45^\circ$ . He walks towards it in a horizontal line through its base. On covering 20 m the angle of elevation changes to  $60^\circ$ . Find the height of the tower correct to 2 significant figures. [4]

**Ans.**

Let PQ be the height of the tower and R and S be two positions of man from where the angle of elevation was formed.

According to question, RS = 20m,  $\angle QSP = 45^\circ$  and  $\angle QRP = 60^\circ$

Let PQ = h and RP = x

Then, in  $\triangle QSP$ ,

$$\tan 45^\circ = \frac{PQ}{SP}$$

$$\Rightarrow \tan 45^\circ = \frac{h}{20+x} \quad [ \because \text{Being right angled triangle \& } \tan 45^\circ = 1 ]$$

$$\Rightarrow 20+x = h$$

$$\Rightarrow x = h - 20$$

Similarly, in  $\triangle PQR$

$$\tan 60^\circ = \frac{PQ}{RP}$$

$$\Rightarrow \sqrt{3} = \frac{h}{x}$$

$$\Rightarrow x = \frac{h}{\sqrt{3}}$$

Now, we can write,  $h - 20 = \frac{h}{\sqrt{3}}$  [Combining the above equations]

$$\begin{aligned} \Rightarrow \sqrt{3}(h-20) &= h \\ \Rightarrow \sqrt{3}h - 20\sqrt{3} &= h \\ \Rightarrow \sqrt{3}h - h &= 20\sqrt{3} \\ \Rightarrow h(\sqrt{3}-1) &= 20\sqrt{3} \\ \Rightarrow h &= \frac{20\sqrt{3}}{(\sqrt{3}-1)} \\ \therefore h &= 47.32 \end{aligned}$$

Hence, the height of the tower is 47.32m.

### Question 11

(a) Using the Remainder Theorem find the remainders obtained when  $x^3 + (kx + 8)x + k$  is divided by  $x + 1$  and  $x - 2$ . Hence find  $k$  if the sum of the two remainders is 1. [3]

**Ans.**

Let  $P(x)$  be a polynomial

So, we have  $P(x) = x^3 + (kx + 8)x + k$

When  $P(x)$  is divided by  $(x+1)$  and  $(x-2)$ , the remainder is  $P(-1)$  and  $P(2)$  respectively.

$$\begin{aligned} \text{Now, } P(-1) &= (-1)^3 + [k(-1) + 8](-1) + k \\ &= -1 + (k - 8) + k \\ &= 2k - 9 \end{aligned} \quad \begin{aligned} \text{And, } P(2) &= (2)^3 + [k(2) + 8]2 + k \\ &= 8 + (2k + 8)2 + k \\ &= 8 + 4k + 16 + k \\ &= 5k + 24 \end{aligned}$$

According to question, the sum of the two remainders is 1

i.e.

$$P(-1) + P(2) = 1$$

$$\Rightarrow (2k-9) + (5k+24) = 1$$

$$\Rightarrow 2k-9+5k+24=1$$

$$\Rightarrow 7k+15=1$$

$$\Rightarrow 7k = -14$$

$$\therefore k = -2$$

**(b) The product of two consecutive natural numbers which are multiples of 3 is equal to 810. Find the two numbers. [3]**

**Ans.** Let the two consecutive natural numbers which are multiple of 3 be  $3x$  and  $(3x+3)$

Then, according to question,

Product of the numbers = 810

$$\Rightarrow 3x \times (3x + 3) = 810$$

$$\Rightarrow 9x^2 + 9x = 810$$

$$\Rightarrow x^2 + x = 90$$

$$\Rightarrow x^2 + x - 90 = 0$$

$$\Rightarrow x^2 + 10x - 9x + 90 = 0$$

$$\Rightarrow x(x+10) - 9(x+10) = 0$$

$$\Rightarrow (x+10)(x-9) = 0$$

$$\therefore x = -10 \text{ or } 9$$

Taking  $x=9$ , we get  $3x = 3 \times 9 = 27$

And  $(3x+3) = (3 \times 9 + 3) = 30$

Taking  $x = -10$ , we get  $3x = 3 \times -10 = -30$

And,  $(3x+3) = [3 \times (-10) + 3] = -27$

Hence, the required numbers are 27 and 30 or -27 and -30

(c) In the given figure, ABCDE is a pentagon inscribed in a circle such that AC is a diameter and side  $BC \parallel AE$ . If  $\angle BAC = 50^\circ$ , find giving reasons: [4]

(i)  $\angle ACB$

(ii)  $\angle EDC$

(iii)  $\angle BEC$

Hence prove that BE is also a diameter.

**Ans.** Given that, ABCDE is a pentagon inscribed in a circle such that AC is the diameter of circle and  $BC \parallel AE$ .

And,  $\angle BAC = 50^\circ$

Here,  $\triangle ABC$  is right angled triangle, so  $\angle ABC = 90^\circ$

Now,

$$\angle ABC + \angle BAC + \angle ACB = 180^\circ$$

$$\Rightarrow 90^\circ + 50^\circ + \angle ACB = 180^\circ$$

[Sum of interior angles of triangle =  $180^\circ$ ]

$$\Rightarrow \angle ACB = 180^\circ - 140^\circ$$

$$\therefore \angle ACB = 40^\circ$$

Since,  $BC \parallel AE$

$$\therefore \angle ACB = \angle EAC = 40^\circ \quad [\text{Being alternate angle}]$$

Again, in  $\triangle AEC$ ,  $\angle AEC = 90^\circ$

[Sum of interior angles of triangle =  $180^\circ$ ]

$$\angle AEC + \angle EAC + \angle ACE = 180^\circ$$

$$\Rightarrow 90^\circ + 40^\circ + \angle ACE = 180^\circ$$

$$\Rightarrow \angle ACE = 180^\circ - 130^\circ$$

$$\therefore \angle ACE = 50^\circ$$

And,  $\angle BAC = 50^\circ$

Therefore,  $AB \parallel CE$

[ $\therefore$  Being alternate angles made by transversal AC with lines CE&AB,equal]

$$\text{Now, } \angle BAE = 50^\circ + 40^\circ = 90^\circ$$

Also, since  $\angle EAB$  is subtended by EB on the circle  
So, BE is a diameter of the given circle.

Here, AEDC is cyclic quadrilateral

So,

$$\angle EAC + \angle EDC = 180^\circ$$

$$\Rightarrow 40^\circ + \angle EDC = 180^\circ$$

$$\therefore \angle EDC = 140^\circ$$

Now,

We see that Arc BC subtends angles  $\angle BAC$  and  $\angle BEC$  on the same side of the circle

Therefore,

$$\angle BAC = \angle BEC = 50^\circ$$