

**ICSE Board  
Class X Chemistry  
Science Paper – II  
Semester 1 Examination  
Board Paper – 2021**

**Time: 1 hour**

**Maximum Marks: 40**

*Maximum Marks: 40*

*Time allowed: one hour*

*You will not be allowed to write during the first 10 minutes.*

*This time is to be spent in reading the question paper.*

**ALL QUESTIONS ARE COMPULSORY**

*The intended marks for questions or parts of questions are given in brackets [ ].*

**Select the correct option for each of the following questions.**

**Question 1**

In the periodic Table, elements of period 3 are arranged in the increasing order of ionization potential as: [1]

- (a) B, N, Cl, Ar
- (b) Mg, Si, S, Ar
- (c) Ar, Si, S, Mg
- (d) Si, Ar, Cl, Mg

**Question 2**

If Relative Molecular Mass of Butane ( $C_4H_{10}$ ) is 58 then its vapour density will be: [1]

- (a) 58
- (b) 29
- (c) 32
- (d) 16

**Question 3**

Identify one statement that holds true for electrolysis of molten lead bromide: [1]

- (a) Silver grey metal deposits at the anode
- (b) Temperature is not maintained during the electrolysis
- (c) Brown vapours of bromine are obtained at the anode.
- (d) Electrolyte contains  $H^+$  ions along with  $Pb^{2+}$  ions

**Question 4**

The tendency of an atom to attract shared pair of electrons to itself when forming a chemical bond is known as: [1]

- (a) Electron affinity
- (b) Electronegativity
- (c) Ionization potential
- (d) Nuclear charge

**Question 5**

Solid sodium chloride **does not** conduct electricity as: [1]

- (a) The strength of the bond is weak
- (b) It contains free ions
- (c) It does not contain any free ions
- (d) It contains free ions as well as molecules

**Question 6**

Elements A and B have electronic configurations 8 and 13 respectively. The chemical formula formed between A and B will be: [1]

- (a) AB
- (b) B<sub>3</sub>A<sub>3</sub>
- (c) A<sub>2</sub>B<sub>3</sub>
- (d) B<sub>2</sub>A<sub>3</sub>

**Question 7**

The percentage of hydrogen present in NaOH is: (Relative Molecular Mass of NaOH = 40) (At. Wt. of H = 1) [1]

- (a) 2.5
- (b) 25
- (c) 0.25
- (d) 0.025

**Question 8**

A salt formed by incomplete neutralization of an acid by a base: [1]

- (a) Basic salt
- (b) Acid salt
- (c) Normal salt
- (d) Complex salt

**Question 9**

The colour of the precipitate formed after the addition of a small amount of sodium hydroxide solution to an aqueous solution of ferric chloride is: [1]

- (a) gelatinous white
- (b) pale blue
- (c) reddish brown
- (d) dirty green

**Question 10**

Alkaline earth metals have the same: [1]

- (a) number of valence electrons
- (b) number of shells
- (c) metallic property
- (d) ionization potential

**Question 11**

Which of the following compounds neither dissociate nor ionise in water? [1]

- (a) Hydrochloric acid
- (b) Sodium hydroxide
- (c) Potassium Nitrate
- (d) Carbon tetrachloride

**Question 12**

The table shows the electronic configuration of four elements. [1]

element	electronic configuration
W	2, 6
X	2, 8
Y	2, 8, 1
Z	2, 8, 7

Which pair of atoms will form a covalent compound?

- (a) two atoms of W
- (b) two atoms of X
- (c) an atom of W and an atom of X
- (d) an atom of Y and an atom of Z

**Question 13**

Element with an atomic number 19 will: [1]

- (a) accept an electron and get oxidized
- (b) accept an electron and get reduced
- (c) lose an electron and get oxidized
- (d) lose an electron and get reduced

**Question 14**

Which of the following has two sets of lone pair of electrons in them? [1]

- (a) Ammonia
- (b) Methane
- (c) Water
- (d) Ammonium ion

**Question 15**

If the empirical mass of the formula  $PQ_2$  is 10 and the Relative Molecular Mass is 30, then the molecular formula will be: [1]

- (a)  $PQ_2$
- (b)  $P_3Q_2$
- (c)  $P_6Q_2$
- (d)  $P_3Q_6$

**Question 16**

Which of the following is a tribasic acid?

[1]

- (a)  $\text{H}_2\text{SO}_4$
- (b)  $\text{Al}(\text{OH})_3$
- (c)  $\text{H}_3\text{PO}_4$
- (d)  $\text{Ca}(\text{OH})_2$

**Question 17**

If a solution of an electrolyte mixture has calcium ions, cupric ions, zinc ions and magnesium ions, which of these ions would you see preferentially discharged at the cathode?

[1]

- (a) Calcium ions
- (b) Zinc ions
- (c) Cupric ions
- (d) Magnesium ions

**Question 18**

Which of the following ions will readily discharge at the anode during the electrolysis of acidulated water?

[1]

- (a)  $\text{OH}^-$
- (b)  $\text{SO}_4^{2-}$
- (c)  $\text{Cl}^-$
- (d)  $\text{H}^+$

**Question 19**

If the empirical formula of a compound is  $\text{CH}$  and its vapour density is 13, then its molecular formula will be:

[1]

(At. Wt.  $\text{C}=12$ ,  $\text{H}=1$ )

- (a)  $\text{CH}$
- (b)  $\text{C}_2\text{H}_2$
- (c)  $\text{C}_4\text{H}_4$
- (d)  $\text{C}_3\text{H}_3$

**Question 20**

Aqueous solution of Cupric chloride forms a deep blue solution on addition of:

[1]

- (a) dropwise sodium hydroxide
- (b) excess sodium hydroxide
- (c) dropwise ammonium hydroxide
- (d) excess ammonium hydroxide

**Question 21**

Which statement about conduction of electricity is correct?

[1]

- (a) Electricity is conducted in aqueous solution by electrons
- (b) Electricity is conducted in a metal wire by ions
- (c) Electricity is conducted in a molten electrolyte by electrons
- (d) Electricity is conducted in an acid solution by ions

**Question 22**

If an element has low ionization potential, then it is likely to be a: [1]

- (a) metal
- (b) metalloid
- (c) non metal
- (d) inert gas

**Question 23**

Which electron arrangement for the outer shell electrons in a covalent compound is correct? [1]

- (a)  $\begin{array}{c} \times \times \quad \bullet \bullet \\ \text{H} \times \text{C} \text{I} \bullet \bullet \\ \bullet \bullet \end{array}$
- (b)  $\begin{array}{c} \times \times \quad \bullet \bullet \\ \times \text{H} \times \text{C} \text{I} \bullet \bullet \\ \times \times \quad \bullet \bullet \end{array}$
- (c)  $\begin{array}{c} \bullet \bullet \\ \text{H} \times \text{N} \times \text{H} \\ \times \times \\ \text{H} \end{array}$
- (d)  $\begin{array}{c} \bullet \bullet \\ \text{H} \times \text{N} \times \text{H} \\ \times \times \\ \text{H} \end{array}$

**Question 24**

The products formed when an acid reacts with a base is: [1]

- (a) salt and hydrogen
- (b) salt and oxygen
- (c) salt and water
- (d) salt and carbon dioxide

**Question 25**

In the circuit below, the lamp lights up. [1]

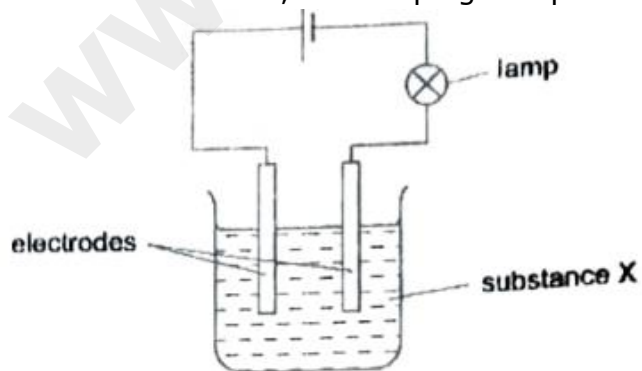

What could X be?

- (a) a solution of alcohol in water
- (b) a solution of sodium chloride in water
- (c) sugar solution
- (d) solid potassium chloride

**Question 26**

Which one of the following is a non-metallic cation? [1]

- (a)  $K^+$
- (b)  $NH_4^+$
- (c)  $Cu^{2+}$
- (d)  $Na^+$

**Question 27**

Type of bonding present in hydrogen chloride: [1]

- (a) metallic
- (b) ionic
- (c) covalent
- (d) coordinate

**Question 28**

The non-metallic properties of elements from left to right in a Periodic Table: [1]

- (a) increases
- (b) decreases
- (c) remains same
- (d) first increases and then decreases

**Question 29**

The aqueous solution that contains both ions and molecules: [1]

- (a) sulphuric acid
- (b) nitric acid
- (c) acetic acid
- (d) hydrochloric acid

**Question 30**

The basic oxide which is an alkali: [1]

- (a) Copper oxide
- (b) Sodium oxide
- (c) Ferric oxide
- (d) Zinc oxide

**Question 31**

If the pH of a solution is '2', then solution is a: [1]

- (a) strong acid
- (b) strong alkali
- (c) weak acid
- (d) weak alkali

**Question 32**

The acidity of aluminium hydroxide is:

[1]

- (a) 3
- (b) 1
- (c) 4
- (d) 2

**Question 33**

Hydracids are those acids which contain:

[1]

- (a) Hydrogen with any metal
- (b) Hydrogen, a non-metal and oxygen
- (c) Hydrogen and a non-metal other than oxygen
- (d) Hydrogen and oxygen only

**Question 34**

The oxidation reaction among the following is:

[1]

- (a)  $\text{Fe}^{3+} + 3\text{e}^- \rightarrow \text{Fe}$
- (b)  $\text{Fe}^{2+} - \text{Ie}^- \rightarrow \text{Fe}^{3+}$
- (c)  $\text{Cl}_2 + 2\text{e}^- \rightarrow 2\text{Cl}^{1-}$
- (d)  $\text{Cu}^{2+} + 2\text{e}^- \rightarrow \text{Cu}$

**Question 35**

A student added excess of sodium hydroxide solution to each of the salt solution. An insoluble precipitate formed was observed in:

[1]

- (a) Calcium nitrate
- (b) Zinc nitrate
- (c) Lead nitrate
- (d) Sodium nitrate

**Question 36**

Which apparatus could be used to electroplate an iron nail with copper?

[1]

- (a)

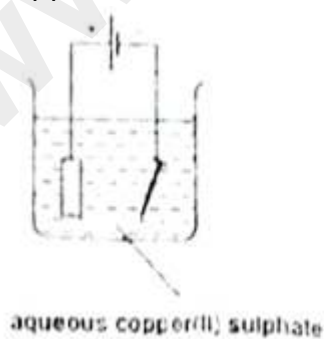

(b)

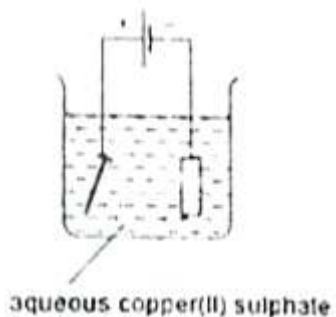

(c)

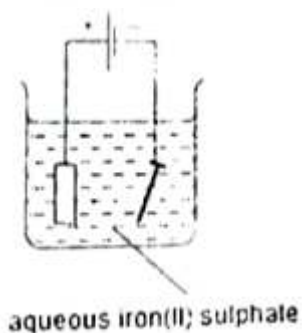

(d)

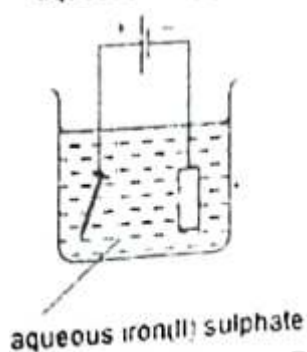

### Question 37

The table below shows the electronic arrangements of six atoms, A to F.

atom	A	B	C	D	E	F
electronic configuration	2, 5	2	2, 6	2, 8, 6	2, 8, 8	2, 8, 3

With respect to the table select the following:

(i) Two atoms from the same group of the periodic table: [1]

- (a) D and E
- (b) C and D
- (c) E and F
- (d) C and E

(ii) Two noble gases: [1]

- (a) A and B
- (b) E and F
- (c) B and E
- (d) D and E

(iii) The atom which is the most electronegative: [1]

- (a) A
- (b) B
- (c) C
- (d) F

(iv) The atom which has the highest ionization potential: [1]

- (a) A
- (b) B
- (c) E
- (d) F

www.ncertbooks.net

# Solution

---

**Solution 1-(b)** Ionization potential increases from left to right in a periodic table.

**Solution 2-(b)** Vapour Density =  $\frac{\text{Molar Mass}}{2} = \frac{58}{2} = 29$

**Solution 3-(c)** In electrolysis of molten lead bromide, brown vapours of bromine are obtained at anode.

**Solution 4-(b)** The tendency of an atom to attract shared pair of electrons to itself when forming a chemical bond is known as electronegativity.

**Solution 5-(c)** Solid NaCl does not contain electricity it does not contain electricity.

**Solution 6-(d)** Electronic configuration of A- 2, 6

Electronic configuration of B- 2, 8, 3

A required to gain 2 electrons to complete its octet so valency of A=-2

B required to donate 3 electrons to complete its octet so valency of B=+3

B is cation and A is anion so by using crisscross method in ionic compounds.

Chemical formula will be B<sub>2</sub>A<sub>3</sub>.

**Solution 7-(a)**

$$\% \text{ of H} = \frac{\text{Atomic mass of H}}{\text{Molar mass of NaOH}} = \frac{1}{23 + 16 + 1} \times 100 = \frac{100}{40} = 2.5\%$$

**Solution 8-(b)** A salt that is formed by incomplete neutralization of acid is acidic salt.

**Solution 9-(c)** Fe(OH)<sub>3</sub> precipitate formed after the addition of a small amount of sodium hydroxide solution to an aqueous solution of ferric chloride. Fe(OH)<sub>3</sub> is brown in colour.

**Solution 10-(a)** Alkaline earth metals are present in same group so they have same number of valence electrons.

**Solution 11-(d)** Carbon tetrachloride is covalent compound. So it neither dissociate nor ionise in water

**Solution 12-(a)** Two atoms of W will share 2-2 electrons to form covalent compound and become stable.

**Solution 13-(C)** After losing one electron, it will have electronic configuration of inert gas. So it will lose one electron and losing electron is oxidation process.

**Solution 14-(c)** Water molecule is having two lone pairs in molecule.

**Solution 15-(d)**

Molecular Formula = Empirical formula  $\times$  n

$$n = \frac{\text{Molecular mass}}{\text{Empirical formula mass}}$$

$$n = \frac{30}{10} = 3$$

Molecular formula =  $3 \times (\text{PQ}_2) = \text{P}_3\text{Q}_6$

**Solution 16-(c)**  $\text{H}_3\text{PO}_4$  is tribasic acid because it can donate 3  $\text{H}^+$  ions.

**Solution 17-(C)** Cupric ion preferentially discharged at the cathode due to its high mobility.

**Solution 18-(a)**  $\text{OH}^-$  ions will readily discharge at the anode during the electrolysis of acidulated water.

**Solution 19-(b)**

$$\begin{aligned} \text{Molar mass} &= \text{Vapour density} \times 2 \\ &= 13 \times 2 = 26 \end{aligned}$$

Molar mass of  $\text{C}_2\text{H}_2$  is 26.

**Solution 20-(d)** Aqueous solution of Cupric chloride forms a deep blue solution on addition of excess ammonium hydroxide

**Solution 21-(d)** Electricity is conducted in an acid solution by ions

**Solution 22-(a)** Metals have low ionization potential.

**Solution 23-(c)** Following structure is following octet and duplet rule.

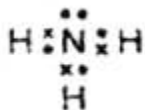

**Solution 24-(c)** When acid reacts with base, Salt and water is formed.

**Solution 25-(b)**

In the circuit below, the lamp lights up than X should be an Ionic compound.

**Solution 26-(b)** Ammonium ion is non-metallic.

**Solution 27-(c)** Bonding present in non-metal and non-metal is covalent.

**Solution 28-(a)** The non-metallic properties of elements from left to right in a Periodic Table increases.

**Solution 29-(c)** Acetic acid contains both ions and solution because it is a weak electrolyte.

**Solution 30-(b)** Metallic oxides are alkaline in nature.

**Solution 31-(a)**  $\text{pH}=2$ , that means solution is strong acid.

**Solution 32-(a)** Aluminium hydroxide can donate 3 OH ions, acidity is 3.

**Solution 33-(c)** Hydracids are those acids which contain Hydrogen and a non-metal other than oxygen.

**Solution 34-(b)** Loss of electrons is oxidation.

**Solution 35-(a)** An insoluble precipitate formed was observed in Calcium nitrate because it forms  $\text{Ca}(\text{OH})_2$ .

**Solution 36-(a)** First apparatus is having correct combination of anode-cathode with battery.

**Solution 37**

- (i) (b) Elements which have same number of outermost electrons are present in same group.
- (ii) (c) Element which have complete duplet or octet are inert gases.
- (iii) (c) Valency of C is -2. (It can accept 2 electrons to complete its octet).
- (iv) (b) B is He which is inert gas so it will have highest ionization potential.